

IBM TotalStorage FAStT EXP100  
Storage Expansion Unit



# Installation and User's Guide



IBM TotalStorage FAStT EXP100  
Storage Expansion Unit



# Installation and User's Guide

**Note:**

Before using this information and the product it supports, be sure to read the general information in "Notices" on page 85.

**First Edition (November 2003)**

**© Copyright International Business Machines Corporation 2003. All rights reserved.**

US Government Users Restricted Rights – Use, duplication or disclosure restricted by GSA ADP Schedule Contract with IBM Corp.

---

## Safety

The caution and danger statements that this document contains can be referenced in the multilingual *IBM Safety Information* document that is provided with your IBM TotalStorage FASTT EXP100 Storage Expansion Unit. Each caution and danger statement is numbered for easy reference to the corresponding statements in the translated document.

- **Danger:** These statements indicate situations that can be potentially lethal or extremely hazardous to you. A danger statement is placed just before the description of a potentially lethal or extremely hazardous procedure, step, or situation.
- **Caution:** These statements indicate situations that can be potentially hazardous to you. A caution statement is placed just before the description of a potentially hazardous procedure step or situation.
- **Attention:** These notices indicate possible damage to programs, devices, or data. An attention notice is placed just before the instruction or situation in which damage could occur.

Before installing this product, read the following danger and caution notices.

Statement 1:



**DANGER**

Electrical current from power, telephone, and communication cables is hazardous.

**To avoid a shock hazard:**

- Do not connect or disconnect any cables or perform installation, maintenance, or reconfiguration of this product during an electrical storm.
- Connect all power cords to a properly wired and grounded electrical outlet.
- Connect to properly wired outlets any equipment that will be attached to this product.
- When possible, use one hand only to connect or disconnect signal cables.
- Never turn on any equipment when there is evidence of fire, water, or structural damage.
- Disconnect the attached power cords, telecommunications systems, networks, and modems before you open the device covers, unless instructed otherwise in the installation and configuration procedures.
- Connect and disconnect cables as described in the following table when installing, moving, or opening covers on this product or attached devices.

<b>To Connect:</b>	<b>To Disconnect:</b>
<ol style="list-style-type: none"><li>1. Turn everything OFF.</li><li>2. First, attach all cables to devices.</li><li>3. Attach signal cables to connectors.</li><li>4. Attach power cords to outlet.</li><li>5. Turn device ON.</li></ol>	<ol style="list-style-type: none"><li>1. Turn everything OFF.</li><li>2. First, remove power cords from outlet.</li><li>3. Remove signal cables from connectors.</li><li>4. Remove all cables from devices.</li></ol>

**Statement 3:**



**CAUTION:**

When laser products (such as CD-ROMs, DVD drives, fiber optic devices, or transmitters) are installed, note the following:

- Do not remove the covers. Removing the covers of the laser product could result in exposure to hazardous laser radiation. There are no serviceable parts inside the device.
- Use of controls or adjustments or performance of procedures other than those specified herein might result in hazardous radiation exposure.



**DANGER**

Some laser products contain an embedded Class 3A or Class 3B laser diode. Note the following.

Laser radiation when open. Do not stare into the beam, do not view directly with optical instruments, and avoid direct exposure to the beam.



**Class 1 Laser statement**

**Class 1 Laser Product**  
**Laser Klasse 1**  
**Laser Klasse 1**  
**Luokan 1 Laserlaitte**  
**Appareil À Laser de Classe 1**

IEC 825-11993 CENELEC EN 60 825

**Statement 4:**



		
≥ 18 kg (39.7 lb)	≥ 32 kg (70.5 lb)	≥ 55 kg (121.2 lb)

**CAUTION:**

Use safe practices when lifting.

**Statement 5:**



**CAUTION:**

The power control button on the device and the power switch on the power supply do not turn off the electrical current supplied to the device. The device also might have more than one power cord. To remove all electrical current from the device, ensure that all power cords are disconnected from the power source.

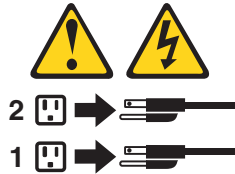



**Statement 8:**



**CAUTION:**

Never remove the cover on a power supply or any part that has the following label attached.



Hazardous voltage, current, and energy levels are present inside any component that has this label attached. There are no serviceable parts inside these components. If you suspect a problem with one of these parts, contact a service technician.



---

# Contents

<b>Safety</b> . . . . .	iii
<b>Figures</b> . . . . .	xiii
<b>Tables</b> . . . . .	xv
<b>About this document</b> . . . . .	xvii
Who should read this document . . . . .	xvii
How this document is organized . . . . .	xvii
FASTt installation process overview . . . . .	xviii
FASTt documentation . . . . .	xviii
FASTt600 Fibre Channel Storage Server library . . . . .	xix
FASTt900 Fibre Channel Storage Server library . . . . .	xix
FASTt EXP100 Expansion Unit library . . . . .	xx
FASTt Storage Manager Version 8.4 library . . . . .	xx
FASTt-related documents . . . . .	xxii
Getting information, help, and service . . . . .	xxii
Before you call . . . . .	xxii
Using the documentation . . . . .	xxiii
Web sites . . . . .	xxiii
Software service and support . . . . .	xxiii
Hardware service and support . . . . .	xxiv
Fire suppression systems . . . . .	xxiv
How to send your comments . . . . .	xxiv
<b>Chapter 1. Introduction</b> . . . . .	1
Overview . . . . .	1
Fibre Channel defined . . . . .	1
Serial ATA defined . . . . .	2
Inventory checklist . . . . .	2
FASTt EXP100 components . . . . .	2
FASTt EXP100 bays . . . . .	3
Hot-swap drive bays . . . . .	3
Fan, ESM, and power supply bays . . . . .	3
Front controls and indicators . . . . .	5
Rear controls, indicators, and connectors . . . . .	5
Power supply controls, indicators, and connectors . . . . .	5
Fan controls and indicators . . . . .	6
ESMs and user controls . . . . .	7
Storage management software and hardware compatibility . . . . .	9
FASTt EXP100 operating environment . . . . .	10
FASTt EXP100 specifications . . . . .	11
Heat output, airflow, and cooling . . . . .	12
<b>Chapter 2. Installing the FASTt EXP100</b> . . . . .	15
Handling static-sensitive devices . . . . .	16
Preparing for installation . . . . .	16
Preparing the site . . . . .	17
Preparing the rack . . . . .	17
Installing the FASTt EXP100 . . . . .	18
Rack mounting template . . . . .	18
Installing the support rails . . . . .	20
Removing the CRUs . . . . .	22

Removing an ESM . . . . .	23
Removing a power supply . . . . .	24
Removing a fan . . . . .	24
Removing a hard disk drive . . . . .	25
Installing the FAStT EXP100 into a rack. . . . .	26
Replacing the FAStT EXP100 CRUs . . . . .	27
Replacing an ESM . . . . .	27
Replacing a power supply . . . . .	27
Replacing a fan. . . . .	28
Replacing a hard disk drive . . . . .	29
Setting the interface options . . . . .	29
Fibre-channel loop and ID settings. . . . .	30
Enclosure ID settings . . . . .	30
Expansion unit speed settings . . . . .	31
Cabling the FAStT EXP100 . . . . .	31
Installing SFP modules . . . . .	32
Removing SFP modules . . . . .	34
Handling fiber-optic cables . . . . .	35
Using LC-LC fibre-channel cables . . . . .	35
Connecting an LC-LC cable to an SFP module . . . . .	36
Removing an LC-LC fibre-channel cable . . . . .	37
Cabling the FAStT EXP100 to a FAStT600 and FAStT900 . . . . .	38
Cabling the FAStT EXP100 to a FAStT600 Storage Server. . . . .	38
Cabling the FAStT EXP100 to a FAStT900 Fibre Channel Storage Server . . . . .	39
FAStT EXP100 loop redundancy . . . . .	40
Adding the FAStT EXP100 to a loop . . . . .	42
Cabling the power supply . . . . .	43
Turning the FAStT EXP100 on and off . . . . .	43
Turning on the FAStT EXP100 . . . . .	43
Turning off the FAStT EXP100 . . . . .	44
Performing an emergency shutdown . . . . .	45
Restoring power after an emergency . . . . .	46
<b>Chapter 3. Installing and replacing devices . . . . .</b>	<b>47</b>
Working with hot-swap hard disk drives . . . . .	47
Installing hot-swap hard disk drives . . . . .	48
Replacing hot-swap hard disk drives . . . . .	49
Replacing multiple drives . . . . .	50
Replacing all drives at the same time . . . . .	51
Replacing the drives one at a time. . . . .	53
Working with hot-swap power supplies . . . . .	54
Removing the failed hot-swap power supply . . . . .	55
Replacing the failed hot-swap power supply . . . . .	55
Replacing a failed hot-swap ESM . . . . .	57
Replacing a failed hot-swap cooling fan . . . . .	58
<b>Chapter 4. Solving problems . . . . .</b>	<b>61</b>
<b>Appendix A. Upgrading the FAStT controller firmware . . . . .</b>	<b>65</b>
<b>Appendix B. ESM failover architecture . . . . .</b>	<b>71</b>
Understanding ESM failover architecture . . . . .	71
ESM failover configuration guidelines. . . . .	73
<b>Appendix C. Records . . . . .</b>	<b>77</b>
Identification numbers . . . . .	77

Installed device records. . . . .	77
<b>Appendix D. Rack mounting template . . . . .</b>	<b>79</b>
<b>Appendix E. Power cords . . . . .</b>	<b>83</b>
<b>Notices . . . . .</b>	<b>85</b>
Trademarks . . . . .	85
Important notes. . . . .	86
Electronic emission notices . . . . .	86
Federal Communications Commission (FCC) statement . . . . .	86
Chinese class A compliance statement . . . . .	87
Industry Canada Class A emission compliance statement . . . . .	87
Australia and New Zealand Class A statement . . . . .	87
United Kingdom telecommunications safety requirement. . . . .	87
European Union EMC Directive conformance statement. . . . .	87
Taiwan Class A warning statement. . . . .	88
Japanese Voluntary Control Council for Interference (VCCI) statement . . . . .	88
<b>Glossary . . . . .</b>	<b>89</b>
<b>Index . . . . .</b>	<b>97</b>



# Figures

1. Installation process flow by current publications . . . . .	xviii
2. FASTt EXP100 hot-swap drive bays . . . . .	3
3. Hot-swap fan, ESM, and power supply bays . . . . .	4
4. Front controls and indicators . . . . .	5
5. Power supply controls, indicators, and connectors . . . . .	6
6. Fan controls and indicators . . . . .	7
7. ESMs and user controls. . . . .	8
8. Example of cold aisle/hot aisle rack configuration . . . . .	13
9. Front rack mounting template . . . . .	19
10. Rear rack mounting template . . . . .	20
11. Alignment pins with and without spacers . . . . .	21
12. Installing the support rails . . . . .	22
13. Removing an ESM . . . . .	24
14. Removing a power supply . . . . .	24
15. Removing a fan unit. . . . .	25
16. Removing a drive CRU . . . . .	25
17. Installing the FASTt EXP100 . . . . .	26
18. Replacing an ESM . . . . .	27
19. Replacing a power supply . . . . .	28
20. Replacing a fan . . . . .	29
21. Enclosure ID switches . . . . .	30
22. Enclosure ID settings . . . . .	31
23. SFP module and protective cap . . . . .	33
24. Installing an SFP module into the host port . . . . .	34
25. Unlocking the SFP module latch - plastic variety . . . . .	34
26. Unlocking the SFP module latch - wire variety . . . . .	35
27. LC-LC fibre-channel cable . . . . .	36
28. Removing fiber-optic cable protective caps . . . . .	37
29. Inserting an LC-LC fibre-channel cable into an SFP module . . . . .	37
30. LC-LC fibre-channel cable lever and latches. . . . .	38
31. Removing the LC-LC fibre-channel cable . . . . .	38
32. Connecting cables to the installed SFP. . . . .	39
33. Installing an SFP module and connecting an LC-LC cable to the FASTt EXP100 . . . . .	39
34. Installing an SFP module and LC-LC cable in a FASTt900 . . . . .	40
35. Installing an SFP module and connecting an LC-LC cable to the FASTt EXP100 . . . . .	40
36. FASTt EXP100 redundant loop configuration . . . . .	41
37. Cabling the FASTt EXP100 to two redundant loops . . . . .	42
38. Hot-swap hard disk drive LEDs . . . . .	48
39. Drive CRU handle . . . . .	49
40. Moving the power supply lever and replacing the failed hot-swap power supply . . . . .	56
41. Connecting the power supply . . . . .	57
42. Removing the failed ESM. . . . .	58
43. Replacing a hot-swap cooling fan. . . . .	59
44. FASTt EXP100 ESM and drive paths . . . . .	71
45. The right ESM and controller firmware recover from a loss of connectivity to the input port of the left ESM . . . . .	72
46. Loss of access to drives in odd-numbered drive slots because the left ESM itself failed . . . . .	73
47. Orthogonally striped RAID arrays – Option 1 . . . . .	74
48. Orthogonally striped RAID arrays – Option 2 . . . . .	75
49. Using up two drives in a FASTt EXP100 in the RAID array . . . . .	76
50. Front rack mounting template . . . . .	80
51. Rear rack mounting template . . . . .	81





---

## Tables

1. TotalStorage FAStT600 Fibre Channel Storage Server document titles by user tasks . . . . .	xix
2. TotalStorage FAStT900 Fibre Channel Storage Server document titles by user tasks . . . . .	xix
3. FAStT EXP100 Expansion Unit document titles by user tasks . . . . .	xx
4. TotalStorage FAStT Storage Manager Version 8.4 titles by user tasks . . . . .	xxi
5. TotalStorage FAStT related document titles by user tasks . . . . .	xxii
6. FAStT EXP100 hardware and software compatibility . . . . .	10
7. IBM TotalStorage FAStT EXP100 Storage Expansion Unit specifications . . . . .	11
8. Alignment pin requirements for different rack flange hole types . . . . .	21
9. Drive LED activity . . . . .	47
10. Solving problems . . . . .	61
11. Hard disk drive record . . . . .	77



---

## About this document

This document provides instructions for installing and customizing the configuration of your IBM® TotalStorage® FAStT EXP100 Storage Expansion Unit. It also provides maintenance procedures and troubleshooting information.

---

## Who should read this document

This document is intended for system operators and service technicians who have extensive knowledge of Fibre Channel and network technology.

---

## How this document is organized

Chapter 1, "Introduction," on page 1 describes the IBM TotalStorage FAStT EXP100 Storage Expansion Unit. This chapter includes an inventory checklist and an overview of the storage expansion unit features, operating specifications, and components.

Chapter 2, "Installing the FAStT EXP100," on page 15 contains instructions for the following tasks:

- Install the expansion unit in a standard rack cabinet
- Set the interface options
- Cable the expansion unit
- Route the power cord
- Power the expansion unit on or off during either normal or emergency situations

Chapter 3, "Installing and replacing devices," on page 47 contains step-by-step instructions for how to install or remove customer replaceable units (CRUs), such as hard disk drives, power supplies, environmental services monitors (ESMs), and fan units.

Chapter 4, "Solving problems," on page 61 contains problems, symptoms, and error messages that are specific to your expansion unit.

Appendix A, "Upgrading the FAStT controller firmware," on page 65 contains instructions for how to upgrade the FAStT controller firmware to enable support of the FAStT EXP100 expansion unit.

Appendix B, "ESM failover architecture," on page 71 contains guidelines for array configurations that offer maximum protection of data access in the event of ESM failure in the initial release of the FAStT EXP100 expansion unit.

Appendix C, "Records," on page 77 provides a table that you can use to record and update important information about your FAStT EXP100, including serial number and device records. Whenever you add options to your FAStT EXP100, be sure to update the information in this table.

Appendix D, "Rack mounting template," on page 79 provides the rack mounting templates for installation of the FAStT EXP100. If you want to tear out the templates from the document for use during installation, use these copies of the templates.

Appendix E, "Power cords," on page 83 lists power cord information for the FAStT EXP100.

# FASTt installation process overview

The following flow chart gives an overview of the FASTt hardware and the FASTt Storage Manager software installation process. Lined arrows in the flow chart indicate consecutive steps in the hardware and software installation process. Labeled arrows indicate which current documents provide detailed information about those steps.

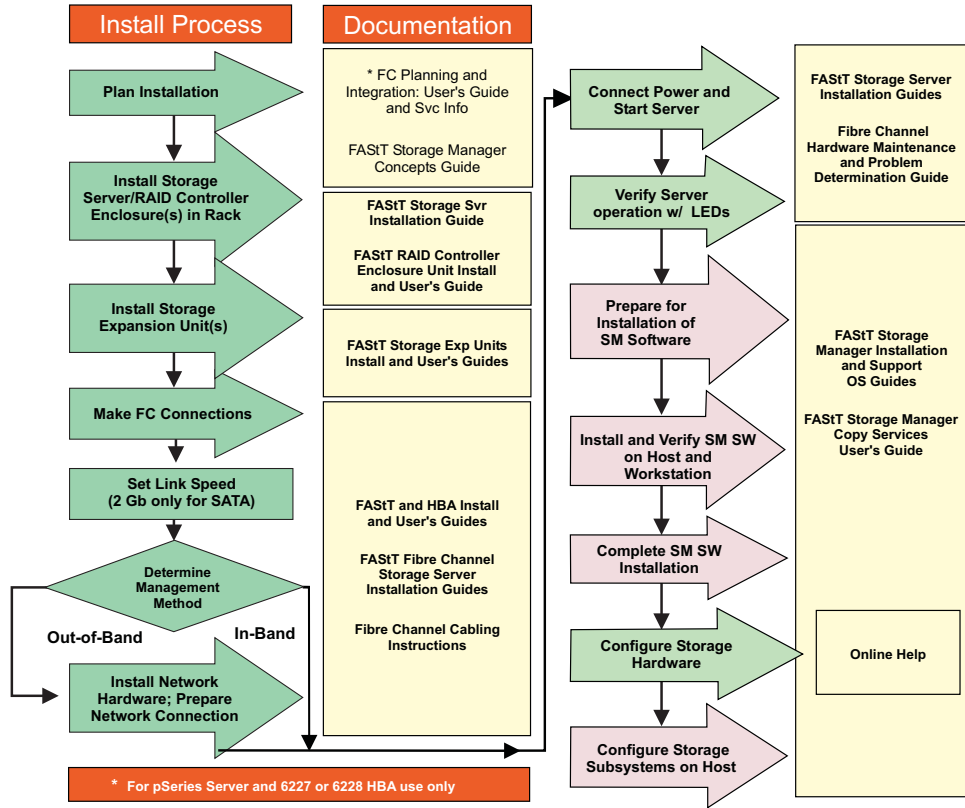

Figure 1. Installation process flow by current publications

## FASTt documentation

The following tables present an overview of the FASTt Storage Manager, FASTt600 Fibre Channel Storage Server, FASTt900 Fibre Channel Storage Server, and FASTt EXP100 Storage Expansion Unit product libraries, as well as other related documents. Each table lists documents that are included in the libraries and what common tasks they address. Click on active links in the tables to access those documents currently available on the Internet. You can access documentation for the other FASTt products at the following Web site:

[ssddom02.storage.ibm.com/techsup/webnav.nsf/support/fastt](http://ssddom02.storage.ibm.com/techsup/webnav.nsf/support/fastt)

## FAStT600 Fibre Channel Storage Server library

Table 1 associates each document in the FAStT600 Fibre Channel Storage Server library with its related common user tasks.

Table 1. TotalStorage FAStT600 Fibre Channel Storage Server document titles by user tasks

Title	User Tasks					
	Planning	Hardware Installation	Software Installation	Configuration	Operation and Administration	Diagnosis and Maintenance
IBM TotalStorage FAStT600 Fibre Channel Storage Server Installation and User's Guide, GC26-7531	✓	✓		✓		
IBM TotalStorage FAStT Fibre Channel Hardware Maintenance Manual and Problem Determination Guide, GC26-7528						✓
IBM TotalStorage FAStT FC2-133 Dual Port Host Bus Adapter Installation and User's Guide, GC26-7532		✓			✓	
IBM TotalStorage FAStT600 Rack Mounting Instructions, 24P8125	✓	✓				
IBM TotalStorage FAStT600 Cabling Instructions, 24P8126	✓	✓				

## FAStT900 Fibre Channel Storage Server library

Table 2 associates each document in the FAStT900 Fibre Channel Storage Server library with its related common user tasks.

Table 2. TotalStorage FAStT900 Fibre Channel Storage Server document titles by user tasks

Title	User Tasks					
	Planning	Hardware Installation	Software Installation	Configuration	Operation and Administration	Diagnosis and Maintenance
IBM TotalStorage FAStT900 Storage Server Installation and Support Guide, GC26-7530	✓	✓		✓		

Table 2. TotalStorage FAStT900 Fibre Channel Storage Server document titles by user tasks (continued)

Title	User Tasks					
	Planning	Hardware Installation	Software Installation	Configuration	Operation and Administration	Diagnosis and Maintenance
IBM TotalStorage FAStT900 Storage Server Fibre Channel Cabling Instructions, 24P8135	✓	✓				
IBM TotalStorage FAStT900 Storage Server User's Guide, GC26-7534				✓	✓	✓
IBM TotalStorage FAStT900 Rack Mounting Instructions, 19K0900	✓	✓				

## FAStT EXP100 Expansion Unit library

Table 3 associates each document in the FAStT EXP100 Expansion Unit library with its related common user tasks.

Table 3. FAStT EXP100 Expansion Unit document titles by user tasks

Title	User Tasks					
	Planning	Hardware Installation	Software Installation	Configuration	Operation and Administration	Diagnosis and Maintenance
IBM TotalStorage FAStT EXP100 Storage Expansion Unit Installation and User's Guide GC26-7601	✓	✓		✓		
IBM TotalStorage FAStT Fibre Channel Hardware Maintenance Manual and Problem Determination Guide, GC26-7528						✓
IBM TotalStorage FAStT EXP100 Storage Expansion Unit Release Notes, GC26-7619	✓			✓	✓	

## FAStT Storage Manager Version 8.4 library

Table 4 on page xxi associates each document in the FAStT Storage Manager library with its related common user tasks.

Table 4. TotalStorage FAST Storage Manager Version 8.4 titles by user tasks

Title	User Tasks					
	Planning	Hardware Installation	Software Installation	Configuration	Operation and Administration	Diagnosis and Maintenance
IBM TotalStorage FAST600 Turbo Option and Storage Manager 8.4 Library Guide and Common Index, GC26-7600	✓	✓	✓	✓	✓	✓
IBM TotalStorage FAST Storage Manager 8.4x Installation and Support Guide for Intel-based Operating System Environments, GC26-7621	✓		✓	✓		
IBM TotalStorage FAST Storage Manager 8.4x Installation and Support Guide for AIX®, UNIX, and Solaris, GC26-7622	✓		✓	✓		
IBM TotalStorage FAST Storage Manager Copy Services User's Guide, GC26-7561	✓		✓	✓	✓	
IBM FAST Storage Manager Script Commands (see product CD)				✓		
IBM TotalStorage FAST Storage Manager Concepts Guide, GC26-7560	✓	✓	✓	✓	✓	✓

## FAStT-related documents

Table 5 associates each of the following documents related to FAStT operations with its related common user tasks.

Table 5. TotalStorage FAStT related document titles by user tasks

Title	User Tasks					
	Planning	Hardware Installation	Software Installation	Configuration	Operation and Administration	Diagnosis and Maintenance
IBM Safety Information, P48P9741					✓	
IBM Netfinity® Fibre Channel Cabling Instructions, 19K0906		✓				
IBM Fibre Channel SAN Configuration Setup Guide, 25P2509	✓		✓	✓	✓	

## Getting information, help, and service

If you need help, service, or technical assistance or just want more information about IBM products, you will find a wide variety of sources available from IBM to assist you. This section contains information about where to go for additional information about IBM and IBM products, what to do if you experience a problem with your IBM @server xSeries™ or IntelliStation® system, and whom to call for service, if it is necessary.

### Before you call

Before you call, make sure that you have taken these steps to try to solve the problem yourself:

- Check all cables to make sure that they are connected.
- Check the power switches to make sure that the system is turned on.
- Use the troubleshooting information in your system documentation and use the diagnostic tools that come with your system.
- Check for technical information, hints, tips, and new device drivers at the following Web site:  
[www.ibm.com/storage/techsup.htm](http://www.ibm.com/storage/techsup.htm)
- Use an IBM discussion forum on the IBM Web site to ask questions.

You can solve many problems without outside assistance by following the troubleshooting procedures that IBM provides in the online help or in the documents that are provided with your system and software. The information that comes with your system also describes the diagnostic tests that you can perform. Most xSeries and IntelliStation systems, operating systems, and programs come with information that contains troubleshooting procedures and explanations of error messages and error codes. If you suspect a software problem, see the information for the operating system or program.



## Using the documentation

Information about the xSeries or IntelliStation system and preinstalled software, if any, is available in the documents that come with your system. This includes printed documents, online documents, readme files, and help files. See the troubleshooting information in your system documentation for instructions on how to use the diagnostic programs. The troubleshooting information or the diagnostic programs might tell you that you need additional or updated device drivers or other software.

## Web sites

IBM maintains pages on the World Wide Web where you can get the latest technical information and download device drivers and updates.

- For FASTT information, go to the following Web site:

[www.ibm.com/storage/techsup.htm](http://www.ibm.com/storage/techsup.htm)

The support page has many sources of information and ways for you to solve problems, including:

- Diagnosing problems using the IBM Online Assistant
  - Downloading the latest device drivers and updates for your products
  - Viewing frequently asked questions (FAQ)
  - Viewing hints and tips to help you solve problems
  - Participating in IBM discussion forums
  - Setting up e-mail notification of technical updates about your products
- You can order publications through the IBM Publications Ordering System at the following web site:  
[www.elink.ibm.com/public/applications/publications/cgibin/pbi.cgi/](http://www.elink.ibm.com/public/applications/publications/cgibin/pbi.cgi/)
  - For the latest information about IBM xSeries products, services, and support, go to the following Web site:  
[www.ibm.com/eserver/xseries/](http://www.ibm.com/eserver/xseries/)
  - For the latest information about IBM pSeries products, services, and support, go to the following Web site:  
[www.ibm.com/eserver/pseries/](http://www.ibm.com/eserver/pseries/)
  - For the latest information about the IBM IntelliStation information, go to the following Web site:  
[www.ibm.com/pc/intellistation/](http://www.ibm.com/pc/intellistation/)
  - For the latest information about operating system and HBA support, clustering support, SAN fabric support, and Storage Manager feature support, see the TotalStorage FASTT Interoperability Matrix at the following Web site:  
[www.storage.ibm.com/disk/fastt/supserver.htm](http://www.storage.ibm.com/disk/fastt/supserver.htm)

## Software service and support

Through IBM Support Line, for a fee you can get telephone assistance with usage, configuration, and software problems with xSeries servers, IntelliStation workstations, and appliances. For information about which products are supported by Support Line in your country or region, go to the following Web site:

[www.ibm.com/services/sl/products/](http://www.ibm.com/services/sl/products/)

For more information about the IBM Support Line and other IBM services, go to the following Web sites:

- [www.ibm.com/services/](http://www.ibm.com/services/)

- [www.ibm.com/planetwide/](http://www.ibm.com/planetwide/)

## Hardware service and support

You can receive hardware service through IBM Integrated Technology Services or through your IBM reseller, if your reseller is authorized by IBM to provide warranty service. Go to the following Web site for support telephone numbers:

[www.ibm.com/planetwide/](http://www.ibm.com/planetwide/)

In the U.S. and Canada, hardware service and support is available 24 hours a day, 7 days a week. In the U.K., these services are available Monday through Friday, from 9 a.m. to 6 p.m.

## Fire suppression systems

A fire suppression system is the responsibility of the customer. The customer's own insurance underwriter, local fire marshal, or a local building inspector, or both, should be consulted in selecting a fire suppression system that provides the correct level of coverage and protection. IBM designs and manufactures equipment to internal and external standards that require certain environments for reliable operation. Because IBM does not test any equipment for compatibility with fire suppression systems, IBM does not make compatibility claims of any kind nor does IBM provide recommendations on fire suppression systems.

Table 7 on page 11 lists the environmental specifications for the EXP100.

---

## How to send your comments

Your feedback is important to help us provide the highest quality information. If you have any comments about this document, you can submit them in one of the following ways:

- E-mail

Submit your comments electronically to:

[starpubs@us.ibm.com](mailto:starpubs@us.ibm.com)

Be sure to include the name and order number of the document and, if applicable, the specific location of the text that you are commenting on, such as a page number or table number.

- Mail or fax

Fill out the Readers' Comments form (RCF) at the back of this document and return it by mail or fax (1-408-256-0488) or give it to an IBM representative. If the RCF has been removed, you can address your comments to:

International Business Machines Corporation  
RCF Processing Department  
Dept. FTFA/Bldg. 050-1  
5600 Cottle Road  
San Jose, CA 95193-0001  
U.S.A

When you send information to IBM, you grant IBM a nonexclusive right to use or distribute the information in any way it believes appropriate without incurring any obligation to you.

---

## Chapter 1. Introduction

This chapter describes the operating specifications, features, and components for the IBM TotalStorage Fibre Array Storage Technology (FAST) EXP100 Storage Expansion Unit (hereafter referred to as FAST EXP100 or expansion unit). This chapter also includes a list of hardware that comes with the expansion unit.

**Attention:** If you have not already done so, read the *IBM TotalStorage FAST EXP100 Storage Expansion Unit Release Notes* document for important information about the installation and operation of the FAST EXP100 with FAST storage servers.

---

### Overview

Designed for data archival, data reference, and near-line storage applications, the IBM TotalStorage FAST EXP100 Storage Expansion Unit enables the attachment of Serial Advanced Technology Attachment (SATA) disk drives for FAST600 and FAST900 Storage Servers. The FAST EXP100 is a rack-mountable enclosure that supports up to fourteen 1.5 Gbps 250 GB SATA disk drive modules, offering up to 3.5 terabytes (TB) of capacity per enclosure. Coupled with FAST600 and FAST900 Storage Servers, you can configure RAID-protected storage solutions of up to 56 TB, providing economical and scalable storage for your rapidly growing application needs for limited access, data reference storage capacity. The FAST EXP100 utilizes the latest SATA disk drive technology and is designed with redundant 2 Gbps Fibre Channel connections to the FAST storage server, offering reliability and performance.

The FAST EXP100 supports redundant, dual-loop configurations with FAST600 and FAST900 Storage Servers and other FAST EXP100 units. External cables and small form-factor pluggable (SFP) modules connect the controller to the expansion unit. FAST EXP100s attached to supported FAST storage servers can be used with storage area networks to satisfy the needs of various fixed content, data reference applications that require large amounts of storage capacity but do not have the high utilization and access characteristics satisfied by Fibre Channel disk drive storage. The expansion unit provides continuous, reliable service, using hot-swap technology for easy replacement without shutting down the system. Up to eight FAST EXP100 units can be connected together in a fibre-channel loop, providing connections to a maximum of 112 hard drives.

**Note:** SATA hard drive CRUs cannot be interchanged with the fibre-channel hard drive CRUs that are supported in other FAST storage products.

### Fibre Channel defined

Fibre Channel technology is outlined in the *SCSI-3 Fibre Channel Protocol* (SCSI-FCP) standard. Fibre Channel is a high-speed data transport technology that is used for mass storage and networking.

Using a fibre-channel arbitrated loop (FC-AL), more than 100 fibre-channel devices<sup>1</sup> can be supported, compared to 15 small computer system interface (SCSI) devices. The connection from the FAST storage server to the FAST EXP100 is a 2 Gb

---

1. For the FAST storage server, each drive is considered to be a device in a fibre-channel loop, even though the FAST EXP100 drive interface is SATA (not Fibre Channel). The ESM and the interposer convert SATA interface protocol to Fibre Channel protocol.

fibre-channel device that supports data transfer rates up to 200 MBps half-duplex and 400 MBps full-duplex on optical interfaces.

## Serial ATA defined

The Serial Advanced Technology Attachment (SATA) interface offers increased data rate performance over Parallel Advanced Technology Attachment (ATA), while maintaining the benefits of ATA. SATA is designed to overcome the performance barriers that have been forecasted for current parallel technologies while maintaining the cost-efficiency of Parallel ATA. SATA specifications allow for thinner, more flexible cables, and lower pin counts. It also enables easier, more flexible cable routing management and the use of smaller connectors than is possible with the existing Parallel ATA technology.

The Serial ATA Working Group introduced the first SATA specification, Serial ATA 1.0, in 2001 (<http://www.serialata.org>).

---

## Inventory checklist

The FAStT EXP100 ships with the following items:

- Power cables (2 jumper line cords; the 10U also includes 2 9 ft U.S. line cords)
- One rack-mounting hardware kit, including:
  - Two rails (right and left assembly)
  - Eight M6 black hex-head slotted screws
- 14 blank trays (your expansion unit might come with up to 14 hard disk drives)
- Box ID labels (used to label the enclosure IDs on the front of the EXP100)
- *FAStT Storage Manager V8.41 Support for FAStT EXP100 SATA Storage Expansion Unit CD*

A rack mounting template and instructions for installing the support rails and the expansion unit are provided in this book in Chapter 2, “Installing the FAStT EXP100,” on page 15.

To connect your FAStT EXP100 to other devices, use the following options:

- IBM SFP module
- IBM LC-LC fibre-channel cable

**Note:** You must order these options separately.

---

## FAStT EXP100 components

The FAStT EXP100 has the following removable components. These components, called customer replaceable units (CRUs), are accessible from the front or back of the FAStT EXP100.

- Up to fourteen FAStT 1.5 Gbps SATA hard disk drives
- Two environmental services monitors (ESMs)
- Two power supplies
- Two fans

---

## FASTT EXP100 bays

This section shows the location of FASTT EXP100 hot-swap CRU bays and describes the function of each CRU. The hot-swap features of the FASTT EXP100 enable you to remove and replace FASTT 1.5 Gbps SATA hard disk drives, power supplies, ESMs, and fan units without turning off the expansion unit. You can maintain the availability of your system while a hot-swap device is removed, installed, or replaced.

### Hot-swap drive bays

The hot-swap drive bays that are accessible from the front of your expansion unit are shown in Figure 2.

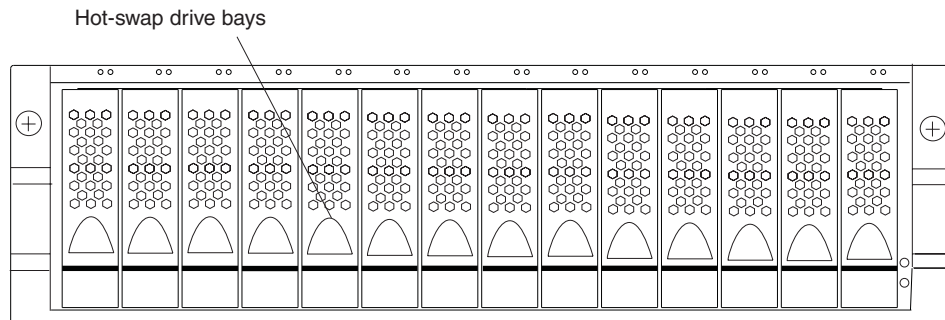

Figure 2. FASTT EXP100 hot-swap drive bays

The FASTT EXP100 supports up to 14 FASTT 1.5 Gbps SATA hard disk drives. These drives are preinstalled in drive trays. This drive and carrier assembly is called a drive CRU. The SATA drive CRU includes the drive tray, the SATA drive, and the hard disk drive (HDD) interposer card. You install the drive CRUs in the 14 drive bays on the front of the expansion unit. There are no serviceable parts in a drive CRU. If it fails, it must be replaced in its entirety (drive, interposer, bezel, and tray).

#### Attention:

1. Never hot-swap a drive CRU when its associated green Activity LED is flashing. Hot-swap a drive CRU only when its associated amber Fault LED lights and is not flashing or when the drive is inactive and its associated green Activity LED lights and is not flashing.
2. The SATA drive and its HDD card are digitally signed together at the factory. Do not swap drives and interposers between drive CRUs. Do not replace one SATA drive with another SATA drive. These actions will result in a drive CRU that cannot be recognized by the expansion unit ESM.

**Note:** If the hard disk drive you want to remove is not in a failed or bypass state, always use the Storage Manager client program either to place the drive in a failed state or to place the array that is associated with the drive (or drives) in an offline state before you remove the drive from the enclosure.

### Fan, ESM, and power supply bays

The locations of the FASTT EXP100 hot-swap fan bays, hot-swap ESM bays, and hot-swap power supply bays are shown in Figure 3 on page 4.

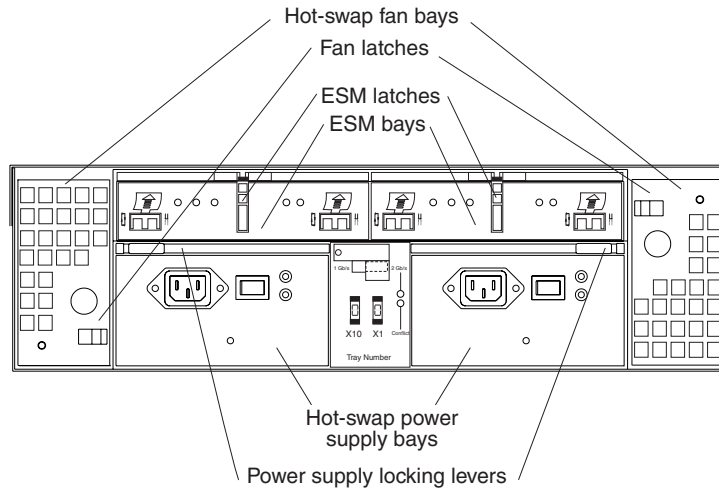

Figure 3. Hot-swap fan, ESM, and power supply bays

- **Hot-swap fan bays:** The FAST EXP100 has two interchangeable hot-swap and redundant fan units. These two fan units are located in the hot-swap fan bays. Each fan unit contains two fans. If one fan unit fails, the second fan unit continues to operate. You must install both fan units to maintain proper cooling within your expansion unit, even if one fan unit is not operational.

The fan CRUs have locking latches that secure them to the fan bays. You must unlock the latches before you can remove the fan from the expansion unit. When you replace a fan, you must align it properly for the side in which it is being replaced. See Figure 3.

- **ESM bays:** The FAST EXP100 has two hot-swappable ESMs. The ESMs are located in the ESM bays. The ESMs provide a 1.5 Gbps Serial ATA interface to the drives and monitor the overall status of the expansion unit. Each ESM has two SFP module connector fibre-channel ports that you use to connect your expansion unit to the FAST storage server, or to connect two or more FAST EXP100 units together. The ESMs provide redundancy when both of them are configured into redundant fibre-channel loops.

**Attention:** See Appendix B, “ESM failover architecture,” on page 71 for more information about ESM redundancy and failover configurations.

The ESMs have locking latches that secure them to the ESM bays. You must unlock the latches before you can remove the ESM from the expansion unit.

- **Hot-swap power supply bays:** The FAST EXP100 has two hot-swap and redundant power supplies. The power supplies are located in the hot-swap power supply bays. You must install both power supplies in your expansion unit, even if one power supply is not operational.

The power supplies have locking levers that secure them to the power supply bays. You must unlock the levers before you can remove the power supply from the expansion unit. The power supplies are interchangeable, but you must mount the lever on the interior corner of the power supply CRU (that is, when viewed from the back of the unit, the power supply CRU in the left power supply bay has the lever mounted on the right side, and the one in the right power supply bay has the lever mounted on the left side). See Figure 40 on page 56.

---

## Front controls and indicators

This section describes the primary controls on the front of the expansion unit. The locations of these primary controls are shown in Figure 4.

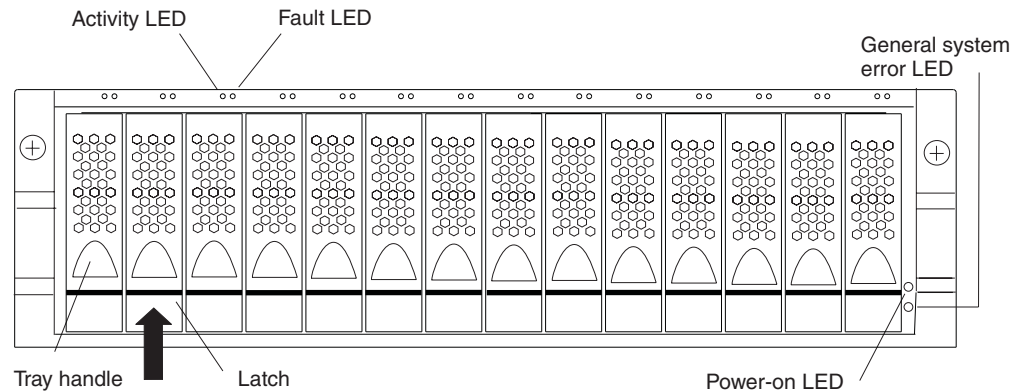

Figure 4. Front controls and indicators

The FAST EXP100 has blank trays in the unused drive bays. To begin installing new drives, you must first remove the blank trays and save them. Each of the 14 bays must always contain either a blank tray or a drive CRU. You can install up to 14 hot-swap drive CRUs in the expansion unit.

- **Activity LED:** Each drive CRU has an associated Activity LED on the FAST EXP100 chassis. A flashing green LED indicates drive activity. A solid green LED indicates that the drive is properly installed and powered on.
- **Fault LED:** Each drive CRU has an associated Fault LED on the FAST EXP100 chassis. A solid amber LED indicates a drive failure. A flashing amber LED indicates that a drive identify process is in progress.
- **General system error LED:** A solid amber LED indicates that the unit has a power supply, fan unit, or hard disk drive error.
- **Latch:** Use this multipurpose latch to release or lock the drive CRU in place.
- **Power-on LED:** A solid green LED indicates that the expansion unit has dc power.
- **Tray handle:** Use this multipurpose handle to insert and remove a drive CRU in the bay.

---

## Rear controls, indicators, and connectors

You access the two hot-swap power supply CRUs, the two hot-swap fan CRUs, and the two ESMs from the back of the expansion unit. These components contain several controls, indicators, and connectors.

### Power supply controls, indicators, and connectors

The FAST EXP100 has two 400-Watt hot-swappable, redundant power supplies. If one power supply fails, the remaining power supply can support all 14 disk drives running continuously. Each power supply has a Power LED and a Fault LED on the back of the FAST EXP100. The green Power LED indicates that the power supply is detecting ac power. The amber Fault LED lights if the power supply is unable to deliver dc power. Both power supplies must be installed to meet Electromagnetic Compatibility (EMC) and cooling requirements. Figure 5 on page 6 shows the power supply and the locations of the controls, indicators, and connectors.



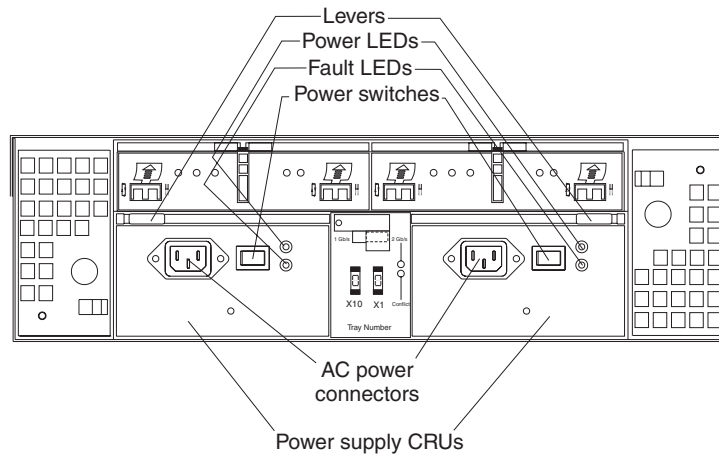

Figure 5. Power supply controls, indicators, and connectors

- **Hot-swap power supply CRUs:** The two hot-swap power supplies are located on the back of the FAST EXP100. You must install both power supply CRUs, even if one power supply is not working.
- **Levers:** Unlock these levers when you remove or install a power supply CRU.
- **Power LEDs:** These green Power LEDs light when the expansion unit is turned on and receiving ac power.
- **Fault LED:** The amber Fault LEDs light if a power supply failure occurs. The Fault LED for one power supply might also light if it is powered off while the other power supply is powered on.
- **Power switches:** Use these switches to turn the power supplies on and off. You must turn on both switches to use the redundant power supplies.
- **AC power connectors:** To provide ac power to the expansion unit, you must connect the power cables to the ac power connectors that are located on the back of the FAST EXP100.

## Fan controls and indicators

The FAST EXP100 has two hot-swappable and redundant fan units, as shown in Figure 6 on page 7. The fan units are located at the back of the expansion unit. One fan will continue to operate if the other fan fails. You can remove and replace the fan unit while the FAST EXP100 is powered on and accessing drives.

Each fan has a temperature sensor built into the air inlet. This sensor maintains fan speed to provide the necessary air flow. If the speed of one of the fans drops to a level that is too low or stops, the Fault LED located on the back of the fan unit lights, and the General system error LED on the front of the FAST EXP100 lights. For the locations of the LEDs on the front of the expansion unit, see Figure 4 on page 5. For the LEDs on the back of the expansion unit, see Figure 6 on page 7.

**Attention:** The fans in your expansion unit draw in fresh air and force out hot air. These fans are hot-swappable and redundant; however, when one fan fails, the fan unit must be replaced within 48 hours to maintain redundancy and optimum cooling. When you remove the failed unit, be sure to install the replacement fan unit within 10 minutes to prevent overheating.



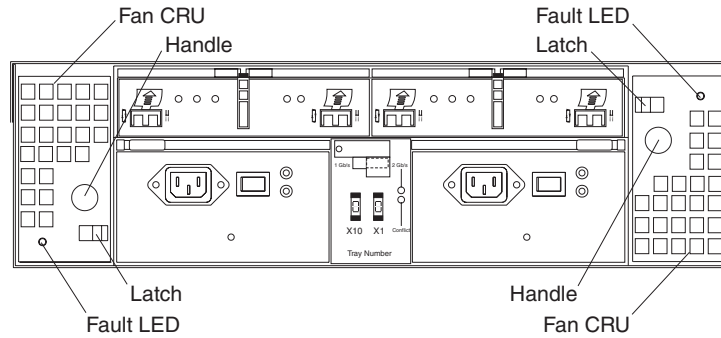

Figure 6. Fan controls and indicators

- **Fan CRUs:** The two fan CRUs are located at the back of the expansion unit. These fan units are hot-swappable and redundant.
- **Latches and handles:** Use the latches and handles to remove or install the fan CRUs.
- **Fault LED:** The amber fan Fault LED lights if a fan failure occurs.

## ESMs and user controls

The FAS*t*T EXP100 has two hot-swappable and redundant ESM units. The ESMs are located at the back of the expansion unit. One ESM will continue to operate if the other ESM fails. The ESMs contain the expansion unit control logic, interface ports, and LEDs. Each ESM has two SFP module ports that you use to connect the expansion unit to the controller. The FAS*t*T EXP100 ESMs and user controls are shown in Figure 7 on page 8.

**Attention:** Refer to the *FAS*t*T EXP100 Storage Expansion Unit Release Notes* and Appendix B, “ESM failover architecture,” on page 71 for a description of current ESM failover and redundancy support.

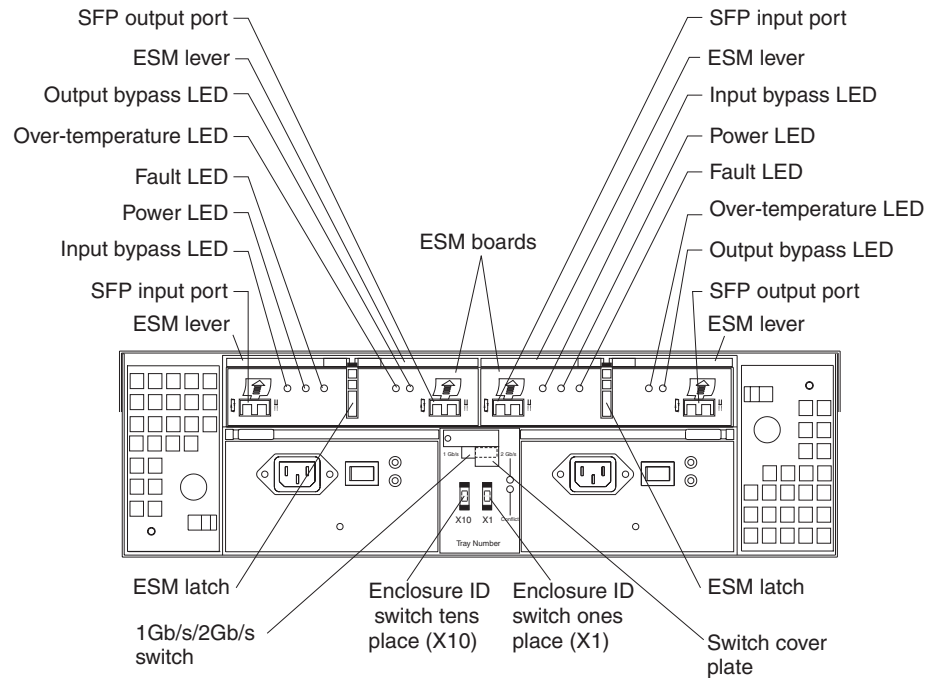

Figure 7. ESMs and user controls

- **SFP module input and output ports:** Each ESM has two SFP module connector ports that you use to connect the expansion unit to the FAST storage server, or to connect two or more FAST EXP100 expansion units together. Install an SFP module into the input and output ports. Use fibre-channel cables to connect the expansion unit to the FAST storage server or to additional expansion units.
- **ESM latch:** The ESM latch secures the ESM to the expansion unit.
- **ESM levers:** Unlock the ESM latch before you use the ESM levers to remove the ESM from the expansion unit. When you install the ESM into the bay, use the ESM levers to guide the unit into the ESM bay.
- **Fault LED:** The amber ESM Fault LED lights when an ESM failure occurs. The Fault LED also lights for approximately 15 seconds when you power on the expansion unit.
- **Input/output bypass LEDs:** These amber LEDs light when a faulty SFP module or fiber-optic cable is installed. Both ports on the ESM are bypassed when an ESM fault occurs and the ESM Fault LED and the Input and Output bypass LEDs light. This LED also lights if an SFP module is installed and is not connected to another device.
- **Power LED:** The green Power LED lights when there is power to the ESM.
- **Over-temperature LED:** The amber over-temperature LED lights if the expansion unit overheats.
- **Enclosure ID switches:** Two enclosure ID switches are located between the power supplies at the rear of the FAST EXP100. These switches identify the FAST EXP100 on a fibre-channel loop. You can use the push buttons to set the values 0 - 77.
- **1 Gbps, 2 Gbps switch:**  
The default switch setting is 2 Gbps. This is the *only* speed setting that is allowed for the FAST EXP100.

**Attention:** Do not remove the metal plate that covers the expansion unit speed setting. Do not adjust the expansion unit speed setting.

---

## Storage management software and hardware compatibility

**CAUTION:**

**If you have not already done so, read the IBM TotalStorage FAStT EXP100 Storage Expansion Unit Release Notes for important information about the installation and operation of the FAStT EXP100 with FAStT storage servers.**

To enable support for the FAStT EXP100, you *must* perform the following software and firmware support code upgrades:

- FAStT Storage Manager version 8.41 host software upgrade in the host servers and in the management station
- FAStT controller level 5.41.xx.xx firmware and NVSRAM upgrade in the FAStT600 or FAStT900 Storage Servers
- Latest ESM firmware in the FAStT EXP100 expansion unit

The required support code is shipped with the FAStT EXP100 on the *FAStT Storage Manager V8.41 Support for FAStT EXP100 SATA Storage Expansion Unit* CD. In addition, to download the latest version of the FAStT Storage Manager 8.41 host software, the FAStT storage server controller firmware and NVSRAM 5.41.xx.xx, and the latest FAStT EXP100 ESM firmware, go to the following Web site:

[www.ibm.com/storage/support/fastt](http://www.ibm.com/storage/support/fastt)

Refer to the *IBM TotalStorage FAStT Storage Manager 8.4x Installation and Support Guide* for the appropriate operating system for instructions on how to install the FAStT Storage Manager 8.41 host software.

The FAStT EXP100 requires that any connected FAStT storage servers must be upgraded with FAStT controller firmware 5.41.xx.xx. FAStT storage servers can either be ordered from the factory with firmware level 5.41.xx.xx installed or they can be upgraded manually from firmware level 05.40.xx.xx or earlier. See Appendix A, “Upgrading the FAStT controller firmware,” on page 65 for complete instructions on how to manually upgrade the controller firmware from firmware level 05.40.xx.xx or earlier.

**Note:** To upgrade the controller firmware level 05.41.xx.xx and its NVSRAM to a later level, follow the online help in the Subsystem Management window of the FAStT storage server or the instructions in the *IBM TotalStorage FAStT Storage Manager 8.4x Installation and Support Guide*.

**Attention:** Firmware version 05.41.xx.xx is for FAStT storage servers that are connected only to FAStT EXP100 expansion units. It should not be loaded into a FAStT storage server that is connected to any FAStT fibre-channel expansion unit, such as the FAStT EXP700 or FAStT EXP500.

**Important:** After you upgrade the FAStT storage server with controller firmware 5.41.xx.xx, *you cannot downgrade the firmware to an earlier level*. See Appendix A, “Upgrading the FAStT controller firmware,” on page 65 for more information.

Table 6 on page 10 lists the FAStT EXP100 hardware and software compatibility.

**Note:** For the latest information about supported servers and operating systems for the FAStT EXP100, go to the ServerProven® Web site at [www.ibm.com/pc/us/compat/](http://www.ibm.com/pc/us/compat/)

Table 6. FAStT EXP100 hardware and software compatibility

Storage server	Storage management software	Firmware
TotalStorage FAStT600 Fibre Channel Storage Server	IBM FAStT Storage Manager Version 8.41 or later	05.41.xx.xx
TotalStorage FAStT900 Fibre Channel Storage Server	IBM FAStT Storage Manager Version 8.41 or later	05.41.xx.xx

---

## FAStT EXP100 operating environment

This section provides general operating information about the FAStT EXP100. All components plug directly into the backplane.

## FAStT EXP100 specifications

Table 7 lists the specifications for the FAStT EXP100.

Table 7. IBM TotalStorage FAStT EXP100 Storage Expansion Unit specifications

<p><b>Size</b></p> <ul style="list-style-type: none"> <li>• <b>Width:</b> 48.1 cm (18.97 in.)</li> <li>• <b>Height:</b> 13.2 cm (5.21 in.)</li> <li>• <b>Depth:</b> 59.7 cm (23.52 in.)</li> </ul> <p><b>Weight</b></p> <ul style="list-style-type: none"> <li>• Drive-ready weight (without disk drive modules installed): 25.9 kg (57 lb)</li> <li>• Fully configured weight (with 14 disk drives installed): 40.2 kg (88.4 lb)</li> </ul> <p><b>Electrical input</b></p> <ul style="list-style-type: none"> <li>• Sine-wave input (50 - 60 Hz) is required</li> <li>• Input voltage low range: <ul style="list-style-type: none"> <li>– Minimum: 90 V ac</li> <li>– Maximum: 127 V ac</li> </ul> </li> <li>• Input voltage high range: <ul style="list-style-type: none"> <li>– Minimum: 198 V ac</li> <li>– Maximum: 257 V ac</li> </ul> </li> <li>• Input kilovolt-amperes (kVA), approximately: <ul style="list-style-type: none"> <li>– Minimum configuration: 0.06 kVA</li> <li>– Maximum configuration: 0.39 kVA</li> </ul> </li> </ul> <p><b>Environment</b></p> <ul style="list-style-type: none"> <li>• Air temperature <ul style="list-style-type: none"> <li>– Operating: <ul style="list-style-type: none"> <li>- Altitude: 0 - 914 m (3000 ft): 10° - 35° C (50° - 95° F)</li> <li>- Altitude: 914 m - 2133 m (3000 - 7000 ft): 10° - 32° C (50° - 90° F)</li> </ul> </li> <li>– Storage: <ul style="list-style-type: none"> <li>- Altitude: 0 - 914 m (3000 ft): 1° - 60° C (33° - 140° F)</li> </ul> </li> </ul> </li> <li>• Humidity <ul style="list-style-type: none"> <li>– 8% - 80%</li> </ul> </li> </ul>	<p><b>Heat dissipation</b></p> <ul style="list-style-type: none"> <li>• Fully configured expansion unit (14 1.5 Gbps SATA hard disk drives) <ul style="list-style-type: none"> <li>– 1088 BTU per hour</li> </ul> </li> </ul> <p><b>Acoustical noise emission values</b></p> <p>For open bay (0 drives installed) and typical system configurations (eight hard disk drives installed):</p> <ul style="list-style-type: none"> <li>• Sound power (idling): <ul style="list-style-type: none"> <li>– 5.9 bel (open bay)</li> <li>– 6.1 bel (typical)</li> </ul> </li> <li>• Sound power (operating): <ul style="list-style-type: none"> <li>– 5.9 bel (open bay)</li> <li>– 6.2 bel (typical)</li> </ul> </li> <li>• Sound pressure (idling): <ul style="list-style-type: none"> <li>– 44 dBA (open bay)</li> <li>– 46 dBA (typical)</li> </ul> </li> <li>• Sound pressure (operating): <ul style="list-style-type: none"> <li>– 44 dBA (open bay)</li> <li>– 47 dBA (typical)</li> </ul> </li> </ul> <p>These levels are measured in controlled acoustical environments according to ISO 7779 and are reported in accordance with ISO 9296. The declared sound power levels indicate an upper limit, below which a large portion of machines operate. Sound pressure levels in your location might exceed the average 1-meter values stated because of room reflections and other nearby noise.</p>
--	---

### Notes:

1. In general, disk subsystem reliability tends to decrease as the ambient temperature of the environment in which it is being used increases. The ambient temperature in the immediate area of the disk enclosure unit should be kept near 25 degrees C, or lower, to provide better reliability.
2. The nonoperating environment must not exceed the operating environment limits for longer than 60 days.
3. The storage environment must not exceed the operating environment limits for longer than 1 year.

4. Substantial deviations from the suggested operating range, in either direction, if sustained for extended periods of time, will expose the unit to greater risk of failure from external causes.

## Heat output, airflow, and cooling

The maximum heat output of the FAStT EXP100 is 390 watts (1088 BTU/hr). Each FAStT EXP100 rack-mounted unit requires an airflow of 2.5 m<sup>3</sup> (87 ft<sup>3</sup>) per minute. The input air temperature to all racks should be in the range 10° C - 35° C (50° F - 95° F).

**Note:** In general, disk subsystem reliability tends to decrease as the ambient temperature of the environment in which it is being used increases. The ambient temperature in the immediate area of the disk enclosure unit should be kept near 25 degrees C, or lower, to provide better reliability.

When racks that contain many FAStT EXP100s are to be installed together, the following requirements must be met to ensure that the FAStT EXP100s are adequately cooled:

- Air enters at the front of the rack and leaves at the back. To prevent the air that is leaving the rack from entering the intake of another piece of equipment, you must position the racks in alternate rows, back-to-back and front-to-front. This arrangement is known as “cold aisle/hot aisle” and is shown in Figure 8 on page 13.
- Where racks are in rows, each rack must touch the rack that is next to it to reduce the amount of hot air that can flow around from the back of the rack into the intakes of the expansion units that are in that rack. You should use Suite Attach Kits to completely seal any gaps that remain between the racks. For details about Suite Attach Kits, contact your marketing representative.
- Where racks are in rows front-to-front or back-to-back, a gap of at least 1220 mm (48 in.) must separate the rows across the cold aisle.
- To ensure correct airflow in each rack, the rack filler plates must be installed in unused positions. Also, all the gaps in the front of the racks must be sealed, including the gaps between the expansion units.

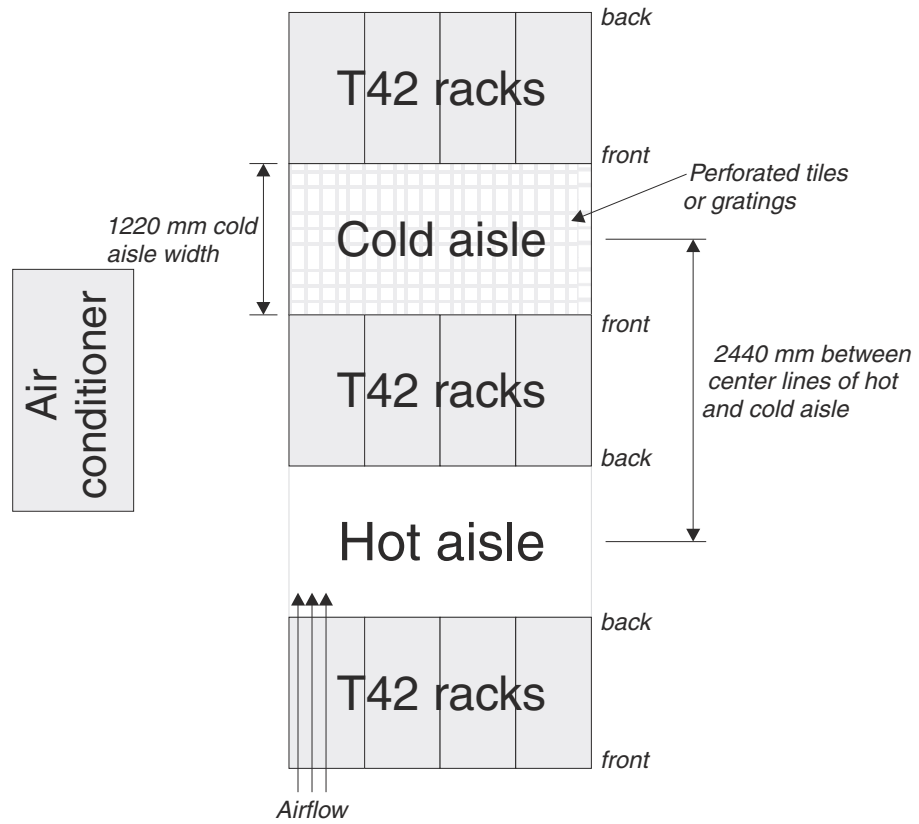

Figure 8. Example of cold aisle/hot aisle rack configuration





## Chapter 2. Installing the FAStT EXP100

This chapter provides the information that you need to prepare the FAStT EXP100 for installation into a rack cabinet. This chapter also contains information about cabling, setting interface options, and installing optional cables.



**Attention:** If you have not already done so, read the *IBM TotalStorage FAStT EXP100 Storage Expansion Unit Release Notes* document for important information about the installation and operation of the FAStT EXP100 with FAStT storage servers.

The following sequence summarizes the installation steps you will perform in this chapter.

1. Prepare the installation site and the rack cabinet. Unpack the FAStT EXP100 and other hardware from the shipping box. See “Preparing for installation” on page 16.

**Statement 4:**



		
≥ 18 kg (39.7 lb)	≥ 32 kg (70.5 lb)	≥ 55 kg (121.2 lb)

**CAUTION:**  
Use safe practices when lifting.

**Attention:** The FAStT EXP100 weighs up to 40.2 kg (88.4 lb). At least two other people should help you lift the FAStT EXP100 from the shipping box. If desired, open the sides of the shipping box and remove the CRUs from the FAStT EXP100 before you lift it from the shipping box in order to lighten the expansion unit. See “Removing the CRUs” on page 22.

2. Install the support rails in the rack. See “Installing the support rails” on page 20.
3. If necessary, remove the CRUs from the FAStT EXP100. See “Removing the CRUs” on page 22.
4. Install the FAStT EXP100. See “Installing the FAStT EXP100 into a rack” on page 26. If necessary, replace the CRUs in the FAStT EXP100. See “Replacing the FAStT EXP100 CRUs” on page 27.
5. Set the FAStT EXP100 interface options. See “Setting the interface options” on page 29.
6. Cable the FAStT EXP100 to other FAStT EXP100s or to a FAStT600 or FAStT900 Storage Server. See “Cabling the FAStT EXP100” on page 31.

7. Install the FAStT Storage Manager 8.41 host software. Refer to the *IBM TotalStorage FAStT Storage Manager 8.4x Installation and Support Guide* for the appropriate operating system for instructions on how to install the FAStT Storage Manager 8.41 host software.
8. Upgrade the controller firmware in the FAStT600 or FAStT900 Storage Server to Version 5.41.xx.xx. See Appendix A, “Upgrading the FAStT controller firmware,” on page 65.

**Note:** If your FAStT storage server shipped preloaded with controller firmware 5.41.xx.xx, you do not need to upgrade the firmware.

9. Turn on the FAStT EXP100. See “Turning the FAStT EXP100 on and off” on page 43.
10. Turn on the FAStT600 or FAStT900 Storage Server and use the FAStT Storage Manager 8.41 host software to verify the configuration.

---

## Handling static-sensitive devices

**Attention:** Static electricity can damage electronic devices and your system. To avoid damage, keep static-sensitive devices in their static-protective packages until you are ready to install them.

To reduce the possibility of electrostatic discharge, observe the following precautions:

- Limit your movement. Movement can cause static electricity to build up around you.
- Handle the device carefully, holding it by its edges or its frame.
- Do not touch solder joints, pins, or exposed printed circuitry.
- Do not leave the device where others can handle and possibly damage the device.
- While the device is still in its static-protective package, touch it to an unpainted metal part of the system unit for at least two seconds. This drains static electricity from the package and from your body.
- Remove the device from its package and install it directly into your system unit without setting it down. If it is necessary to set the device down, place it in its static-protective package. Do not place the device on your system unit cover or on a metal table.
- Take additional care when handling devices during cold weather because heating reduces indoor humidity and increases static electricity.

---



## Preparing for installation

Complete the following steps to prepare the FAStT EXP100 for installation into a rack cabinet.

1. Prepare the site to meet all area, environmental, power, and site requirements. For more information, see “FAStT EXP100 operating environment” on page 10.
2. Move the FAStT EXP100 to the site.

**Statement 4:**



		
≥ 18 kg (39.7 lb)	≥ 32 kg (70.5 lb)	≥ 55 kg (121.2 lb)

**CAUTION:**

**Use safe practices when lifting.**

3. Remove the FAStT EXP100 from its shipping container and check the contents (see “Inventory checklist” on page 2). If any items are missing, contact your IBM reseller before proceeding.
4. Assemble the tools and equipment that you will need for installation. These might include:
  - The power cords that are shipped with the FAStT EXP100
  - Number 2 Phillips and medium flat-blade screwdrivers
  - Antistatic protection (such as a grounding wrist strap)
  - Fibre Channel (FC) and Ethernet interface cables and cable straps
  - SFP modules
  - The rack-mounting hardware that ships with the FAStT EXP100
  - IBM FAStT Storage Manager 8.41 software and FAStT storage server controller firmware 05.41.xx.xx (if your controller did not ship with the 05.41.xx.xx firmware installed) that ships with the FAStT EXP100. You use this software to configure the storage subsystems.
5. Continue with “Preparing the site.”

## Preparing the site

This section lists the floor space requirements and weight information for the FAStT EXP100. For information on interface cables and connections, see “Cabling the FAStT EXP100” on page 31.

**Floor space:** The floor area at the installation site must provide the following conditions:

- Enough stability to support the weight of the fully configured FAStT EXP100 and associated systems
- Sufficient space to install the FAStT EXP100

**Weight:** The FAStT EXP100 total weight depends on the number of FAStT 1.5 Gbps SATA hard disk drives that are installed. A fully configured FAStT EXP100 with two fans, two power supplies, two ESMs, and up to 14 SATA hard disk drives installed weighs 40.2 kg (88.4 lbs).

Continue with “Preparing the rack.”

## Preparing the rack

**Important:** Before you install the FAStT EXP100 in a rack, keep in mind the following considerations:

- Review the documentation that comes with your rack enclosure for safety and cabling considerations.
- Install the FAStT EXP100 in a maximum 35° C (95° F) environment.
- To ensure proper airflow, do not block the air vents; 15 cm (6 in.) of air space is sufficient.
- To ensure rack stability, load the rack starting at the bottom.
- If you install multiple components in the rack, do not overload the power outlets.
- Always connect the expansion unit to a properly grounded outlet.

Complete the following steps to prepare the rack before you install the FAStT EXP100:

1. Move, unpack, and level the rack at the installation site (if needed).
2. Remove the external rack panels.
3. If necessary, stop all I/O activity to the devices in the rack.
4. If necessary, turn off all drive enclosure and rack power. Disconnect existing power, network, and other external cables.
5. Install any additional interface cables and power cables.

After you have completed these steps, continue with “Installing the FAStT EXP100.”

---

## Installing the FAStT EXP100

This section provides instructions on how to install the FAStT EXP100 in a rack.

### Rack mounting template

**Attention:** Duplicate copies of the rack mounting templates are provided in Appendix D, “Rack mounting template,” on page 79. If you want to tear out the templates from this document for easier use, use the copies in Appendix D, “Rack mounting template,” on page 79 rather than the copies provided in this section.

Use the following templates (Figure 9 on page 19 and Figure 10 on page 20) to identify the proper locations for inserting M6 screws when mounting the support rails and FAStT EXP100 to a rack. The locations for the M6 screws are highlighted in the templates.

The FAStT EXP100 is 3 U high. Align the template with the rack at a U boundary. U boundaries are shown as horizontal dashed lines in the rack mounting templates.

**Note:** The mounting holes that are shown in the following templates are square. The holes in your rack might be round, square, or threaded.

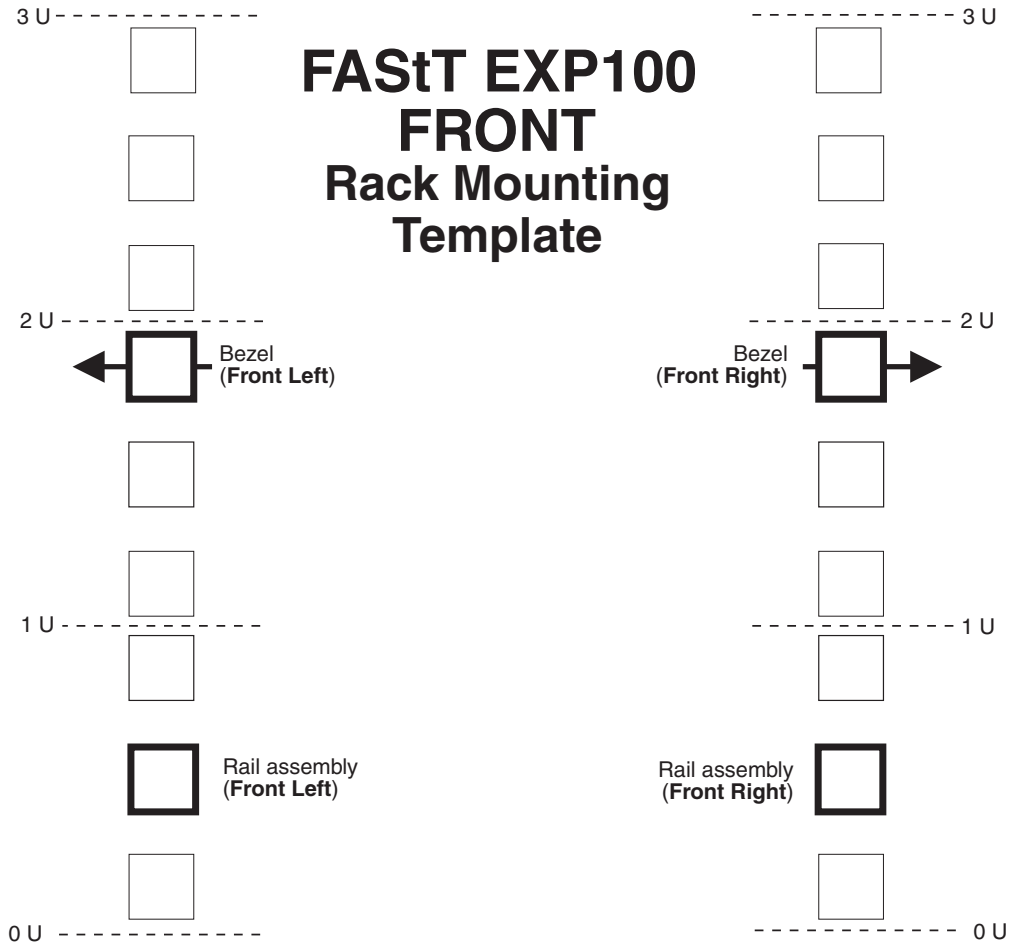

Figure 9. Front rack mounting template

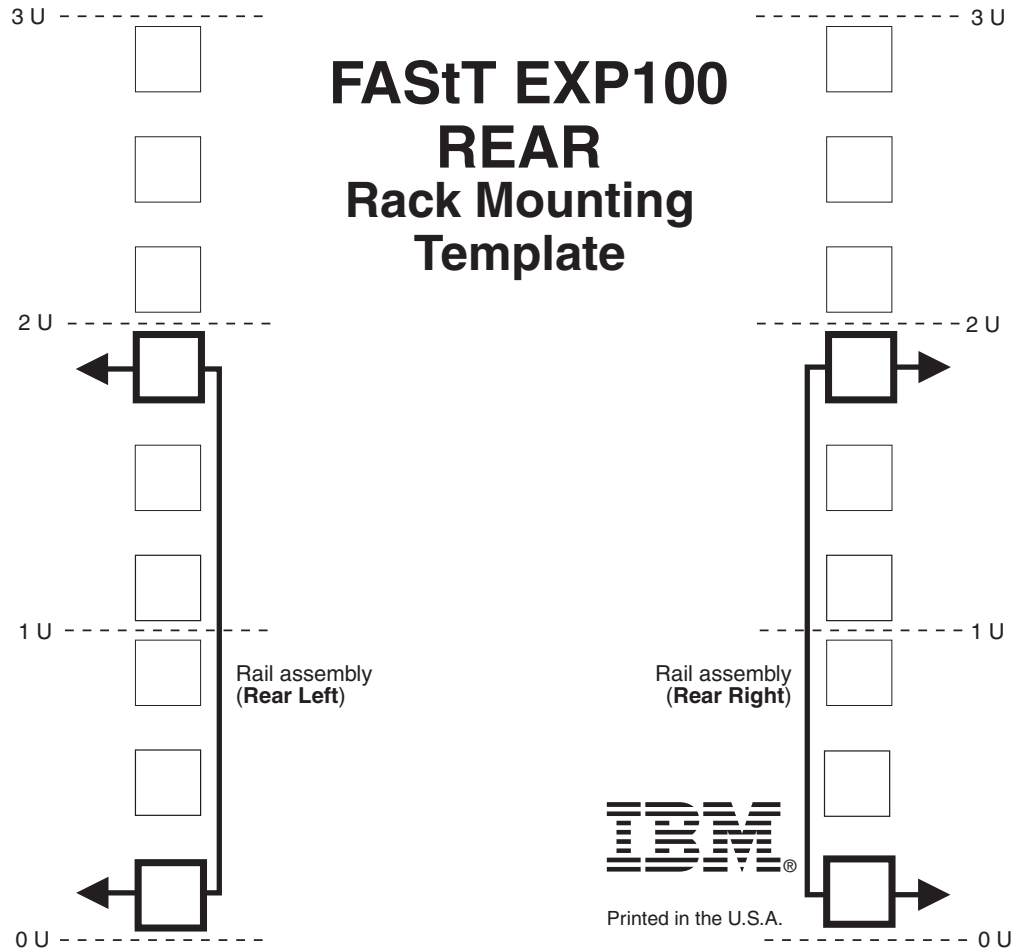

Figure 10. Rear rack mounting template

## Installing the support rails

Before installing the FASTt EXP100 in a rack, you must install the rails and rack-mounting hardware that come with your expansion unit. The FASTt EXP100 requires an Electronic Industries Association (EIA) 310-D Type A 19-inch rack cabinet. The distance between EIA rails, from the front to the rear of the rack, is 60.96 cm (24 in.) minimum and 81.28 cm (32 in.) maximum. This rack conforms to the EIA standard. Where you place the support rails in the rack depends on where you intend to position the expansion unit.

Complete the following steps to install the support rails:

**Note:** Refer to Figure 12 on page 22 while performing these steps.

1. Ensure that the rack has already been installed.
2. Ensure that a stabilizer has been correctly attached to the bottom front of the rack to prevent the rack from tipping forward while the FASTt EXP100 is being installed.

Refer to the installation and service guide, or equivalent, for the rack as required.

3. Locate the two support rails and six of the eight M6 screws that are supplied with the FASTt EXP100.

**Attention:** Both support rails are shipped with three screws and spacers, called *alignment pins*, already installed at the front of each rail. They have been inserted in the front of each support rail as guides to indicate where *not* to use M6 screws when you attach the front of the support rail to the rack. See Figure 11.

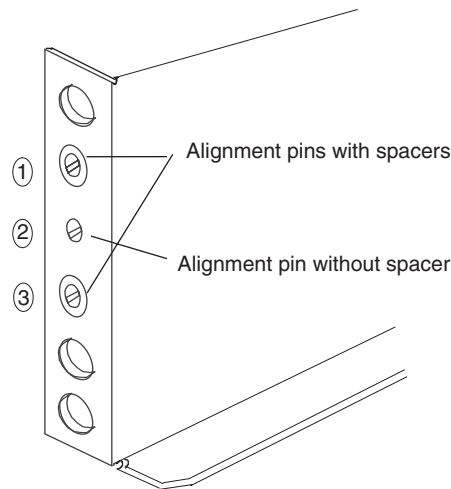

Figure 11. Alignment pins with and without spacers

Depending on which type of rack mounting flange is present on your rack, you might have to remove some or all of the alignment pins. For example, if the rack in which you are installing the support rails has round holes, you will need to remove the spacers from the top and bottom alignment pins so that the rail sits flush with the rack. See Table 8.

Table 8. Alignment pin requirements for different rack flange hole types

Rack flange type	Pins to remove
Square hole	None
Round hole	1 and 3
Threaded hole	All

- The rack-mounted unit is three EIA units high. Decide accordingly where you are going to install the support rails.

**Attention:** Use the rack mounting template provided in Figure 9 on page 19 and Figure 10 on page 20 to locate the proper rack mounting holes for installing the support rails into the rack.

Note the following considerations before you choose where to install the rails:

- If you are installing the FAStT EXP100 into an empty rack, install it into the lowest available position so that the rack does not become unstable.
- If you are installing more than one FAStT EXP100 in the rack, start at the lowest available position, and work upward.
- If appropriate, allow for possible later installation of other units.
- If necessary, remove the rack power distribution unit before you install the support rails.
- For procedures and more information, refer to the installation and service guide, or equivalent, for the rack.

- Starting with the left rail, remove and save the 6/32 in. screw ( **5** ). Loosen the four rail adjustment screws ( **2** ).

**Note:** The support rails are not marked as Left or Right. However, each rail can be correctly mounted on only one side of the rack cabinet. The rails should be mounted with the alignment pins at the front of the rack. Figure 12 shows the installation of the left support rail.

- Hold the front of the rail against the inside of the right rack-mounting flange and loosely tighten the lower M6 screw ( **4** ). See Figure 9 on page 19 for the location for this screw.
- Extend the rear of the support rail until it makes contact with the rear rack rail.
- From the rear of the rack, thread and tighten two M6 screws ( **1** ) (see Figure 10 on page 20 for the location for these screws). From the front of the rack, finish tightening the front M6 screw ( **4** ).

When you are finished, the rail should be attached to the cabinet using one M6 screw in the front (inserted at the second-to-lowest hole) and two M6 screws at the back.

- Repeat step 5 through step 8 for the right rail.

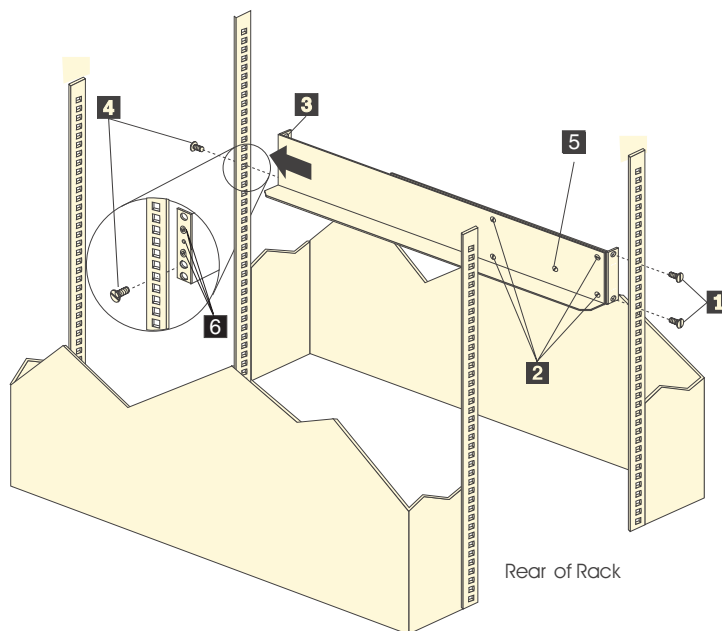

Figure 12. Installing the support rails

- Tighten the rail adjustment screws **2** on both rails.
- Continue with “Removing the CRUs.”

## Removing the CRUs

**Attention:** This section describes how to remove the CRUs in order to minimize the weight of the FASt EXP100 before you install it in the rack. However, if you have three or more people available to lift and install the FASt EXP100 in a rack, you might not find it necessary to remove the CRUs before you install the FASt EXP100. If this is the case, you can skip the CRU removal instructions provided in this section. Instead, continue with “Installing the FASt EXP100 into a rack” on page 26, and then skip the CRU replacement instructions provided in “Replacing the FASt EXP100 CRUs” on page 27.



Use the following procedures to remove the CRUs from the FAStT EXP100 before installation. Use these instructions after you have completed all applicable site, rack, and FAStT EXP100 preparations (as discussed in “Preparing for installation” on page 16) and installed the support rails (as discussed in “Installing the support rails” on page 20). Alternately, if necessary, you can use these instructions to lighten the FAStT EXP100 before removing it from the shipping box. The shipping box opens to provide access to the expansion unit CRUs.



The FAStT EXP100 comes with a rack-mounting hardware kit for installing it in a rack. It is easier to lift the FAStT EXP100 and install it in a rack cabinet if you remove all the CRUs first. You will need an antistatic wrist strap and a cart or level surface (to hold the CRUs). Observe the precautions listed in “Handling static-sensitive devices” on page 16. In the following procedure, you will remove the following CRUs from the expansion unit before you install it in the rack:

- ESMs
- Power supplies
- Fans
- Hot-swap hard disk drives

You do not need to remove the blank trays.

**Statement 4:**



		
≥ 18 kg (39.7 lb)	≥ 32 kg (70.5 lb)	≥ 55 kg (121.2 lb)

**CAUTION:**  
Use safe practices when lifting.

**Attention:** The expansion unit comes with a bezel that is attached to the front of the unit. The bezel protects the light pipes that are located above the drive trays. Leave the protective bezel in place until you are instructed to remove it.

**Removing an ESM**

Complete the following steps to remove an ESM:

1. Push down on the ESM latch. While holding down the ESM latch, grasp the pull rings and pull out on the levers to disconnect the ESM from the FAStT EXP100 midplane.
2. Remove the ESM from the bay, as shown in Figure 13 on page 24.

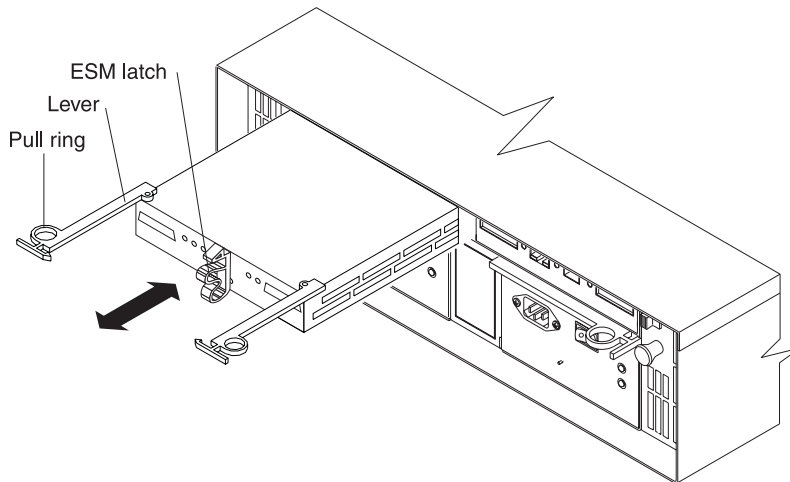

Figure 13. Removing an ESM

3. Place the ESM on a level surface.
4. Repeat step 1 through step 3 for the second ESM.

### Removing a power supply

Complete the following steps to remove a power supply:

1. Grasp the pull-ring on the power supply lever and squeeze the latch to release it.
2. Pull the lever open 90° and remove the power supply, as shown in Figure 14.

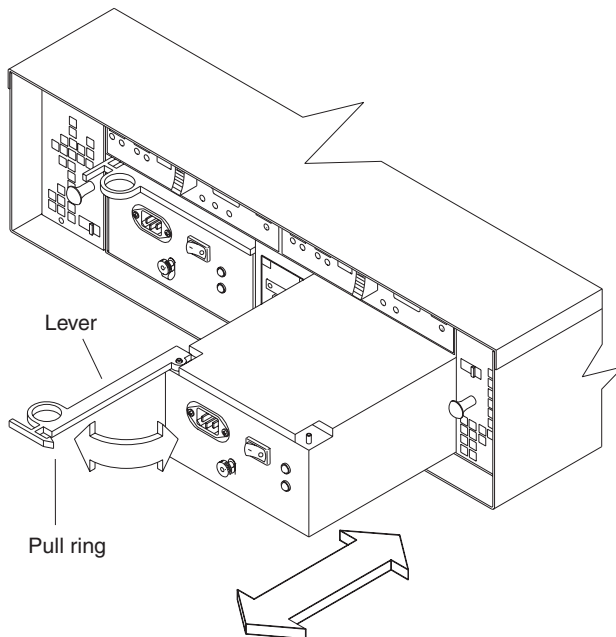

Figure 14. Removing a power supply

3. Place the power supply on a level surface.
4. Repeat step 1 through step 3 for the second power supply.

### Removing a fan

Complete the following steps to remove a fan:

1. Unlock the latch by moving the latch in the same direction as the latch direction arrow shown on the back of the fan.
2. Grasp the handle and pull the fan unit out of the bay, as shown in Figure 15.

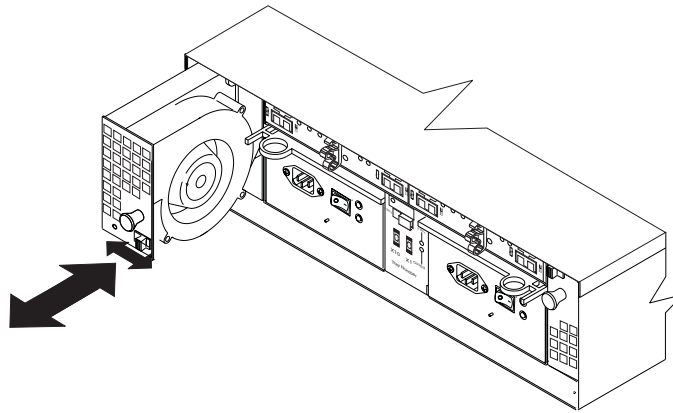

Figure 15. Removing a fan unit

3. Place the fan unit on a level surface.
4. Repeat step 1 through step 3 for the second fan unit.

### Removing a hard disk drive

Complete the following steps to remove a hot-swap hard disk drive:

**Note:** The hard disk drive comes installed in a drive tray. Do not attempt to detach the drive from the tray.

1. Use Table 11 on page 77 to record the location and identify your FAStT SATA hard disk drives. You must record this information to be able to replace the hard disk drives in their original order before they were removed.
2. Release the latch on the drive CRU by pinching together the blue line on the tray latch and the finger hole on the tray handle.
3. Pull the tray handle out so that it is in the open position to release the drive CRU. Pull the drive out of the bay, as shown in Figure 16.

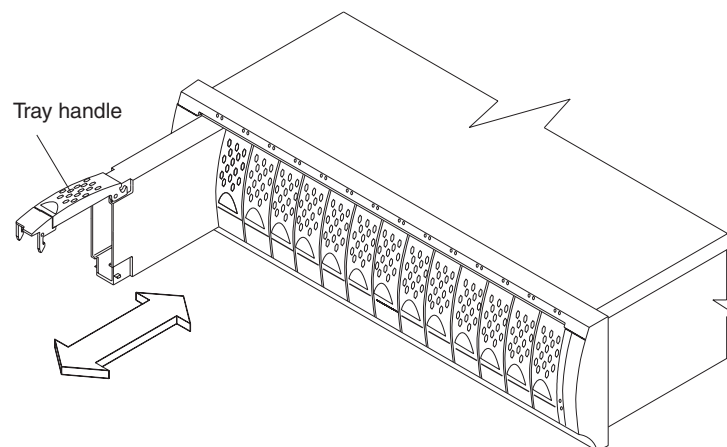

Figure 16. Removing a drive CRU

4. Place the drive CRU horizontally on a level surface.

**Attention:** Do not stack drive CRUs on top of one another.

5. Repeat step 1 through step 4 for additional drive CRUs.

Continue with “Installing the FAStT EXP100 into a rack.”

## Installing the FAStT EXP100 into a rack

Complete the following steps to install the FAStT EXP100 in the rack.

1. Place the FAStT EXP100 in the rack.

**Note:** If you have removed the CRUs from the FAStT EXP100, you should be able to lift the unit into the cabinet with the help of one other person. If you have not removed the CRUs before the installation, you should have at least two other people available to help you lift the unit into the rack.

- a. Move the FAStT EXP100 to the front of the rack-mount cabinet.
- b. With help from another person, place the back of the expansion unit on the support rails. Slide the unit into the rack, as shown in Figure 17.

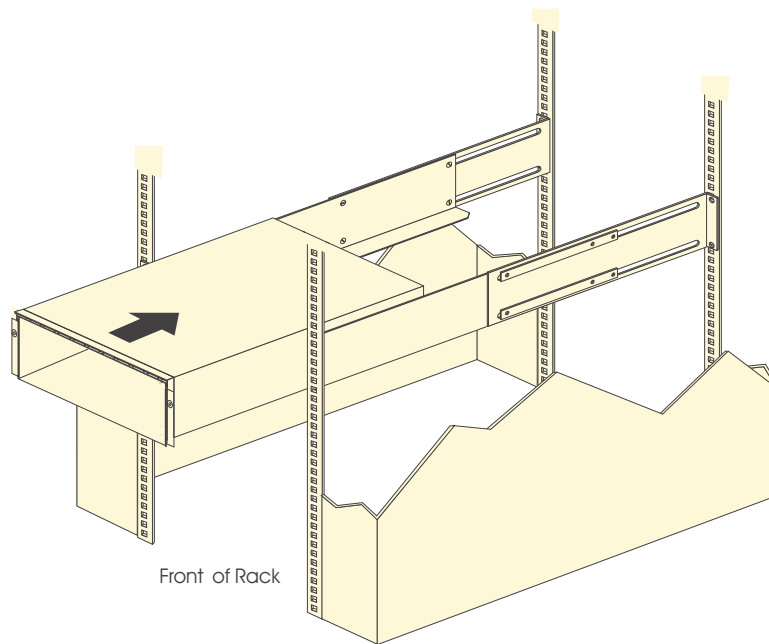

Figure 17. Installing the FAStT EXP100

2. The bezel is secured to the front of the FAStT EXP100 either by plastic wingnuts or by adhesive tape. Remove and discard the wingnuts or the adhesive tape. The bezel should remain attached to the FAStT EXP100 chassis.

**Attention:** The bottom cross member of the bezel has a tab that must fit beneath the FAStT EXP100 chassis and snap into place. The top cross member of the bezel has a recess that must be mated with a metal tab on the bottom of the FAStT EXP100 chassis.

3. Secure the FAStT EXP100 to the rack:
  - a. Align the front mounting holes on each side of the expansion unit with the mounting holes on the front of the support rails.
  - b. Install the bezel.

- c. Insert an M6 screw into the upper mounting hole on both sides of the front of the unit (see Figure 9 on page 19). Gently tighten the screws to secure the bezel and the front of the FAStT EXP100 to both of the front cabinet rails.
 

**Attention:** Do not overtighten. If you overtighten these screws, you could break the bezel.
- d. From the back of the rack, insert the two 6/32 in. screws ( **5** in Figure 12 on page 22), one on each side, in the holes on the side of the unit. Tighten the screws.
4. Continue with one of the following actions:
  - If you did remove the FAStT EXP100 CRUs before installation (as described in “Removing the CRUs” on page 22), continue with “Replacing the FAStT EXP100 CRUs.”
  - If you did not find it necessary to remove the FAStT EXP100 CRUs before installation, continue with “Setting the interface options” on page 29.

## Replacing the FAStT EXP100 CRUs

Use the following procedures to replace the CRUs in the FAStT EXP100 after installation.

### Replacing an ESM

Complete the following steps to replace the ESM that you removed before the installation:

1. Slide one ESM into the empty slot in the expansion unit. Be sure that the levers are pulled straight out as you slide the ESM in, as shown in Figure 18.

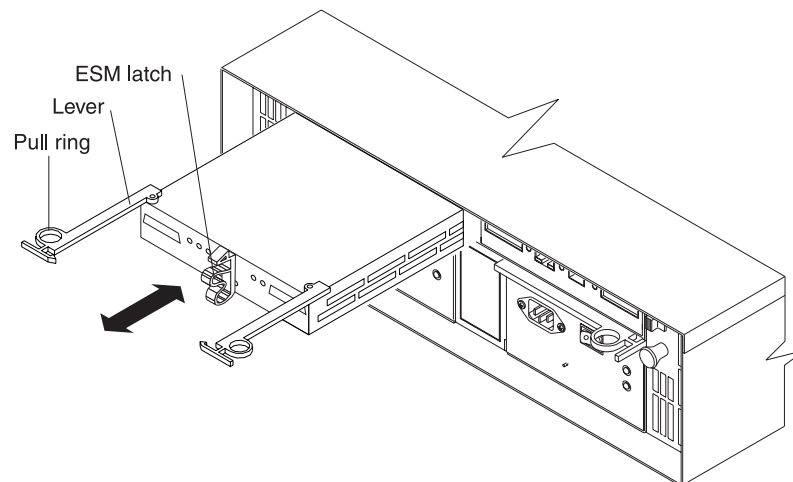

Figure 18. Replacing an ESM

2. After you install the ESM into the bay, the ESM latch locks into place. Close the levers until the pull-ring latches lock in place.

**Attention:** Make sure that the levers lock into place in the expansion unit chassis.

3. Repeat step 1 and step 2 to replace the second ESM.

### Replacing a power supply

Complete the following steps to replace the power supplies that you removed before the installation:

1. Slide one power supply into the expansion unit. Be sure to replace the power supplies so that the lever on each power supply opens toward the interior of the expansion unit, as shown in Figure 19.

**Attention:** Be sure that the lever is pulled straight out as you slide the power supply into the expansion unit, as shown in Figure 19.

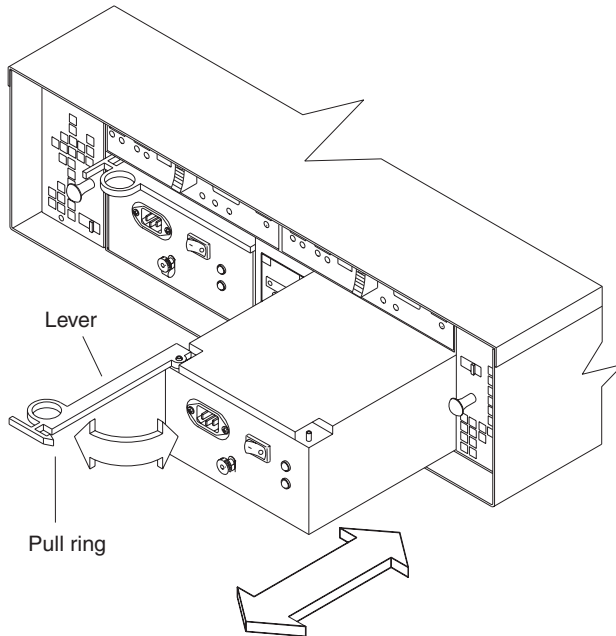

Figure 19. Replacing a power supply

2. Close the lever until the pull-ring latch locks in place. Make sure that the lever locks into place in the expansion unit chassis. Then gently push the front of the power supply to ensure that it is fully seated.
3. Repeat step 1 and step 2 to replace the second power supply.

### Replacing a fan

Complete the following steps to replace the fan units that you removed before the installation:

1. Place the fan in front of the fan bay.
2. Ensure that you move the fan latch in the same direction as the arrow before you slide the fan all the way into the bay. If the fan does not go into the bay, rotate it 180° (see Figure 20 on page 29).

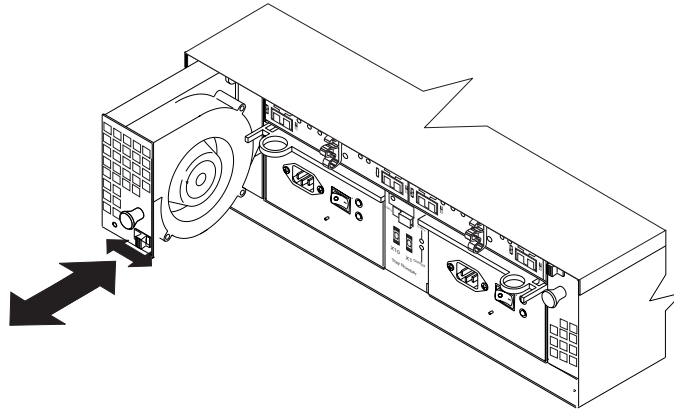

Figure 20. Replacing a fan

3. If the latch does not automatically lock when you have successfully inserted the fan unit into the bay, pull back slightly on the fan and then push it in again until the latch snaps into place.
4. Repeat step 1 through step 3 to replace the second fan.

### Replacing a hard disk drive

Complete the following steps to replace the hot-swap hard disk drives that you removed before the installation.

**Note:** Use Table 11 on page 77 to verify the proper replacement locations of your FAStT 1.5 Gbps SATA hard disk drives.

1. Lift up on the handle and gently push the drive CRU into the empty bay until the hinge of the tray handle latches beneath the expansion unit bezel.
2. Push the tray handle down until the latch clicks into place.
3. Repeat step 1 and step 2 to replace additional drives.

---

## Setting the interface options

The FAStT EXP100 has two enclosure ID switches that identify the FAStT EXP100 on a fibre-channel loop and that assign physical addresses to the drives. The enclosure ID switches are located on the back of the expansion unit, as shown in Figure 21 on page 30.

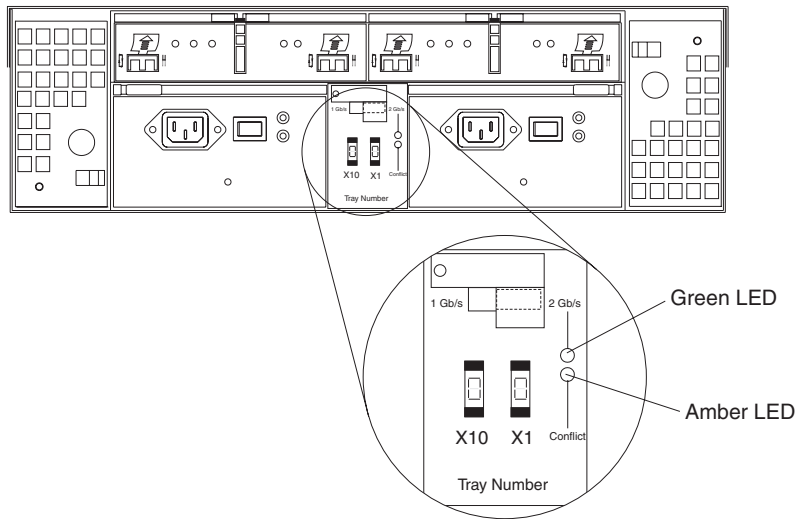

Figure 21. Enclosure ID switches

## Fibre-channel loop and ID settings

When you install a hard disk drive in the expansion unit, the drive tray plugs into a printed circuit board called the *midplane*. The midplane sets the fibre-channel loop ID automatically, based on the enclosure ID switch setting and the physical location (bay) of the hard disk drive.

## Enclosure ID settings

Enclosure ID switch settings (values 0 - 7) set various addresses and IDs. Use enclosure ID switch X1 to set the ones position, and use enclosure ID switch X10 to set the tens position. The settings of the two enclosure ID switches, when used together, provide a two-digit ID of the expansion unit. The storage management software uses the enclosure ID to provide a correlation between the storage management graphics and the physical expansion unit. The ID indicates which physical unit corresponds to the storage management software status.

Use the push buttons on the enclosure ID switches X10 and X1 to set the expansion unit ID to any value from 0 - 77. See Figure 22 on page 31. Each expansion unit that is connected to a fibre-channel controller should have a unique ID. The ID must be different from all other expansion units that are connected to the storage server. Refer to your storage server documentation for more information.



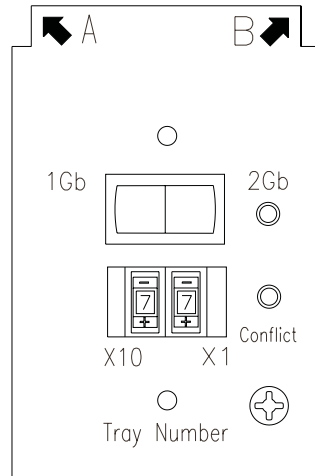

Figure 22. Enclosure ID settings

## Expansion unit speed settings

The default switch setting is 2 Gbps. This is the *only* speed setting allowed for the FAStT EXP100.

**Attention:** Do not remove the metal plate that covers the expansion unit speed setting. Do not adjust the expansion unit speed setting.

---

## Cabling the FAStT EXP100

The FAStT EXP100 supports two redundant drive loops. A redundant FAStT EXP100 drive loop consists of one or more expansion units that are connected to a storage server using two sets of fibre-channel cables. If one fibre-channel drive loop fails, the storage server uses the other drive loop to maintain input/output (I/O) to the FAStT EXP100 drives. Usually, there are two redundant array of independent disks (RAID) controllers in a storage server. Use the *Fibre Channel Cabling Instructions* that ships with your storage server for the specific information about cabling the FAStT EXP100. Before cabling the expansion unit, read the following information:

- **Fibre-channel loop:** A fibre-channel loop consists of fibre-channel disk drives that are connected to each other and to one or more RAID controllers. A loop can support multiple RAID controllers, a large number of disk drives, and other addressable entities such as system-management logic chips. Refer to your storage server documentation for information about controller-dependent hardware configuration. Some controllers might have restrictions on the maximum number of disk drives that can be supported on a loop, cabling restrictions, and other requirements.
- **SFP module ports:** The FAStT EXP100 supports large, complex, and redundant disk drive loop configurations. Each ESM has two SFP module ports. Each SFP module has an input and output port. A loop is created by connecting one or more FAStT EXP100 expansion units to one or more RAID controllers.
- **Fibre-channel cable restrictions:** RAID controllers use specific IBM fibre-channel options. Refer to the *Fibre Channel Cabling Instructions* that come with your storage server for the cable option that is required for your configuration.

- **Power cabling:** The FAStT EXP100 uses two standard power cables. You can connect the power cables to a primary power unit inside the rack, such as a properly grounded ac distribution unit or uninterruptible power supply. You can also connect the power cable to an external source, such as a properly grounded electrical outlet.

**Note:** To ensure maximum availability of power to your FAStT EXP100, do not connect both the left and right power supplies to the same power circuit or power source.

## Installing SFP modules

The FAStT EXP100 requires SFP modules. SFP modules convert electrical signals to optical signals that are required for Fibre Channel transmission to and from RAID controllers. After you install the SFP modules, you use fiber-optic cables to connect the FAStT EXP100 to a FAStT600 or a FAStT900.

Before installing SFP modules and fiber-optic cables, read the following information:

- The SFP module housing has an integral guide key that is designed to prevent you from inserting the SFP module improperly.
- Use minimal pressure when inserting an SFP module into an SFP port. Forcing the SFP module into a port could cause damage to the SFP module or to the port.
- You can insert or remove the SFP module while the port is powered on.
- The operational or redundant loop performance is not affected when you install or remove an SFP module.
- You must insert the SFP module into a port before you connect the fiber-optic cable.
- You must remove the fiber-optic cable from the SFP module before you remove the SFP module from the port. Refer to “Removing SFP modules” on page 34 for more information.

Complete the following steps to install an SFP module:

**Statement 3:**



**CAUTION:**

When laser products (such as CD-ROMs, DVD drives, fiber optic devices, or transmitters) are installed, note the following:

- Do not remove the covers. Removing the covers of the laser product could result in exposure to hazardous laser radiation. There are no serviceable parts inside the device.
- Use of controls or adjustments or performance of procedures other than those specified herein might result in hazardous radiation exposure.



**DANGER**

Some laser products contain an embedded Class 3A or Class 3B laser diode. Note the following.

Laser radiation when open. Do not stare into the beam, do not view directly with optical instruments, and avoid direct exposure to the beam.

**Attention:** When you handle static-sensitive devices, take precautions to avoid damage from static electricity. For details about handling static-sensitive devices, see “Handling static-sensitive devices” on page 16.

1. Remove the SFP module from its static-protective package.
2. Remove the protective cap from the SFP module, as shown in Figure 23. Save the protective cap for future use.

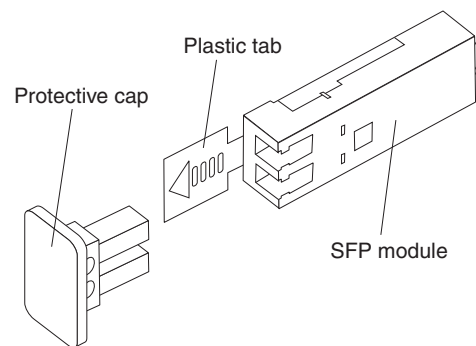

*Figure 23. SFP module and protective cap*

3. Remove the protective cap from the SFP port. Save the protective cap for future use.
4. Insert the SFP module into the host port until it clicks into place. See Figure 24 on page 34.

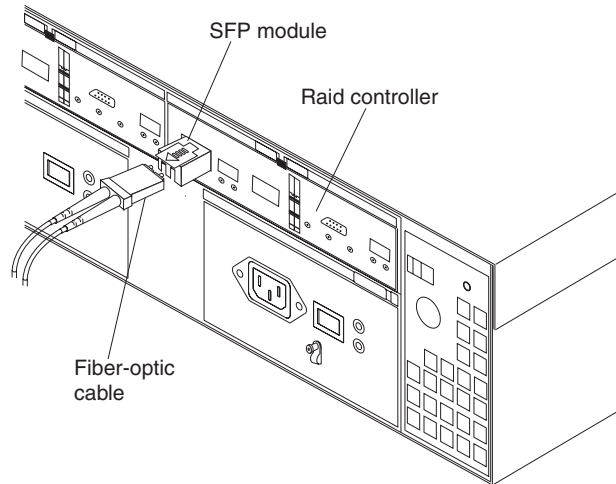

Figure 24. Installing an SFP module into the host port

5. Connect an LC-LC fibre-channel cable. For information about the LC-LC cable, see "Using LC-LC fibre-channel cables" on page 35.

## Removing SFP modules

Complete the following steps to remove the SFP module from the host port:

**Attention:** To avoid damage to the cable or to the SFP module, make sure that you unplug the LC-LC fibre-channel cable *before* you remove the SFP module.

1. Remove the LC-LC fibre-channel cable from the SFP module. For more information, see "Handling fiber-optic cables" on page 35.
2. Unlock the SFP module latch:
  - For SFP modules that contain plastic tabs, unlock the SFP module latch by pulling the plastic tab outward 10°, as shown in Figure 25.

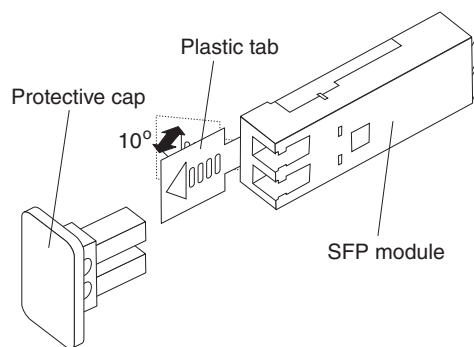

Figure 25. Unlocking the SFP module latch - plastic variety

- For SFP modules that contain wire tabs, unlock the SFP module latch by pulling the wire latch outward 90°, as shown in Figure 26 on page 35.

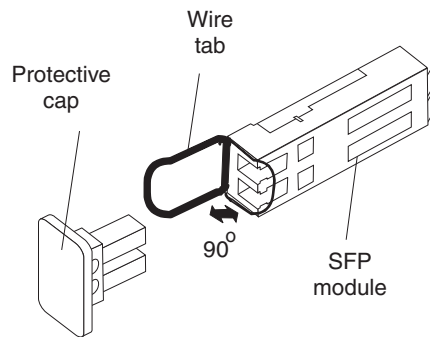

Figure 26. Unlocking the SFP module latch - wire variety

3. With the SFP latch in the unlocked position, extract the SFP module.
  - For SFP modules that contain plastic tabs, slide the SFP module out of the port.
  - For SFP modules that contain wire tabs, grasp the wire latch and pull the SFP module out of the minihub port.
4. Replace the protective cap on the SFP module.
5. Place the SFP module into a static-protective package.
6. Replace the protective cap on the host port.

## Handling fiber-optic cables

**Attention:** To avoid damage to your fiber-optic cables, follow these guidelines:

- Do not route the cable along a folding cable-management arm.
- When connecting cables to a device on slide rails, leave enough slack in the cable so that it does not bend to a radius of less than 38 mm (1.5 in.) when extended or become pinched when retracted.
- Route the cable away from places where it can be snagged by other devices in the rack.
- Do not overtighten the cable straps or bend the cables to a radius of less than 38 mm (1.5 in.).
- Do not put excess weight on the cable at the connection point. Be sure that the cable is well supported.

## Using LC-LC fibre-channel cables

The LC-LC fibre-channel cable is a fiber-optic cable that you use to connect into one of the following devices:

- An SFP module installed in an IBM FAStT EXP100 Storage Expansion Unit
- An SFP module installed in an IBM FAStT600 or FAStT900 Fibre Channel Storage Server

See Figure 27 on page 36 for an illustration of the LC-LC fibre-channel cable.

For more information about cabling these devices, see the documentation that comes with the LC-LC fibre-channel cable.

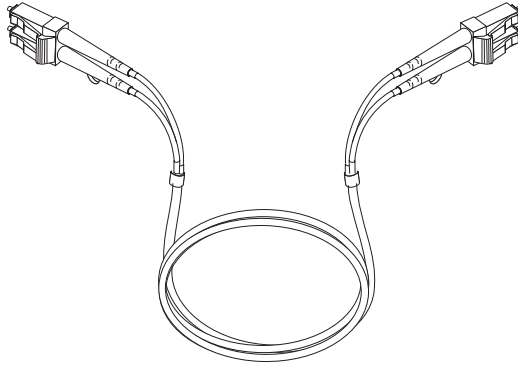

Figure 27. LC-LC fibre-channel cable

### Connecting an LC-LC cable to an SFP module

Complete the following steps to connect an LC-LC fibre-channel cable to an SFP module:

#### Statement 3:



#### CAUTION:

When laser products (such as CD-ROMs, DVD drives, fiber optic devices, or transmitters) are installed, note the following:

- Do not remove the covers. Removing the covers of the laser product could result in exposure to hazardous laser radiation. There are no serviceable parts inside the device.
- Use of controls or adjustments or performance of procedures other than those specified herein might result in hazardous radiation exposure.



#### DANGER

Some laser products contain an embedded Class 3A or Class 3B laser diode. Note the following.

Laser radiation when open. Do not stare into the beam, do not view directly with optical instruments, and avoid direct exposure to the beam.

1. Read the information in “Handling fiber-optic cables” on page 35.
2. If necessary, remove the protective cap from the SFP module, as shown in Figure 23 on page 33. Save the protective cap for future use.
3. Remove the two protective caps from one end of the LC-LC cable, as shown in Figure 28 on page 37. Save the protective caps for future use.

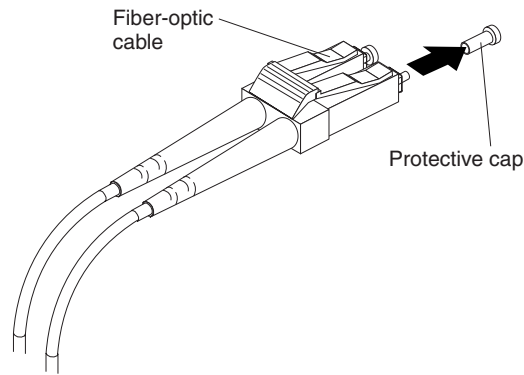

Figure 28. Removing fiber-optic cable protective caps

4. Carefully insert this end of the LC-LC cable into an SFP module that is installed in the FAStT EXP100. The cable connector is keyed to ensure it is inserted into the SFP module correctly. Holding the connector, push in the cable until it clicks into place, as shown in Figure 29.

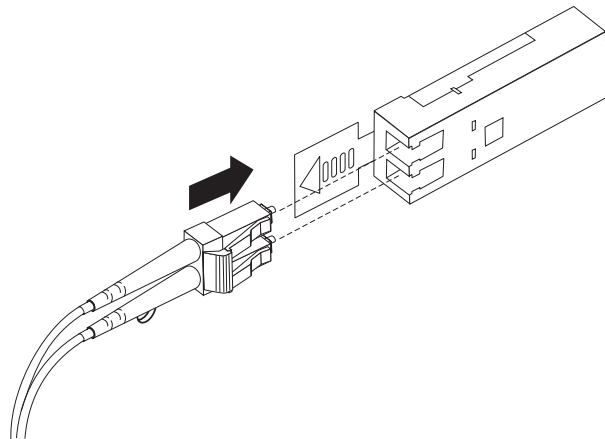

Figure 29. Inserting an LC-LC fibre-channel cable into an SFP module

5. Remove the two protective caps from the other end of the LC-LC cable. Save the protective caps for future use.
6. Connect this end of the LC-LC cable to one of the following devices:
  - An SFP module that is installed in a separate FAStT EXP100
  - An SFP module that is installed in a FAStT600 or FAStT900

### Removing an LC-LC fibre-channel cable

Complete the following steps to remove an LC-LC fibre-channel cable:

**Attention:** To avoid damaging the LC-LC cable or SFP module, make sure that you press and hold the lever to release the latches before you remove the cable from the SFP module. Ensure that the levers are in the released position when removing the cable. When removing the cable from the SFP module, make sure that you do not grasp the SFP module plastic tab.

1. On the end of the LC-LC cable that connects into the SFP module or host bus adapter, press down and hold the lever to release the latches, as shown in Figure 30 on page 38.

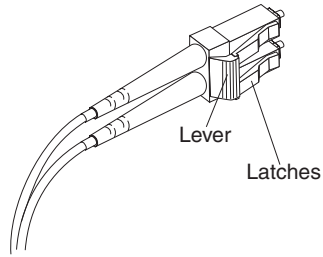

Figure 30. LC-LC fibre-channel cable lever and latches

2. Carefully pull on the connector to remove the cable from the SFP module, as shown in Figure 31.

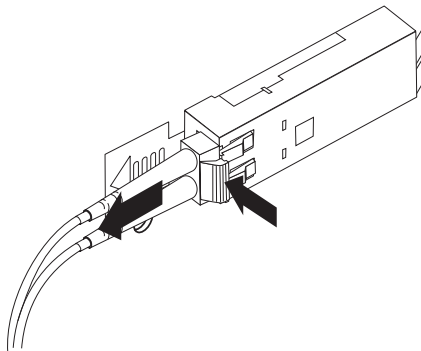

Figure 31. Removing the LC-LC fibre-channel cable

3. Replace the protective caps on the cable ends.
4. Replace the protective cap on the SFP module.

## Cabling the FAStT EXP100 to a FAStT600 and FAStT900

You can cable the FAStT EXP100 to a FAStT600 Storage Server or FAStT900 Fibre Channel Storage Server. To cable the expansion unit to a FAStT600 or to a FAStT900, you need optional LC-LC cables.

### Cabling the FAStT EXP100 to a FAStT600 Storage Server

Complete the following steps to cable the FAStT EXP100 to a FAStT600:

**Attention:** When the FAStT600 Storage Server is connected to a FAStT EXP100, the storage server must not have fibre-channel drives inserted in its slots. All the slots in the FAStT600 Storage Server must have blank drive trays to ensure proper cooling.

1. Install an SFP in a drive port on the FAStT600 Storage Server.
2. Connect the fiber-optic cable to the installed SFP, as shown in Figure 32 on page 39.



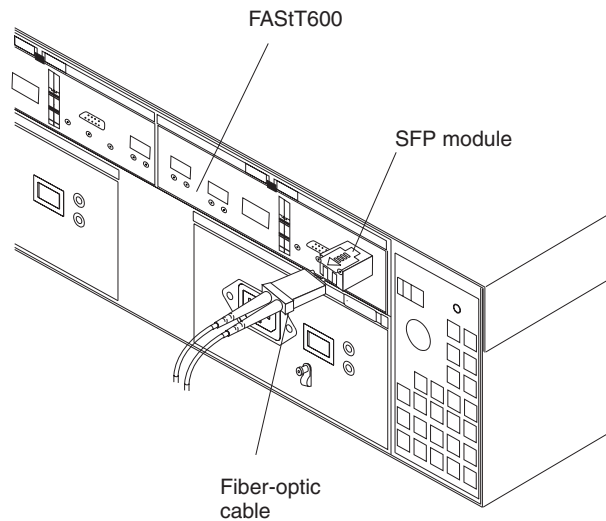

Figure 32. Connecting cables to the installed SFP

3. Insert an SFP module into the SFP port located on the back of the FAST EXP100; then, connect the other end of the LC-LC cable to the SFP module, as shown in Figure 33.

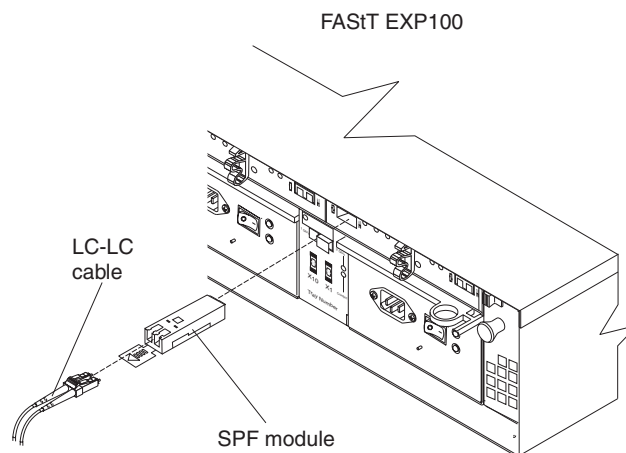

Figure 33. Installing an SFP module and connecting an LC-LC cable to the FAST EXP100

### Cabling the FAST EXP100 to a FAST900 Fibre Channel Storage Server

Complete the following steps to cable the FAST EXP100 to a FAST900 Fibre Channel Storage Server:

1. Install an SFP module in the drive mini hub port on the back of a FAST900 Fibre Channel Storage Server.
2. Connect an LC-LC fiber-optic cable into the SFP module, as shown in Figure 34 on page 40.

**Note:** The FAST900 supports two redundant drive loops with four drive mini-hubs. Because each drive mini-hub supports only one drive loop, you can use only one of the two ports in each of the FAST900 drive mini-hubs. Do not insert SFPs in the unused mini-hub ports.

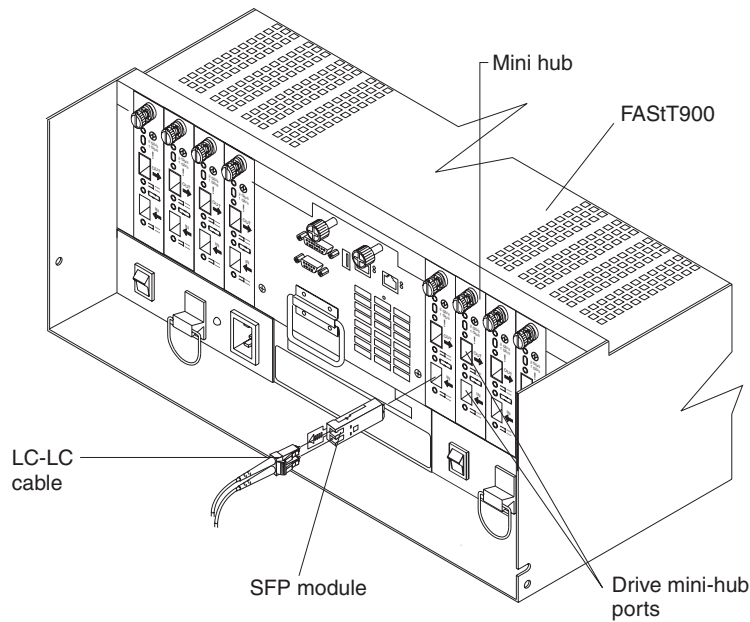

Figure 34. Installing an SFP module and LC-LC cable in a FAST900

3. Install an SFP module in the SFP port on the back of the FASTt EXP100; then, connect the other end of the LC-LC cable into the SFP module, as shown in Figure 35.

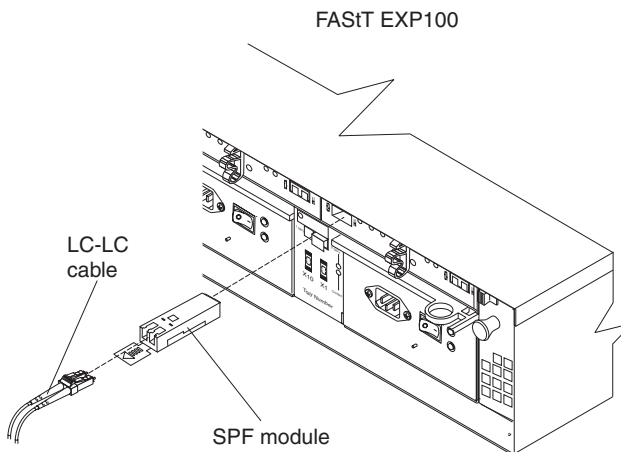

Figure 35. Installing an SFP module and connecting an LC-LC cable to the FASTt EXP100

## FASTt EXP100 loop redundancy

The FASTt EXP100 provides redundant loop support when the second ESM is configured, and when both loops (called A and B) are connected to a FASTt storage server that supports redundant loops. If a cable or SFP module fails on drive loop A, drive loop B provides redundancy, which is an alternate path to your disk drives.

Figure 36 on page 41 shows a redundant loop that you might create with a FASTt600 Storage Server and four FASTt EXP100s. The numbers provided in Figure 36 on page 41 show the order in which cables should be attached.

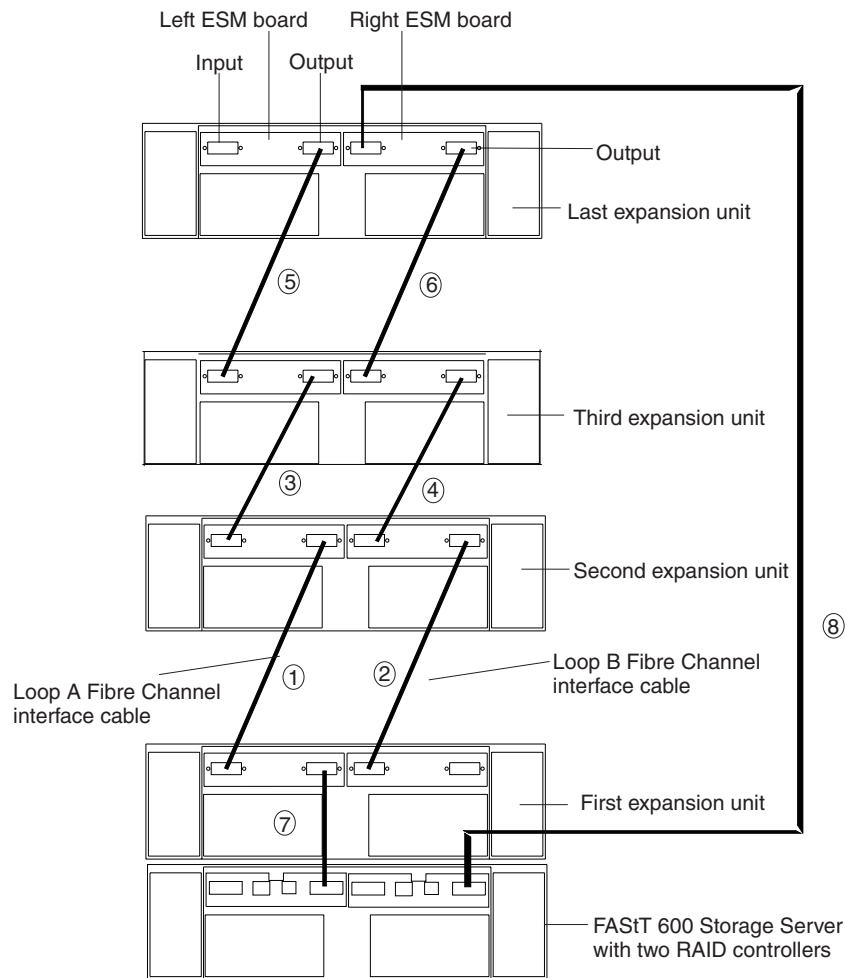

Figure 36. FAST EXP100 redundant loop configuration

To create the redundant loop shown in Figure 36, you would perform the following steps:

1. Make two fibre-channel connections from the *First expansion unit* to the *Second expansion unit* (connections 1 and 2).
2. Make two fibre-channel connections from the *Second expansion unit* to the *Third expansion unit* (connections 3 and 4).
3. Continue making fibre-channel connections in this manner until you have connected all new expansion units (connections 5 and 6 in this case). You can connect up to eight FAST EXP100s together in a redundant drive loop.
4. Make a fibre-channel connection from the FASTt storage server drive port to the **OUT** port in the left ESM of the *First expansion unit* in the redundant drive loop.
5. Make a fibre-channel connection from the FASTt storage server drive port to the **IN** port in the right ESM of the *Last expansion unit* in the redundant drive loop.

IBM SATA disk drives are dual-ported, providing individual access from two fibre-channel loops to the same disk drive. When configuring the ESMs, configure the second ESM the same way that you configured the first ESM. Refer to the *Fibre Channel Cabling Instructions* that come with your storage server for more information about dual-loop support and implementation.

Each ESM has an SFP module input port and an SFP module output port. As you cable FAST EXP100s together, connecting input ports to output ports can improve diagnostic capability. Refer to your storage server documentation and the *Fibre Channel Cabling Instructions* for cabling connections between input and output ports.

## Adding the FAST EXP100 to a loop

You can add up to eight FAST EXP100s to a redundant fibre-channel loop. FAST600 Storage Servers support one redundant drive loop. FAST900 Storage Servers support up to two redundant drive loops. Before you cable your FAST EXP100 to a loop, refer to the *Fibre Channel Cabling Instructions* that come with your storage server for specific instructions.

Figure 37 shows an example of a FAST900 Storage Server configured with four drive loops. Drive loops A and B form one redundant fibre-channel loop. Drive loops C and D form the second redundant fibre-channel loop.

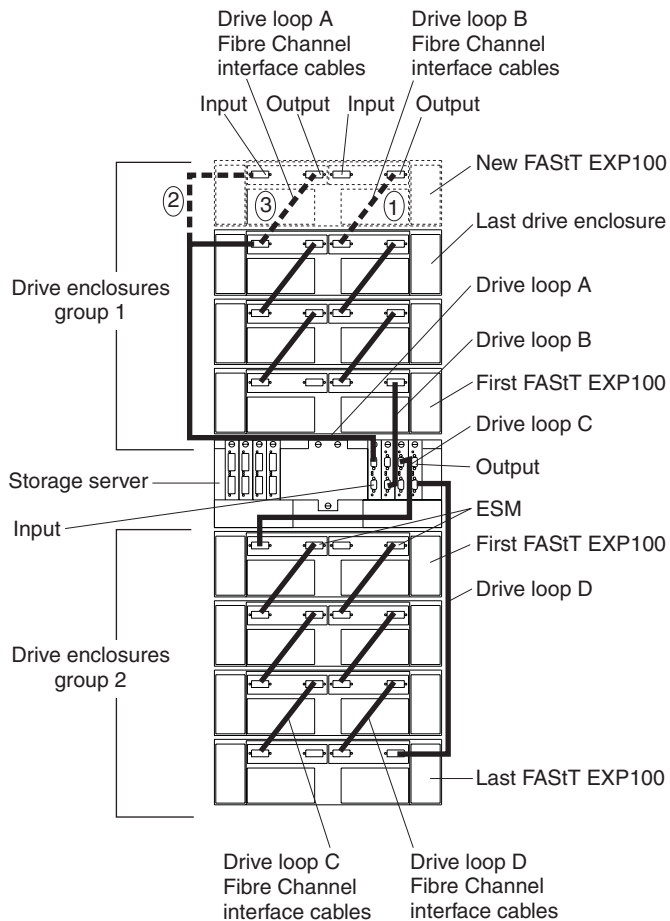

Figure 37. Cabling the FAST EXP100 to two redundant loops

The dashed lines in Figure 37 show how to add a new FAST EXP100 to an existing FAST900 Storage Server configuration with FAST EXP100s. To add the new FAST EXP100 shown in Figure 37, you would perform the following steps:

1. Make the fibre-channel connection marked 1 in Figure 37 (drive loop B). Then power on the new FAST EXP100 and verify that it is recognized by the Storage Manager software GUI.

2. Make the fibre-channel connection marked 2 in Figure 37 on page 42.
3. Make the fibre-channel connection marked 3 in Figure 37 on page 42 (drive loop A).

**Note:** Always add a new FAStT EXP100 to the *end* of a drive loop.

## Cabling the power supply

Complete the following steps to connect the power supply cable:

1. Wrap the strain-relief clamp around the power cable approximately 20 cm (8 in.) from the power supply connection end.
2. Attach the power supply nut and tighten it securely.
3. Connect the power cable to the power supply.
4. Plug the supply power cable into a properly grounded electrical outlet. For maximum protection against power loss, connect each of the two power supplies to a different power source.
5. Continue with “Turning the FAStT EXP100 on and off” for the initial startup of the expansion unit.

---

## Turning the FAStT EXP100 on and off

When you turn on and turn off the FAStT EXP100, be sure to use the startup sequence in this section.

**Attention:** *Before* you first power on the subsystem with a newly installed EXP100, you *must* perform the FAStT controller firmware upgrade described in Appendix A, “Upgrading the FAStT controller firmware,” on page 65.

## Turning on the FAStT EXP100

Use the following startup sequence to turn on the power for the initial startup of the FAStT EXP100:

1. Verify that the following conditions exist:
  - All communication and power cables are plugged into the back of the expansion unit and that all power cables are connected to an ac power outlet.
  - All hard disk drives are locked securely in place.
  - The enclosure IDs on the FAStT EXP100 are set correctly. (See “Setting the interface options” on page 29 for more information.)
2. Check the system documentation for all the hardware devices that you intend to turn on and determine the proper startup sequence. Use the following power-on sequence, where applicable:
  - a. Turn on the power to the supporting devices (for example, Ethernet switches and management stations) before you turn off power to the storage server.
  - b. You must turn on the expansion units before the storage server. The controllers might not recognize the correct configuration if the drives are powered up after the storage server. For instructions on powering up the storage server, see the storage server documentation.
  - c. Turn on the power to the storage server; then restart or turn on the power to the host.

**Note:** Be sure to turn on the FAStT EXP100 before you turn on the FAStT storage server.

In addition, consider the following items:

- The storage subsystem supports simultaneous power-up of the system components; however, you should always follow the power-up sequence listed in the “Turning on the storage server section” of the appropriate *FAStT Storage Server User’s Guide* during any attended power-up procedure.
  - A storage system in an optimal state should recover automatically from an unexpected shutdown and unattended simultaneous restoration of power to system components. After power is restored, contact IBM technical support if any of the following conditions occur:
    - The storage subsystem logical drives and arrays do not display in the Storage Manager graphical user interface (GUI).
    - The storage subsystem logical drives and arrays do not come online.
    - The storage subsystem logical drives and arrays seem to be degraded.
3. Turn on the power to each device, based on the startup sequence.
- Attention:** If you are restarting the system after a normal shutdown, wait at least 10 seconds before you turn on the power supply switches.
4. Turn on both power supply switches on the back of the unit. The FAStT EXP100 might take a few seconds to turn on. During this time, you might see the amber and green LEDs on the FAStT EXP100 flash intermittently. When the startup sequence is complete, only the green LEDs on the front and back light. If other amber LEDs remain lit, see Chapter 4, “Solving problems,” on page 61.

## Turning off the FAStT EXP100

Use this procedure to turn off the power for the FAStT EXP100.

**Attention:** Except in an emergency, never turn off the power if any Fault LEDs are lit on the FAStT EXP100. Correct the fault before you turn off the power, using the proper troubleshooting or servicing procedure. This ensures that the FAStT EXP100 will start correctly later.

Do not turn off the power for the FAStT EXP100 without first turning off the power for the attached FAStT storage server. If you do turn off the power for the FAStT EXP100 before you turn off the power for the attached FAStT storage server, you might lose data access to the configured arrays and logical drives. The FAStT storage server cannot communicate with the drives in powered-off EXP100 units. As a result, it marks these drives as Failed, which in turn might cause the array or logical drive to be placed in Failed state.

The FAStT EXP100 is designed to run continuously. After you turn on the FAStT EXP100, do not turn it off. Turn off the power only in the following situations:

- Instructions in a hardware or software procedure require that you turn off the power.
- An IBM technical support representative instructs you to turn off the power.
- A power outage or emergency situation occurs, see “Restoring power after an emergency” on page 46.

### Statement 5:



#### CAUTION:

The power control button on the device and the power switch on the power supply do not turn off the electrical current supplied to the device. The device also might have more than one power cord. To remove all electrical current from the device, ensure that all power cords are disconnected from the power source.



Complete the following steps to turn off the power:

1. Turn off the power to each device based on the following shutdown sequence:
  - a. Turn off power to the host before you turn off power to the storage server. If the host must stay powered on to support an existing network, see the operating system documentation for information about disconnecting the storage server logical drives from the host before the storage server is powered off.
  - b. Turn off power to the storage server before you turn off power to the FAStT EXP100. Turn off both power supply switches on the back of the storage server.
  - c. Turn off power to other supporting devices (for example, management stations, fibre-channel switches, or Ethernet switches).
2. Make sure that all I/O activity has stopped.
3. Make sure that all amber Fault LEDs are off. If any Fault LEDs light (drives, power supplies, or fans), correct the problem before you turn off the power.

**Note:** Be sure to turn off the FAStT EXP100 after or at the same time as you turn off the storage server.

4. Turn off both power supply switches on the back of the FAStT EXP100.

## Performing an emergency shutdown

**Attention:** Emergency situations might include fire, flood, extreme weather conditions, or other hazardous circumstances. If a power outage or emergency situation occurs, always turn off all power switches on all computing equipment. This helps to safeguard your equipment from potential damage due to electrical surges when power is restored. If the FAStT EXP100 loses power unexpectedly, it might be due to a hardware failure in the power system or in the midplane of the FAStT EXP100.

Complete the following steps to shut down the system during an emergency:

1. Stop all activity and check all of the LEDs. Make a note of any Fault LEDs that are lit so that you can correct the problem when you turn on the power.
2. Turn off all power supply switches; then, unplug the power cables from the FAStT EXP100.

## Restoring power after an emergency

Complete the following steps to restart the FAStT EXP100 if you turned off the power supply switches during an emergency shutdown, or if a power failure or power outage occurred:

1. After the emergency situation is over or power is restored, check the FAStT EXP100 for damage. If there is no visible damage, continue with step 2; otherwise, have your system serviced.
2. After you check the FAStT EXP100 for damage, ensure that the power switches are in the off position; then plug in the FAStT EXP100 power cables.
3. Check the system documentation of the hardware devices that you want to turn on and determine the proper startup sequence.

**Note:** Be sure to turn on the FAStT EXP100 before you turn on the FAStT storage server.

In addition, consider the following items:

- The storage subsystem supports simultaneous power-up of the system components; however, you should always follow the power-up sequence listed in the “Turning on the storage server section” of the appropriate *FAStT Storage Server User’s Guide* during any attended power-up procedure.
  - A storage system in an optimal state should recover automatically from an unexpected shutdown and unattended simultaneous restoration of power to system components. After power is restored, contact IBM technical support if any of the following conditions occur:
    - The storage subsystem logical drives and arrays do not display in the Storage Manager graphical user interface (GUI).
    - The storage subsystem logical drives and arrays do not come online.
    - The storage subsystem logical drives and arrays seem to be degraded.
4. Turn on the power to each device, based on the startup sequence.
  5. Turn on both of the power supply switches on the FAStT EXP100. The green LEDs on the front and the back of the FAStT EXP100 should remain lit. If other amber Fault LEDs light, see Chapter 4, “Solving problems,” on page 61.



---

## Chapter 3. Installing and replacing devices

This chapter contains information about installing and replacing devices.

---

### Working with hot-swap hard disk drives

This section explains how you can increase the expansion unit capacity by adding more hard disk drives or by replacing existing drives with ones that have a larger capacity. Before you begin, complete the following tasks:

- Read the safety and handling guidelines in “Safety” on page iii and in “Handling static-sensitive devices” on page 16.
- Ensure that your current system configuration is working properly.
- Back up all important data before you make changes to data storage devices.

Before you install or remove drive CRUs, review the following information:

- **Blank trays:** An expansion unit without a full set of drives (14) contains blank trays in the unused drive bays. Before installing new drives, you must remove these empty trays. Save the empty trays for future use. Each of the 14 bays must always contain either a blank tray or a hot-swap hard disk drive.

**Note:** For proper cooling and EMC protection, do not leave a drive slot open without either a drive blank or a drive CRU inserted.

- **Drive CRUs:** The FAStT EXP100 supports IBM 1.5 Gbps SATA hard disk drives.

**Note:** Do not use fibre-channel hard disk drive CRUs in the FAStT EXP100.

- **Drive CRU labels:** A label is provided on the front of each hard disk drive. Use this label to record the location information for each drive before you remove it. Ensure that you keep track of the drives and their corresponding bays. Also, record the location information in Table 11 on page 77. If you install a drive in the wrong bay, you might lose data.
- **Drive LEDs:** Each drive tray has two associated LEDs, a green Activity LED and an amber Fault LED, on the chassis of the FAStT EXP100. These LEDs indicate the status for that drive. See Table 9 for the drive LED states and descriptions.

Table 9. Drive LED activity

LED	LED state	Descriptions
Activity LED	Flashing green	The green LED flashes to indicate fibre-channel activity to the drive.
Activity LED	Steady green	The green LED lights to indicate that the drive is properly installed and is spun up by the FAStT controller.
Fault LED	Flashing amber	The amber LED flashes to indicate that a drive has been identified by the software.
Fault LED	Steady amber	The amber LED lights to indicate a drive failure.
Activity and Fault LEDs	All unlit	Check for and resolve one of the following situations: <ul style="list-style-type: none"><li>• FAStT EXP100 is turned off</li><li>• FAStT EXP100 is not connected to the FAStT storage server</li><li>• FAStT storage server does not have the correct firmware version</li></ul>

- **Fibre-channel loop IDs:** When you install a hard disk drive in the expansion unit, the drive tray connects into a printed circuit board called the *midplane*. The midplane sets the fibre-channel loop ID automatically, based on the setting of the enclosure ID switch and the physical location (bay) of the drive CRU.
- **Hot-swap hardware:** The FAST EXP100 contains hardware that enables you to replace a failed hard disk drive without turning off the expansion unit. You can continue to operate your system while a hard disk drive is removed or installed. These drives are known as hot-swap hard disk drives.

## Installing hot-swap hard disk drives

You can install hard disk drives while the expansion unit is turned on and running. Complete the following steps to install hot-swap hard disk drives in the expansion unit:

1. Read the documentation that comes with the hard disk drive.
2. Check for Fault LEDs shown in Figure 38. If any amber LEDs are lit, see Chapter 4, “Solving problems,” on page 61.

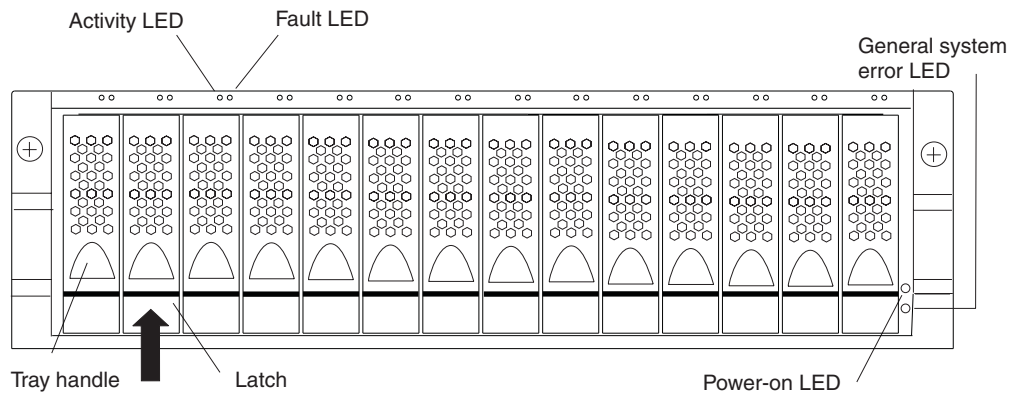

Figure 38. Hot-swap hard disk drive LEDs

3. Determine the bay into which you want to install the drive.
4. Remove the blank tray:
  - a. Release the latch on the drive CRU by pinching together the blue line on the tray latch and the finger hole on the tray handle, as shown by the arrow in Figure 38.
  - b. Pull the handle on the tray out so that it is in the open position to release the drive CRU, and then pull the blank tray out of the bay.
  - c. Save the blank tray for later use.
5. Install the hard disk drive:

**Note:** The hard disk drive comes installed in a drive tray. Do not attempt to detach the drive from the tray.

- a. Release the latch on the drive CRU by pinching together the blue line on the tray latch and the finger hole on the tray handle.

- b. Pull the handle on the tray out so that it is in the open position, as shown in Figure 39.

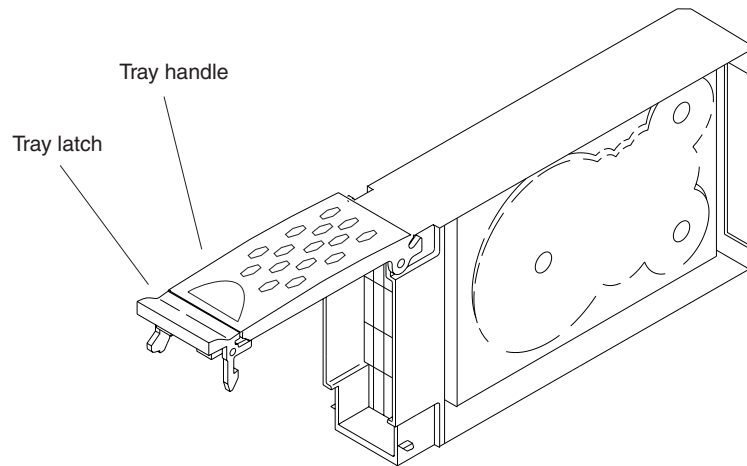

Figure 39. Drive CRU handle

- c. Slide the drive CRU into the empty bay until the hinge of the tray handle latches beneath the expansion unit bezel.
- d. Push the tray handle down until it latches into place.

## Replacing hot-swap hard disk drives

Drive problems include any malfunctions that delay, interrupt, or prevent successful I/O activity between the hosts and the hard disk drives in the expansion unit. This includes transmission problems between the host controllers, the ESMS, and the drives. This section explains how to replace a failed hard disk drive.

**Note:** If you want to remove a hard disk drive that is not in a failed or bypass state, always use the Storage Manager client program either to place the drive in a failed state or to place the array that is associated with the drive (or drives) in an offline state before you remove the drive from the enclosure.

**Attention:** Failure to replace the hard disk drives in their correct bays might result in loss of data. If you are replacing a hard disk drive that is part of a configured array and logical drive, ensure that you install the replacement hard disk drive in the correct bay. Check the hardware and software documentation that is provided with your FAST storage server to see if there are restrictions regarding hard disk drive configurations.

Complete the following steps to replace a hot-swap hard disk drive:

1. Determine the location of the drive that you want to remove.  
**Attention:** Never hot-swap a drive CRU when its associated green Activity LED is flashing. Hot-swap a drive CRU only when its associated amber Fault LED is lit and not flashing.
2. Remove the drive CRU:
  - a. Release the latch on the drive CRU by pinching together the blue line on the tray latch and the finger hole on the tray handle, as shown by the arrow in Figure 39.
  - b. Pull the tray handle out into the open position.
  - c. Lift the drive CRU partially out of the bay.

- d. To avoid possible damage to the drive, wait at least 20 seconds before fully removing the drive CRU from the expansion unit to allow the drive to stop (spin down).
  - e. Verify that there is proper identification (such as a label) on the drive CRU, and then slide it completely out of the expansion unit.
3. Install the new drive CRU:
    - a. Gently push the drive CRU into the empty bay until the hinge of the tray handle latches beneath the expansion unit bezel.
    - b. Push the tray handle down into the closed (latched) position.
  4. Check the drive LEDs:
    - When a drive is ready for use, the green Activity LED lights and the amber Fault LED is off.
    - If the amber Fault LED lights and is not flashing, remove the drive from the unit and wait 10 seconds; then, install the drive again.
  5. Use the Storage Manager software GUI to verify that the drive is shown in the Storage Subsystem Management window.

## Replacing multiple drives

This section provides guidelines for upgrading the drives in the expansion unit. Read the software documentation and this entire section to determine if you should use this procedure, use a modified version of this procedure, or use a different procedure that is provided by your operating system. *Instructions that are provided with your software should supersede anything stated in this document.*

There are two methods for upgrading drives:

- **Replacing all the drives at the same time**

This method requires that you back up the data on the affected drives and then turn off the FASTT EXP100 and the FASTT storage server.

**Attention:** Turn off the FASTT storage server before you turn off the FASTT EXP100.

After replacing all the drives, you must reconfigure the new drives and restore data from backup. See the procedure in “Replacing all drives at the same time” on page 51.

This is the safest way to exchange drives without losing data. However, this method might take a long time to complete because of the backup, reconfiguration, and restoration processes. In addition, other users are not able to use the storage server (or any expansion units attached to the storage server) until you finish the procedure. You must use this method on RAID 0 logical drives.

- **Replacing the drives one at a time**

In this method, you manually fail each drive, replace it, and wait for the system to restore data to the new drive before installing the next drive. After you install the new drives, you can configure them to make the additional drive space available. See the procedure in “Replacing the drives one at a time” on page 53.

Using this method, you can replace the drives while the FASTT EXP100 and the FASTT storage server are running, eliminating the down time that is required if you replace all the drives at once. However, this method is more risky because you can lose data if the drive restoration or storage subsystem reconfiguration process fails. In addition, the reconstruction process might take a long time. This method works only on redundant logical drives (RAID 1, 3, or 5). You cannot use this method with any drives containing RAID 0 logical drives.

Consider backing up your data if you use this method. This safeguards your data if the restoration and reconfiguration process fails or the new drive malfunctions.

The method you use depends on the following considerations:

- Which method most closely matches the recommended drive upgrade procedure that is provided in the operating system or the storage-management software documentation
- Which RAID level is used on the affected drives (RAID 0 requires you to replace all the drives at the same time)
- How much downtime is acceptable as you swap the drives
- The number of drives in an array. Replacing drives one at a time is better suited for arrays consisting of 3 to 5 drives. If you have more than 10 drives, consider replacing all drives at the same time.

### **Replacing all drives at the same time**

Use this procedure to replace all drives at the same time. You must use this method if you are upgrading drives containing RAID 0 logical drives. All the data currently on the drives is lost when you replace the drives; therefore, you must back up all data that is currently on the drives. This procedure also requires you to turn off the FAStT EXP100 and the FAStT storage server, which makes the storage server (and any attached expansion units) inaccessible to other users.

To replace all the drives at the same time, perform the following steps:

1. Read the following information:

- The information in “Replacing multiple drives” on page 50, particularly the paragraphs that discuss the differences between the two possible upgrade procedures
- The information in your software documentation regarding drive upgrades and installation
- The documentation that comes with the new drives

Read all precautionary notes, kit instructions, and other information. Kit instructions often contain the most current information regarding the drives and their installation, plus upgrade or servicing procedures. Compare the kit instructions with this procedure to determine if you need to modify this procedure.

2. Use the FAStT Storage Manager software to check the status of the FAStT storage server. Correct any problems that are reported.

3. Perform a complete backup of the drives that you are replacing.

You need the backup to restore data on the drives later in this procedure.

**Attention:** When you handle static-sensitive devices, take precautions to avoid damage from static electricity. For details about handling static-sensitive devices, see “Handling static-sensitive devices” on page 16.

4. Unpack the new drives.

Set the drives on a dry, level surface away from magnetic fields. Save the packing material and documentation in case you need to return the drives.

5. Perform the following steps:

- a. Stop all I/O activity to the storage server and attached expansion units. Make sure that:

- 1) All of the green Drive activity LEDs on the front of the storage server (and on all attached FAStT EXP100s) are not flashing.

- 2) The green Cache active LEDs are off. Depending on the model, the cache active LEDs are either in the front (FAStT900) or the back (FAStT600) of the storage server.
- b. If applicable, use the operating system software to disconnect the storage server logical drives from the host before you power off the storage server.

**Attention:** To turn off all power to the storage server, you must turn off both power-supply switches and disconnect both power cords. Use the procedure in step 6 for the proper shutdown sequence.

6. Turn off the power to each device based on the following shutdown sequence:
  - a. Turn off power to the host before you turn off power to the storage server. If the host must stay powered on to support an existing network, see the operating system documentation for information about disconnecting the storage server logical drives from the host before the storage server is powered off.
  - b. Turn off power to the storage server before you turn off power to the FAStT EXP100. Turn off both power supply switches on the back of the storage server.
  - c. Turn off power to other supporting devices (for example, management stations, fibre-channel switches, or Ethernet switches).
7. Use the procedures in “Replacing hot-swap hard disk drives” on page 49 to remove the drives that you want to replace. Use the procedures in “Installing hot-swap hard disk drives” on page 48 to install the new drives into the FAStT EXP100.
8. After you install all the new drives, check the system documentation for the hardware devices that you intend to power up, and then determine the proper startup sequence. Use the following power-on sequence, where applicable:
  - a. Turn on the power to the supporting devices (for example, Ethernet switches and management stations) before you turn off power to the storage server.
  - b. You must turn on the expansion units before the storage server. The controllers might not recognize the correct configuration if the drives are powered up after the storage server. For instructions on powering up the storage server, see the storage server documentation.
  - c. Turn on the power to the storage server; then restart or turn on the power to the host.
9. Turn on the power to each device, based on the power-on sequence in step 8. To turn on power to the storage server and the FAStT EXP100s, turn on the power-supply switches on the back of the storage server. You must turn on both power-supply switches to take advantage of the redundant power supplies.
10. Check the green Drive activity LEDs and the amber Drive fault LEDs above the new drive CRUs.

Make sure that the Drive activity LEDs are on and the Drive fault LEDs are off.

**Note:** The Drive fault LEDs might flash intermittently while the drives spin up.

- If the Drive activity LED is off, the drive CRU might not be installed correctly. Remove the drive CRU, wait 30 seconds, and then reinstall it.
- If the Drive fault LED stays on or the Drive activity LED stays off, the new drive might be faulty. See the FAStT Storage Manager software for problem determination.

11. Use the FAST Storage Manager software to configure the new drives. See the FAST Storage Manager software online Help for detailed instructions.
12. Restore the data from backup to all the drives.

### Replacing the drives one at a time

Use this procedure to replace all the drives one at a time. You cannot use this procedure on RAID 0 logical drives (use the procedure in “Replacing all drives at the same time” on page 51).

**Note:** If your storage subsystem has hot spares assigned, you might want to unassign the hot spares while you perform this procedure. If you do not, reconstruction might start on the hot spare before you insert the new drive. The data on the new drive is still rebuilt, but the process takes longer for each drive. Remember to reassign the hot spares when you are finished with this procedure.

To replace the drives one at a time, perform the following steps:

1. Read the following information:
  - “Replacing multiple drives” on page 50, particularly the paragraphs that discuss the differences between the two possible upgrade procedures
  - Your software documentation regarding drive upgrades and installation
  - The documentation that comes with the new drivesRead all precautionary notes, kit instructions, and other information. Kit instructions often contain the most current information regarding the drives and their installation, plus upgrade or servicing procedures. Compare the kit instructions with this procedure to determine if you need to modify this procedure.
2. Use the FAST Storage Manager software to check the status of the unit. Correct any problems that are reported.
3. Back up the data in the arrays and logical drives that are configured using the drives that you are replacing.

**Attention:** When you handle static-sensitive devices, take precautions to avoid damage from static electricity. For details about handling static-sensitive devices, see “Handling static-sensitive devices” on page 16.

4. Unpack the new drives.

Set the drives on a dry, level surface away from magnetic fields. Save the packing material and documentation in case you need to return the drives.
5. Use the FAST Storage Manager software to ensure that the array that was defined using these drives is in optimal (not degraded) state before manually failing the first drive you want to replace. If the array is in degraded state, use the recovery procedures to bring the array into the optimal state.

Make sure that:

- You fail only one drive
- The software status display shows a failed status for the appropriate drive
- The amber Drive fault LED (on the front bezel below the drive) is on



**Attention:** Removing the wrong drive can cause data loss. Make sure that you remove only the failed drive CRU. The Drive fault LED below the failed drive CRU should be on.

If you remove an active drive accidentally, wait at least 30 seconds and then reinstall it. Because you failed two drives in a RAID array, the array might be marked failed by the controller. This array will not be available to the host for I/O. See the FAStT Storage Manager software for further recovery instructions. Do not attempt to replace any drives until the array is brought back to optimal state.

6. Use the procedures in “Replacing hot-swap hard disk drives” on page 49 to remove the failed drive. Use the procedures in “Installing hot-swap hard disk drives” on page 48 to install the new drives into the FAStT EXP100.

The new drive automatically reconstructs the data after you install it in the drive slot.

During data reconstruction, the amber Drive fault LED might come on for a few minutes, then turn off when the green Drive activity LED begins flashing. A flashing Drive activity LED indicates that data reconstruction is in progress.

**Note:** If your storage subsystem has active hot spares, data might not start copying to the new drive until the data is reconstructed on the hot spare. This increases the time that is required to complete the procedure.

7. Check the green Drive activity LED and the amber Drive fault LED above the new drive CRUs.

Make sure that the Drive activity LEDs are on and the Drive fault LEDs are off.

**Note:** The Drive fault LEDs might flash intermittently while the drives spin up.

- If the Drive activity LED is off, the drive CRU might not be installed correctly. Remove the drive CRU, wait 30 seconds, and then reinstall it.
- If the Drive fault LED stays on or the Drive activity LED stays off, the new drive might be faulty. See the FAStT Storage Manager software for problem determination.

8. Use the FAStT Storage Manager software to monitor the status of the new drive and the progress of the data reconstruction. Wait for data reconstruction to finish (the Drive activity LED stops flashing).

**Note:** The Drive activity LED will continue to flash after reconstruction is finished if there is I/O activity to that drive. In that case, use the host software to determine if the data reconstruction is finished.

9. When reconstruction is finished on the new drive, repeat step 5 on page 53 through step 8 for each additional drive that you want to install.
10. Use the FAStT Storage Manager software to configure the additional space on the new drives.

---

## Working with hot-swap power supplies

The power supplies are CRUs and do not require preventive maintenance.

- Use only the supported power supplies for your specific expansion unit.
- Both power supplies must always be installed to maintain proper cooling and to protect against power loss.



**Statement 8:**



**CAUTION:**

Never remove the cover on a power supply or any part that has the following label attached.



Hazardous voltage, current, and energy levels are present inside any component that has this label attached. There are no serviceable parts inside these components. If you suspect a problem with one of these parts, contact a service technician.

## Removing the failed hot-swap power supply

Complete the following steps to remove the failed hot-swap power supply:

1. Turn the power supply switch to the off position.
2. Unplug the power supply cable from the electrical outlet.
3. Disconnect the power cable from the power supply ac connector.
4. Remove the nut and clamp from the rear of the power supply.
5. Remove the power supply from the expansion unit:
  - a. Grasp the pull-ring on the power supply lever and squeeze the latch to release it.
  - b. Pull the lever open and remove the power supply.

## Replacing the failed hot-swap power supply

This section describes the procedure for replacing the failed hot-swap power supply.

**Note:** Before you replace the failed power supply, ensure that the new power supply lever is attached to the side of the power supply that faces the middle of the expansion unit. If it is not, remove the lever screw, flip the lever over, and tighten the screw on the opposite side as shown in Figure 40 on page 56.

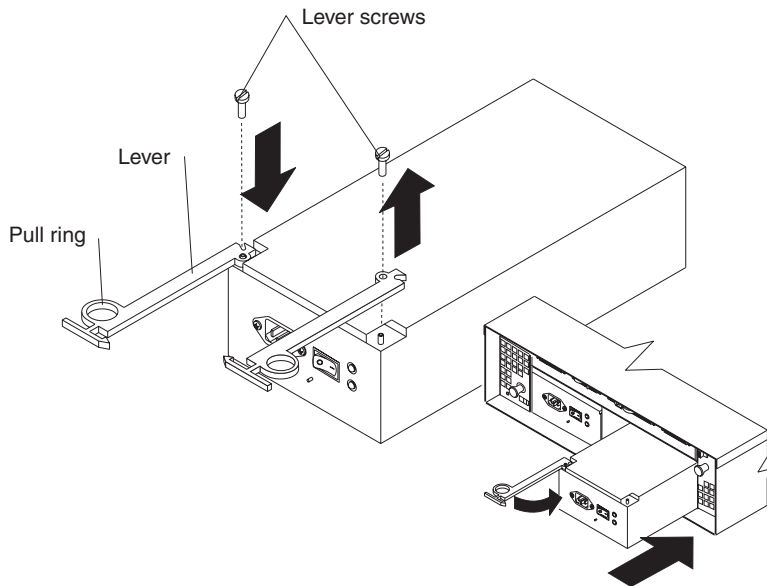

Figure 40. Moving the power supply lever and replacing the failed hot-swap power supply

Complete the following steps to replace the failed hot-swap power supply:

**Statement 8:**



**CAUTION:**

Never remove the cover on a power supply or any part that has the following label attached.



**Hazardous voltage, current, and energy levels are present inside any component that has this label attached. There are no serviceable parts inside these components. If you suspect a problem with one of these parts, contact a service technician.**

1. Ensure that the ac power switch on the power supply that you are installing is in the off position.
2. Install the power supply in the expansion unit:
  - a. Slide the power supply into the expansion unit. Be sure that the lever is pulled straight out as you slide the power supply into the expansion unit (see Figure 40).
  - b. Close the lever until the pull-ring latch locks in place. Make sure that the lever locks into place in the expansion unit chassis.
3. Wrap the strain relief clamp around the power cable approximately 20 cm (8 in.) from the power supply connection end.

4. Attach the power supply nut and tighten it securely.
5. Connect the power cable to the power supply ac connector. See Figure 41.

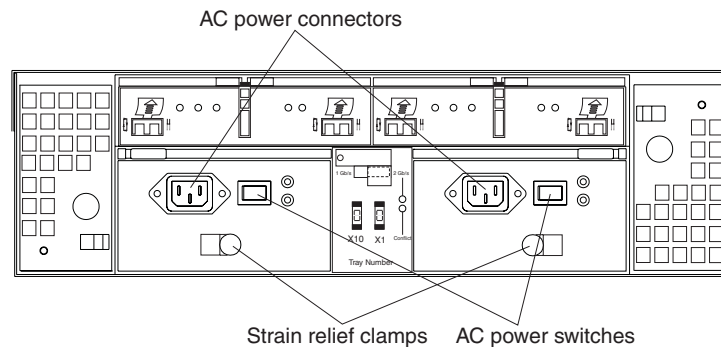

Figure 41. Connecting the power supply

6. Plug the supply power cable into a properly grounded electrical outlet.
7. Turn the power supply switch to the on position.

---

## Replacing a failed hot-swap ESM

This section describes the removal and replacement procedure for a failed hot-swap ESM. Complete the following steps to remove a failed ESM:

1. Check the storage management software online help for ESM failure-recovery procedures. Follow the steps provided in the failure-recovery procedures before continuing to step 2.
2. Label each cable to ensure that all cables are properly connected to the new ESM.
3. Label the SFP modules when you remove them. You must install the SFP modules in the same positions on the new ESM.
4. Remove the SFP modules and the fibre-channel cables from the failed ESM.

**Attention:** Be careful not to bend the fibre-channel cables at a sharp angle or pinch them with objects. This can decrease the performance or cause data loss.

5. Be sure that the Fault LED is lit; then, push down on the ESM latch. While holding down the ESM latch, grasp the pull rings and pull out on the levers to disconnect the ESM from the FAST EXP100 midplane. The ESM levers will pop out of the locked position, as shown in Figure 42 on page 58.

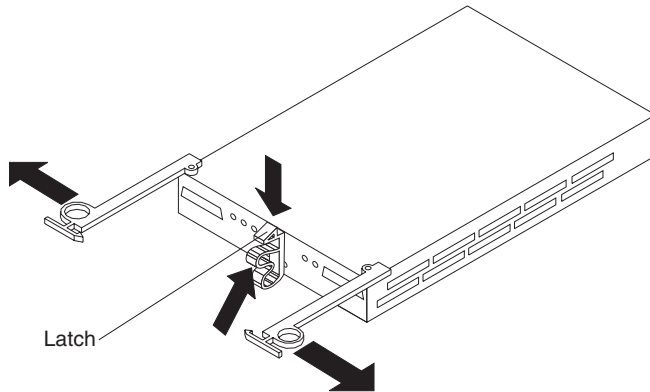

Figure 42. Removing the failed ESM

6. Remove the ESM.
7. Install the new ESM by sliding it into the empty slot. Be sure that the levers are pulled straight out as you slide the ESM into the expansion unit. When you install the ESM into the bays, the ESM latch locks into place.
8. Close the levers until the pull-ring latch locks in place. Make sure that the levers lock into place in the expansion unit chassis.
9. Reconnect the SFP modules and the fibre-channel cables to their original locations.
10. Check the input and output bypass LEDs at both ends of the reconnected cables. If the input and output bypass LEDs are lit, reconnect the cables and SFP modules.
11. Check the Power and Fault LEDs on the new ESM:
  - If the Power LED is off, the ESM might not be inserted correctly.
  - If the Fault LED lights, if the Power LED is off, or if any other Fault LEDs are lit, see Chapter 4, “Solving problems,” on page 61.
12. See your storage management software online help for instructions for enabling the ESM.

---

## Replacing a failed hot-swap cooling fan

**Attention:** Do not run the expansion unit without adequate ventilation and cooling. Improper ventilation might cause damage to the internal components and circuitry.

The fans are interchangeable and replaceable, and do not require preventive maintenance. The fans help maintain proper air circulation across the components inside the expansion unit. Air flows through the expansion unit from the front to the back.

You can hot-swap the fans, provided that you complete the exchange within 10 minutes. This time limit applies only to the total time that a fan is out of the expansion unit, beginning when you remove the failed unit and ending when you reseal the new one. This does not include the time it takes you to perform this entire procedure (checking LEDs, unpacking the new fan, and so on).

For any period of time exceeding 10 minutes, both fan units must always be in place, even if one is not functioning properly. This is necessary to maintain proper cooling.

Complete the following steps to replace a hot-swap fan:

1. Check the LEDs on the back of the expansion unit.
2. If the fan amber Fault LED is lit, remove the failed fan:
  - a. Slide the latch in the same direction as the arrow to unlock the fan.
  - b. Use the handle (black knob) to pull the fan from the fan bay, as shown in Figure 43.

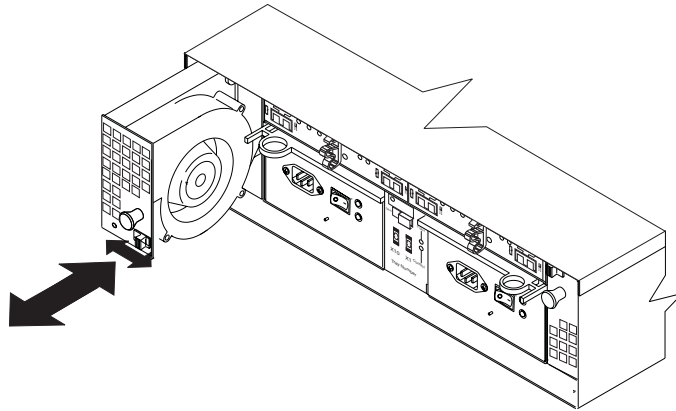

Figure 43. Replacing a hot-swap cooling fan

3. Install the new fan:
  - a. Place the fan in front of the fan bay.
  - b. Ensure that you move the latch in the same direction as the arrow before you slide the fan all the way into the bay. If the fan does not go into the bay, rotate it 180°.
  - c. If the latch does not automatically lock when you have successfully inserted the fan unit into the bay, pull back on the fan slightly, and then push it in again until the latch snaps into place.
4. Check the LEDs.
5. The Fault LEDs are no longer lit after a few seconds; if they remain on, see Chapter 4, “Solving problems,” on page 61.



## Chapter 4. Solving problems

This chapter contains information to help you solve some of the problems you might have with your expansion unit. Table 10 contains the problem symptoms and error messages, along with suggested actions to take to resolve problems.

Table 10. Solving problems

Problem indicator	Component	Possible cause	Possible solutions
Amber LED is lit	Drive CRU	Drive failure	Replace the failed drive.
	Fan CRU	Fan failure	Replace the failed fan.
	ESM over-temperature LED	Subsystem has overheated	Check fans for faults. Replace the failed fan if necessary.
		Environment is too hot	Check the ambient temperature around the expansion unit. Cool as necessary.
		Defective LED or hardware failure	If you cannot detect a fan failure or overheating problem, replace the ESM.
	ESM Fault LED	ESM failure	Replace the ESM. See your controller documentation for more information.
	ESM Bypass LED	No incoming signal detected	Reconnect the SFP modules and the fibre-channel cables. Replace input and output SFP modules or cables as necessary.
		ESM failure	If the ESM Fault LED is lit, also replace the ESM.
	Front panel	General machine fault	A Fault LED is lit somewhere on the expansion unit (check for Amber LEDs on CRUs).
Fibre-channel connection failure		Check that the CRUs are properly installed. If none of the amber LEDs are lit on any of the CRUs, this indicates an SFP module transmission fault in the expansion unit. Replace the failed SFP module. See your storage manager software documentation for more information.	
ESM ID conflict	This enclosure has the same ID as one of the other enclosures or storage servers in the drive loops.	Change the enclosure ID switches to set a unique ID for this enclosure.	
Amber LED is lit and green LED is off	Power supply CRU	The power switch is turned off or there is an ac power failure.	Replace the failed power supply or turn on all power supply switches.
Amber and green LEDs are lit	Power supply CRU	Power supply failure	Replace the failed power supply.

Table 10. Solving problems (continued)

<b>Problem indicator</b>	<b>Component</b>	<b>Possible cause</b>	<b>Possible solutions</b>
All amber and green LEDs are off	All drive CRUs	Check for and resolve one of the following situations: <ul style="list-style-type: none"> <li>• FAStT EXP100 is turned off</li> <li>• FAStT EXP100 is not connected to the FAStT storage server</li> <li>• FAStT storage server does not have the correct firmware version</li> </ul>	
All green LEDs are off	All CRUs	Subsystem power is off	Check that all expansion unit power cables are plugged in and the power switches are on. If applicable, check that the main circuit breakers for the rack are powered on.
		AC power failure	Check the main circuit breaker and ac outlet.
		Power supply failure	Replace the power supply.
		Midplane failure	Contact an IBM technical support representative to service the expansion unit.
Amber LED is flashing	Drive CRUs	Drive identity is in process	No corrective action needed.
	ESM port bypass	An FC loop initialization process (LIP) is being generated in the drive loop due to a faulty component.	Use the Read Link Status window in the Storage Manager Client Subsystem Management window and the storage subsystem event logs to isolate the faulty component.



Table 10. Solving problems (continued)

Problem indicator	Component	Possible cause	Possible solutions
One or more green LEDs are off	Power supply CRUs	Power cable is unplugged or switches are turned off	Make sure that the power cable is plugged in and that the switches are turned on.
	All drive CRUs	Midplane failure	Replace the midplane. Contact an IBM technical support representative.
	Several CRUs	Hardware failure	Replace the affected CRUs. If this does not correct the problem, replace the ESMs, followed by the midplane. Contact an IBM technical support representative.
		The FASTt storage server was not powered on, or all fibre-channel connections between the EXP100 and the storage server failed.	Perform one of the following actions: <ul style="list-style-type: none"> <li>• Power on the storage server.</li> <li>• Verify that the fibre-channel connections between the EXP100 and the storage server are made.</li> </ul>
	Front panel	Power supply problem	Make sure that the power cables are plugged in and that the power supplies are turned on.
Hardware failure		If any other LEDs are lit, replace the midplane. Contact an IBM technical support representative.	
Intermittent or sporadic power loss to the expansion unit	Some or all CRUs	Defective ac power source or improperly connected power cable	Check the ac power source. Reseat all installed power cables and power supplies. If applicable, check the power components (power units or universal power supply). Replace defective power cables.
		Power supply failure	Check the power supply Fault LED on the power supply. If the LED is lit, replace the failed CRU.
		Midplane failure	Have the midplane replaced. Contact an IBM technical support representative.
Unable to access drives	Drives and fibre-channel loop	Incorrect expansion unit ID settings	Ensure that the fibre-channel optical cables are undamaged and properly connected. Check the expansion unit ID settings. <b>Note:</b> Change the switch position only when your expansion unit is powered off.
		ESM failure	Replace one or both ESMs. Contact an IBM technical support representative.
		Drive or drives failed	Replace failed drive or drives.

Table 10. Solving problems (continued)

<b>Problem indicator</b>	<b>Component</b>	<b>Possible cause</b>	<b>Possible solutions</b>
Random errors	Subsystem	Midplane failure	Have the midplane replaced. Contact an IBM technical support representative.

---

## Appendix A. Upgrading the FAStT controller firmware

FAStT EXP100 support requires that you upgrade any connected FAStT600 or FAStT900 Storage Servers with FAStT controller firmware and NVSRAM level 5.41.xx.xx. If you did not order your FAStT storage server from the factory with firmware level 5.41.xx.xx installed, you must upgrade the controller firmware manually from firmware level 5.40.xx.xx or earlier.

FAStT controller firmware 5.41.xx.xx is shipped with the FAStT EXP100 on the *FAStT Storage Manager V8.41 Support for FAStT EXP100 SATA Storage Expansion Unit* CD. To download the latest FAStT storage server controller firmware and NVSRAM 5.41.xx.xx, go to the following Web site:

[www.ibm.com/storage/support/fastt](http://www.ibm.com/storage/support/fastt)

### Attention

It is essential that you review and understand the following issues *before* you upgrade the FAStT storage server controller firmware to version 5.41.xx.xx in order to support the FAStT EXP100:

1. After you upgrade the FAStT storage server with controller firmware 5.41.xx.xx, *you cannot downgrade the firmware to an earlier level.*
2. After you upgrade the FAStT storage server with controller firmware 5.41.xx.xx, *FAStT600 and FAStT900 Storage Servers will not be able to attach to fibre-channel expansion unit enclosures such as FAStT EXP500 or EXP700, even when these enclosures are not part of the same drive loop or loops as the EXP100s. You must disconnect any FAStT EXP500 or EXP700 enclosures from the FAStT storage server before you upgrade the controller firmware to version 5.41.xx.xx.*

**Note:** IBM plans to enable the concurrent attachment of both the FAStT EXP100 SATA disk drive enclosure and the FAStT EXP700 Fibre Channel disk drive enclosure to a FAStT600 or FAStT900 Storage Server in future releases of the FAStT storage server firmware and FAStT Storage Manager host software.

3. After you upgrade the FAStT storage server with controller firmware 5.41.xx.xx, *FAStT600 Storage Servers will not be able to use fibre-channel drives within the controller enclosure.*

A FAStT600 Storage Server with controller firmware 5.41.xx.xx installed will not support any fibre-channel hard disk drives (FC HDDs) in the FAStT600 drive slots. You must remove any FC HDDs that are installed in these drive slots and replace them with drive blanks.

Use the following procedure to upgrade a FAStT Storage Server manually to controller firmware level 5.41.xx.xx:

**Attention:** This procedure requires the out-of-band (Ethernet) management connections to both controllers in the connected FAStT storage server. You can define the controller TCP/IP addresses in the following three ways:

- By default (to 192.168.128.101 and 192.168.128.102 for Controllers A and B respectively)
- By a DHCP/BootP server
- By static definition. Existing FAStT controllers have stored TCP/IP addresses that can be used for static definition.

Refer to the *FAStT Storage Manager 8.4x Installation and Support Guide* for your operating system for more information.

1. In accordance with the previously described issues, verify that the following conditions exist:
  - The FAStT600 or FAStT900 Storage Server and FAStT EXP100 drive expansion enclosures are installed properly in the rack.
  - The FAStT EXP100 is not connected to any FAStT storage servers that are also connected to EXP700 or EXP500 drive expansion enclosures.
  - If the FAStT EXP100 is connected to a FAStT600 Storage Server, the FAStT600 Storage Server does not use any fibre-channel drives within the controller enclosure.
2. With the FAStT storage server and the FAStT EXP100s powered off, establish all fibre-channel cabling connections. See “Cabling the FAStT EXP100” on page 31.
3. Install FAStT Storage Manager client software version 8.41 in the management station. Refer to the *IBM TotalStorage FAStT Storage Manager 8.4x Installation and Support Guide for Intel-based Operating System Environments* or the *IBM TotalStorage FAStT Storage Manager 8.4x Installation and Support Guide for AIX, UNIX, and Solaris*.

**Attention:** The management station must have an Ethernet connection to the same network as the two controllers in the FAStT storage server.

4. Remove Controller A from the FAStT storage server.

**Note:** For the FAStT900, Controller A is the top controller when looking at the front of the unit. For the FAStT600, Controller A is the left controller when looking at the back of the unit.

5. Power on the FAStT storage server only.
6. Add Controller B to the Enterprise Management window of the FAStT Storage Manager client program.

In the Enterprise Management Window, click **Edit -> Add Device**. Enter the TCP/IP address of Controller B and click **Add** when the Add Device window opens.

7. Click **Close** to close the Add Device window.

**Note:** A Partially Managed Devices window might open, warning that you have not added the second controller of the FAStT storage server controller pairs. Click **Close** to close this window.

8. In the Enterprise Management window, right-click the entry for Controller B (which you just added) and select **Manage Device** from the pop-up menu.

**Note:** A Partially Managed Notice window might open, warning you that the storage subsystem that you are trying to manage has a controller that

has not yet been added to the Enterprise Management window. Click **Yes** to launch the Subsystem Management window for this FAStT controller anyway.

9. The Subsystem Management window opens. Click **Storage Subsystem → Download → Firmware** to open the FAStT Firmware Download window. Select the appropriate 05.41.xx.xx firmware file and click **OK** to start the download.
10. One of two windows displays:
  - If you receive the message *Firmware download is completed* and the *New Firmware Detected* window displays, then continue with step 11.
  - If you receive a *Controller Download Timeout* error, power off and then power on the FAStT storage server. Then verify that the firmware was downloaded correctly to Controller B of the storage server. (To verify that the correct firmware version was downloaded, right-click the Controller B icon in the Physical pane of the Subsystem Management window and select **Properties**.)
    - If the firmware was downloaded correctly, continue with step 12.
    - If the firmware was not downloaded correctly, try the firmware download again. If the problem persists after the second storage server power-cycle, call your IBM technical support representative.
11. Click **OK** to close the *New Firmware Detected* window and the Subsystem Management window. In the Enterprise Management window, right-click the entry for Controller B and select **Manage Device** from the pop-up menu. The Subsystem Management window opens.
12. In the Subsystem Management window, click **Storage Subsystem → Download → NVSRAM** to load the NVSRAM file to Controller B.
13. One of two windows displays:
  - If you receive the message *NVSRAM download is completed*, then continue with step 14.
  - If you receive a *Controller Download Timeout* error, power off and then power on the FAStT storage server. Then verify that the NVSRAM was downloaded correctly to Controller B of the storage server. (To verify that the correct NVSRAM version was downloaded, click **View → Storage Subsystem Profile**. In the Storage Subsystem Profile window, look for the correct NVSRAM file version under the All tab.)
    - If the NVSRAM was downloaded correctly, continue with step 15.
    - If the NVSRAM was not downloaded correctly, try the NVSRAM download again. If the problem persists after the second storage server power-cycle, call your IBM technical support representative.
14. Close the Subsystem Management window. In the Enterprise Management window, remove the Controller B entry from the Directly-Managed Storage Subsystem list.
15. Power off the FAStT storage server.
16. Power on the EXP100s.
17. After the green drive Activity LEDs on the drives in the EXP100 enclosures stop flashing and the EXP100 ESM Fault LED changes from amber to unlit, power on the FAStT storage server.

Wait at least four minutes after all of the drives in the EXP100 enclosures have spun up. The drives will show solidly lit or rapidly flashing green drive Activity LEDs.

18. Add Controller B to the Enterprise Management window of the FAStT Storage Manager client program.
  - a. In the Enterprise Management Window, click **Edit → Add Device**. Enter the TCP/IP address of Controller B and then click **Add** when the Add Device window opens.
  - b. If the Connection Problem window displays, click **No** to close the window and return to the Add Device window. Wait a few minutes and click **Add** to try to add Controller B to the Enterprise Management window again. If the problem persists, power off the storage server and repeat steps 16 through 18. Otherwise, continue with the next step.
19. Click **Close** to close the Add Device window. A window opens, warning that you have not added the second controller of the FAStT storage server controller pairs. Click **Close** to close this window.
20. In the Enterprise Management window, right-click the entry for Controller B (which you just added) and select **Manage Device** from the pop-up menu. A Partially Managed Notice window displays to warn that the storage subsystem that you are trying to manage has a controller that has not yet been added to the Enterprise Management window yet. Click **Yes** to launch the Subsystem Management window for this FAStT controller anyway.
21. A Subsystem Management window opens. Verify that all of the EXP100 drive expansion enclosures and drives are shown in the Subsystem Management window with Status displayed as `Optimal`.
22. Close the Controller B Subsystem Management window.
23. Insert Controller A into the FAStT storage server chassis.

This controller will be started up and its firmware and NVSRAM will sync automatically with the controller firmware and NVSRAM in Controller B. This process might take several minutes, depending on the number of EXP100 enclosures and drives in the FAStT storage server configuration. Wait at least five minutes (or 10 minutes in a large configuration; for example, one with 112 or more drives). Then attempt to add Controller A to the Enterprise Management window using the TCP/IP address for Controller A.

- If Controller A starts up successfully after syncing with the firmware and NVSRAM in Controller B, then Controller A will be added to the Enterprise Management window as part of the Controller B entry. When you right-click this entry and select **Manage Device**, a Subsystem Management window should open without being preceded by the Partially Manage Device window.
  - If the Subsystem Management window opens without reporting a problem, you can proceed with the other Storage Server management tasks, such as creating arrays, mappings logical drives to host partitions, and so on.
  - If the Connection Problem window opens, click **No** to close the window and return to the Add Device window. Wait a few more minutes and click **Add** to try to add Controller A to the Enterprise Management window again.  
If the problem persists after a few attempts, call your IBM technical support representative.
- If Controller A is added as a separate entry in the Enterprise Management window, close the Add Device window and delete the Controller A entry from the Enterprise Management window; then wait a few minutes and try to add Controller A again. (The problem could have been caused by Controller A not having had enough time to complete the sync-up with Controller B.)

If Controller A is added as a separate entry in the Enterprise Management window again, close the Add Device window and delete the Controller A entry from the Enterprise Management window; then, remove Controller A from the storage server chassis, wait a minute or so, and repeat step 23. If the problem persists, call your IBM technical support representative.





## Appendix B. ESM failover architecture

This appendix provides information about the ESM failover architecture for the FAStT EXP100. This appendix also details the guidelines for array configurations that offer maximum protection of data access in the event of ESM failure.

### Understanding ESM failover architecture

The FAStT EXP100 drive expansion enclosure architecture provides full failover support for a loss of connectivity due to bad components in the drive paths (such as bad SFPs, bad FC cables, and so on). However, each ESM in the FAStT EXP100 chassis manages only one-half of the drives in the FAStT EXP100 chassis. The left ESM manages drives at odd-numbered slots (1, 3, 5, 7, 9, 11, 13); the right ESM manages drives at even-numbered slots (2, 4, 6, 8, 10, 12, 14). As a result of this management requirement, if an ESM does fail, then one-half of the drives that are managed by the FAStT EXP100 could become inaccessible to the controllers.

Figure 44 shows a high-level diagram of the EXP100 ESM failover architecture.

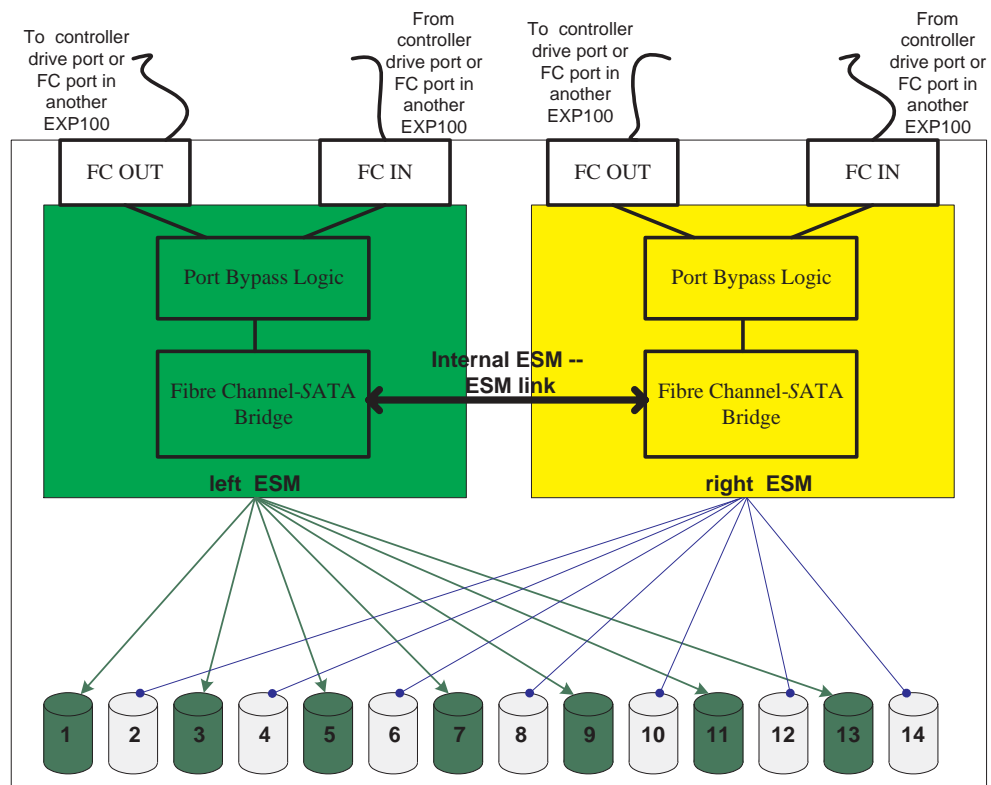

Figure 44. FAStT EXP100 ESM and drive paths

If there are failures in the fibre-channel data path to an ESM in the FAStT EXP100 enclosure, the FAStT controller reroutes its data to the ESM that it still can access by way of the fibre-channel path. Then, the ESM routes the data to the ESM that had fibre-channel connection problems using the internal ESM-ESM data path. This ESM in turn transfers the data to the disk drives that it had controlled.

Unless there are failures in the fibre-channel connections to both ESMs in the FAStT EXP100 chassis, the controller and ESM firmware work together to ensure that there is no loss of data availability. Figure 45 shows that if the fibre-channel connection to the left ESM is bad, then the data to drive 1, which is controlled by the left ESM, is routed through the right ESM fibre-channel input connection to the right ESM, through the internal ESM-ESM link to the left ESM, and then to drive 1.

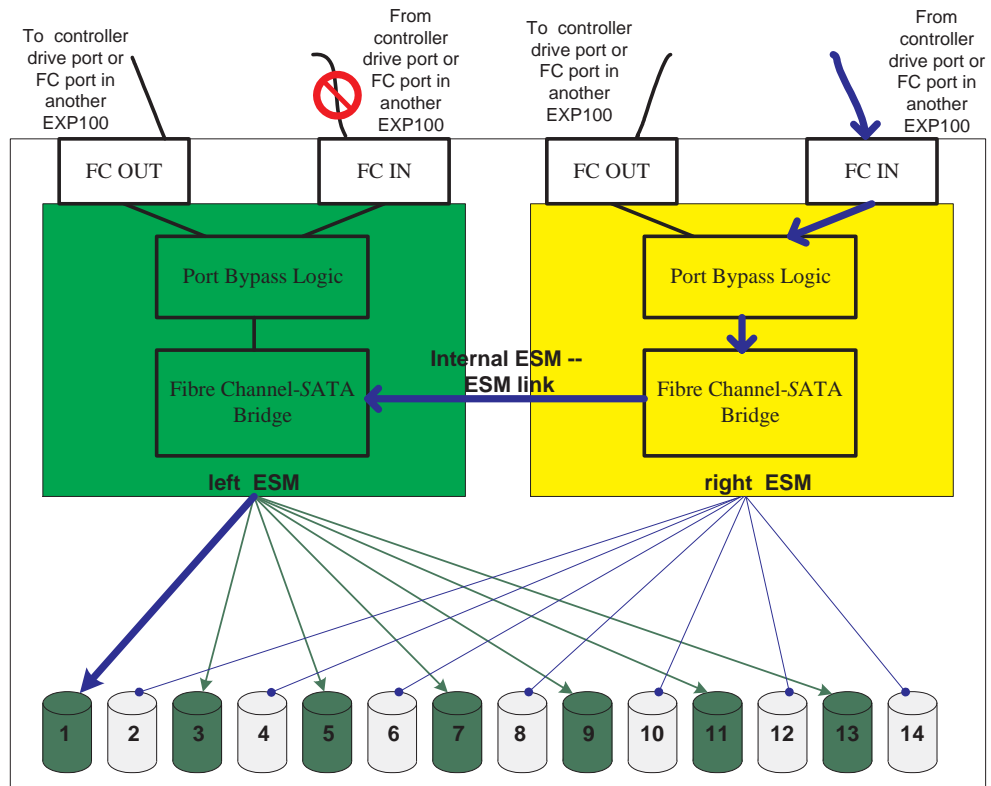

Figure 45. The right ESM and controller firmware recover from a loss of connectivity to the input port of the left ESM

However, if one of the ESMs fails, then data access to one-half of the drives in the EXP100 would be lost, as shown in Figure 46 on page 73.

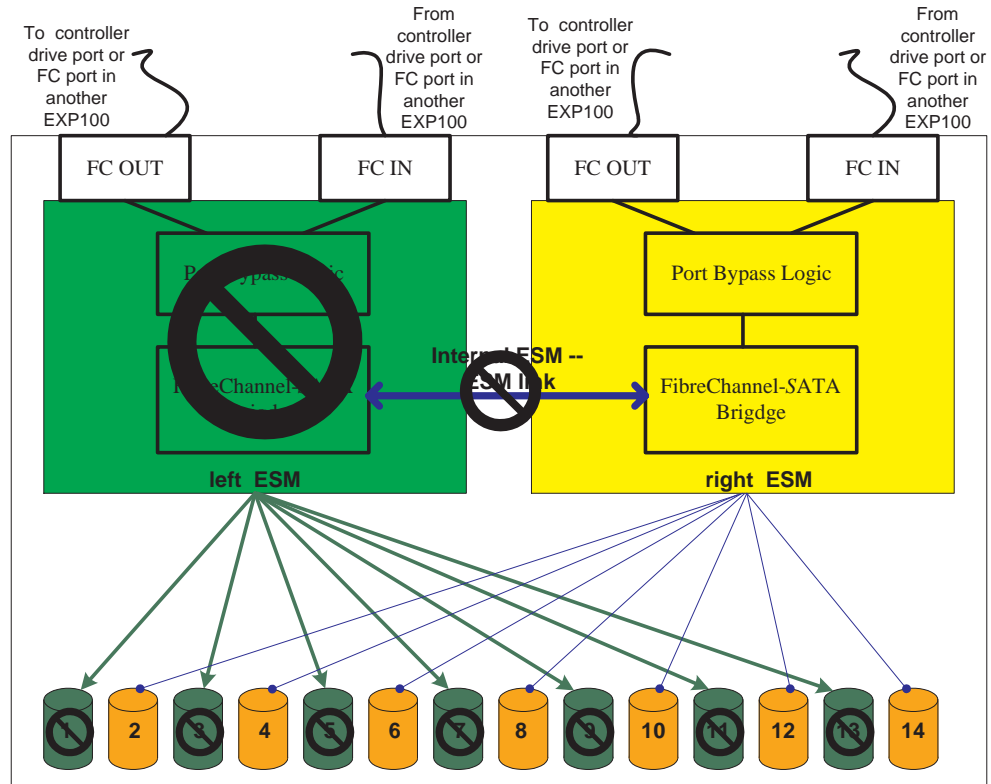

Figure 46. Loss of access to drives in odd-numbered drive slots because the left ESM itself failed

Based on IBM failure rate calculations, the failure shown in Figure 46 is extremely unlikely. ESM failure is no more likely in the FASTt EXP100 than in any other expansion unit. However, because an ESM failure in the FASTt EXP100 will result in a loss of data access, IBM provides the array configuration guidelines presented in the following section to ensure that you will not experience any loss of data availability when an ESM fails.

## ESM failover configuration guidelines

The initial release of the FASTt EXP100 is susceptible to a loss of data access in the event of an ESM failure. To reduce the possible impact of an ESM failure, you should use array configurations in which arrays are striped across multiple enclosures. If you do not follow the configuration guidelines detailed in this section, any ESM failure is more likely to result in the loss of data access.

**Attention:** The following guidelines require manual drive selection. When you create an array, do *not* select the Automatically Configure option; this option is based on a given number of drives that are used to make up an array. The Automatic Configuration tool does not recognize the fact that each ESM has control of only half of the drives in the FASTt EXP100 chassis. Instead, you must manually select the drives that are going to make up an array using one of the following two approaches:

- The best way to protect against the loss of data availability due to ESM or FASTt EXP100 failure is to orthogonally stripe the array over multiple enclosures. The disadvantage of this method lies in the number of FASTt EXP100 enclosures that you need for this type of striping.

To orthogonally stripe the array over multiple enclosures, you must have one FAStT EXP100 enclosure available for every drive that is to be defined in a RAID array. This means you would need two FAStT EXP100 enclosures to create a two-drive RAID-1. For a five-drive RAID-5 array, you would need five FAStT EXP100 enclosures (and so on, up to the maximum number of FAStT EXP100s that are supported with a particular storage server – 8 enclosures for the FAStT600 and 16 enclosures for the FAStT900).

Figure 47 and Figure 48 on page 75 show examples of arrays that are orthogonally striped over multiple FAStT EXP100 enclosures. If an ESM in a FAStT EXP100 failed, or even if the entire FAStT EXP100 enclosure failed, the defined arrays would enter a Degraded (but not Failed) state. Consequently, no direct data availability impact would occur in this situation, and ESM replacement could be used to restore the system to a fully optimal state without any loss of access to data.

For example, in Figure 47, an 8-drive RAID-1 array would be comprised of A1, B1, C1, and so on, through H1. In Figure 48 on page 75, an 8-drive RAID-1 array would be comprised of A1, B2, C1, and so on, through H2. Similarly, in Figure 47, an 8-drive RAID-5 array would be comprised of A1, B1, C1, and so on, through H1. In Figure 48 on page 75, an 8-drive RAID-5 array would be comprised of A1, B2, C1, and so on, through H2.

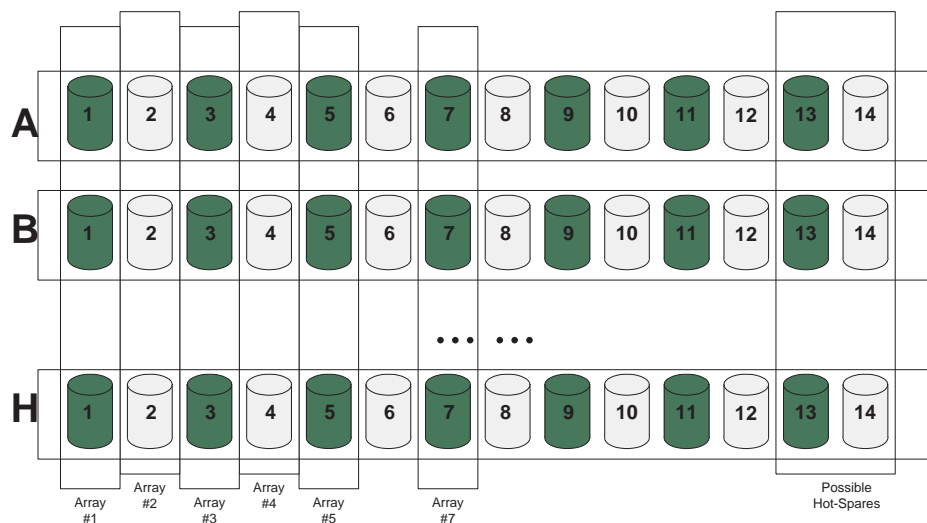

Figure 47. Orthogonally striped RAID arrays – Option 1

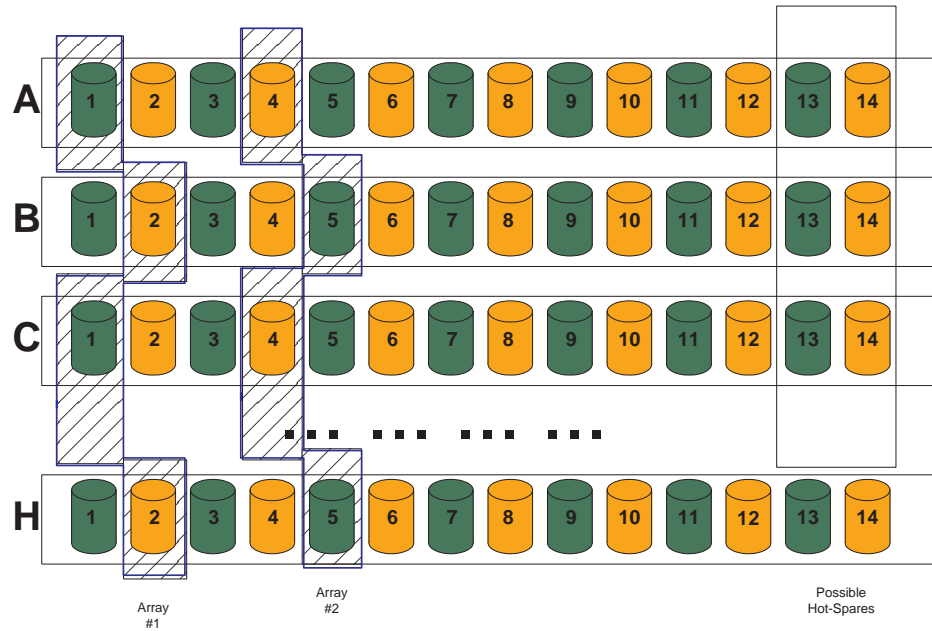

Figure 48. Orthogonally striped RAID arrays – Option 2

- An alternative approach, shown in Figure 49 on page 76, provides protection against single ESM failure, but not against a failure of the entire FASTT EXP100. This approach allows up to two drives in a given FASTT EXP100 enclosure to be part of an RAID array. One of the drives must be in any of the odd-numbered drive slots. The other drive must be in an even-numbered drive slot. If the array requires more than two drives, it must be defined over multiple FASTT EXP100 enclosures.

The advantage of this approach is that the number of required FASTT EXP100 enclosures can be reduced by 50% in comparison to the number of enclosures that are required in the first approach. If an ESM in a FASTT EXP100 failed, the defined arrays would enter a Degraded (but not Failed) state. Consequently, no direct data availability impact would occur in this situation, and ESM replacement could be used to restore the system to a fully optimal state without any loss of access to data.

**Note:** In this configuration, the array might be exposed to the loss of data availability if there is a drive failure in the array in a given FASTT EXP100 *and* if the hot-spare drive is controlled by the same ESM as the surviving drive.

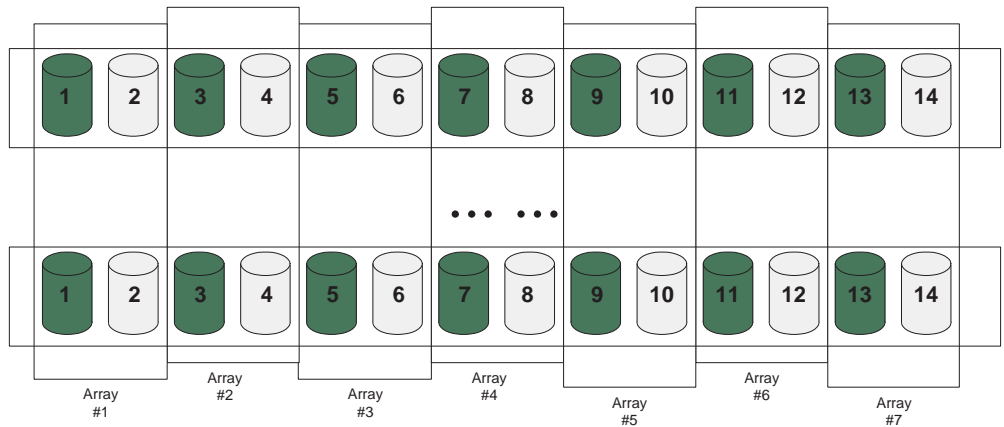

Figure 49. Using up two drives in a FAStT EXP100 in the RAID array

In summary, if these guidelines are followed, then the loss of an ESM (or a related fault) will cause logical drives to be marked Degraded, but not Failed. Consequently, no direct data availability impact will occur, and ESM replacement can be used to restore the system to a fully optimal state without any loss of access to data.

**Additional considerations:**

1. Do not remove an ESM from the FAStT EXP100 chassis unless it is required as part of ESM replacement.
2. Do not download ESM firmware while drives are active. There should be no drive activity (I/O) from the host while the ESM firmware and drive firmware upgrades.
3. Clustering services like Microsoft MSCS must be stopped if the cluster disks and quorum disks are defined by using the disks in the EXP100 enclosures whose ESMs are being updated with new firmware.







---

## Appendix D. Rack mounting template

This appendix provides duplicate copies of the rack mounting templates. If you want to tear out the templates from this document for easier use, use these copies rather than those provided in “Rack mounting template” on page 18.

Use the following templates (Figure 50 on page 80 and Figure 51 on page 81) to identify the proper locations for inserting M6 screws when mounting the support rails and FAST EXP100 to a rack. The locations for the M6 screws are highlighted in the templates.

The FAStT EXP100 is 3 U high. Align the template with the rack at a U boundary. U boundaries are shown as horizontal dashed lines in the rack mounting templates.

**Note:** The mounting holes that are shown in the following templates are square. The holes in your rack might be round or square.

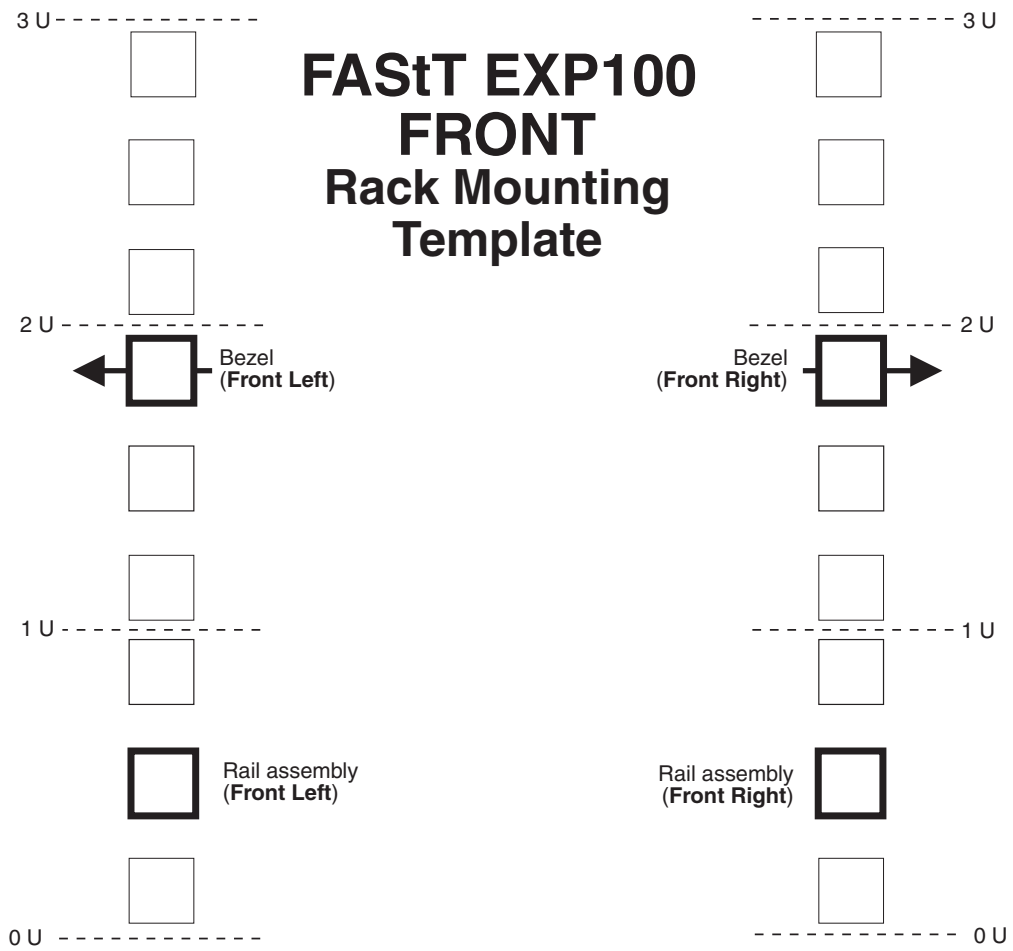

Figure 50. Front rack mounting template

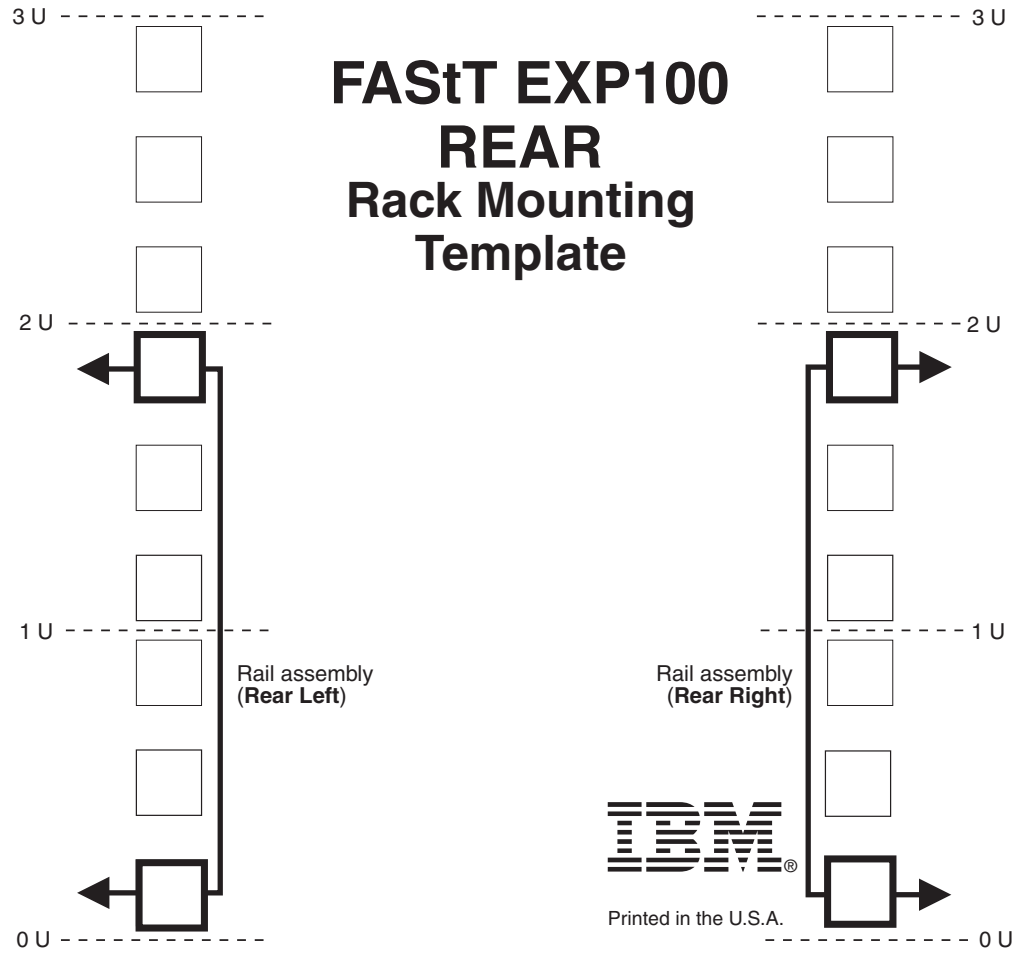

Figure 51. Rear rack mounting template



---

## Appendix E. Power cords

For your safety, IBM® provides a power cord with a grounded attachment plug to use with this IBM product. To avoid electrical shock, always use the power cord and plug with a properly grounded outlet.

IBM power cords used in the United States and Canada are listed by Underwriter's Laboratories (UL) and certified by the Canadian Standards Association (CSA).

For units intended to be operated at 115 volts: Use a UL-listed and CSA-certified cord set consisting of a minimum 18 AWG, Type SVT or SJT, three-conductor cord, a maximum of 15 feet in length and a parallel blade, grounding-type attachment plug rated 15 amperes, 125 volts.

For units intended to be operated at 230 volts (U.S. use): Use a UL-listed and CSA-certified cord set consisting of a minimum 18 AWG, Type SVT or SJT, three-conductor cord, a maximum of 15 feet in length and a tandem blade, grounding-type attachment plug rated 15 amperes, 250 volts.

For units intended to be operated at 230 volts (outside the U.S.): Use a cord set with a grounding-type attachment plug. The cord set should have the appropriate safety approvals for the country in which the equipment will be installed.

IBM power cords for a specific country or region are usually available only in that country or region.

---

<b>IBM power cord part number</b>	<b>Used in these countries or regions</b>
13F9940	Argentina, Australia, China (PRC), New Zealand, Papua New Guinea, Paraguay, Uruguay, Western Samoa
13F9979	Afghanistan, Algeria, Andorra, Angola, Austria, Belgium, Benin, Bulgaria, Burkina Faso, Burundi, Cameroon, Central African Rep., Chad, Czech Republic, Egypt, Finland, France, French Guiana, Germany, Greece, Guinea, Hungary, Iceland, Indonesia, Iran, Ivory Coast, Jordan, Lebanon, Luxembourg, Macau S.A.R. of China, Malagasy, Mali, Martinique, Mauritania, Mauritius, Monaco, Morocco, Mozambique, Netherlands, New Caledonia, Niger, Norway, Poland, Portugal, Romania, Senegal, Slovakia, Spain, Sudan, Sweden, Syria, Togo, Tunisia, Turkey, former USSR, Vietnam, former Yugoslavia, Zaire, Zimbabwe
13F9997	Denmark
14F0015	Bangladesh, Burma, Pakistan, South Africa, Sri Lanka
14F0033	Antigua, Bahrain, Brunei, Channel Islands, Cyprus, Dubai, Fiji, Ghana, Hong Kong S.A.R. of China, India, Iraq, Ireland, Kenya, Kuwait, Malawi, Malaysia, Malta, Nepal, Nigeria, Polynesia, Qatar, Sierra Leone, Singapore, Tanzania, Uganda, United Kingdom, Yemen, Zambia
14F0051	Liechtenstein, Switzerland
14F0069	Chile, Ethiopia, Italy, Libya, Somalia
14F0087	Israel
1838574	Thailand

---

---

<b>IBM power cord part number</b>	<b>Used in these countries or regions</b>
6952301	Bahamas, Barbados, Bermuda, Bolivia, Brazil, Canada, Cayman Islands, Colombia, Costa Rica, Dominican Republic, Ecuador, El Salvador, Guatemala, Guyana, Haiti, Honduras, Jamaica, Japan, Korea (South), Liberia, Mexico, Netherlands Antilles, Nicaragua, Panama, Peru, Philippines, Saudi Arabia, Suriname, Taiwan, Trinidad (West Indies), United States of America, Venezuela

---

---

## Notices

This publication was developed for products and services offered in the U.S.A.

IBM may not offer the products, services, or features discussed in this document in other countries. Consult your local IBM representative for information on the products and services currently available in your area. Any reference to an IBM product, program, or service is not intended to state or imply that only that IBM product, program, or service may be used. Any functionally equivalent product, program, or service that does not infringe any IBM intellectual property right may be used instead. However, it is the user's responsibility to evaluate and verify the operation of any non-IBM product, program, or service.

IBM may have patents or pending patent applications covering subject matter described in this document. The furnishing of this document does not give you any license to these patents. You can send license inquiries, in writing, to:

*IBM Director of Licensing  
IBM Corporation  
North Castle Drive  
Armonk, NY 10504-1785  
U.S.A.*

INTERNATIONAL BUSINESS MACHINES CORPORATION PROVIDES THIS PUBLICATION "AS IS" WITHOUT WARRANTY OF ANY KIND, EITHER EXPRESS OR IMPLIED, INCLUDING, BUT NOT LIMITED TO, THE IMPLIED WARRANTIES OF NON-INFRINGEMENT, MERCHANTABILITY OR FITNESS FOR A PARTICULAR PURPOSE. Some jurisdictions do not allow disclaimer of express or implied warranties in certain transactions, therefore, this statement may not apply to you.

This information could include technical inaccuracies or typographical errors. Changes are periodically made to the information herein; these changes will be incorporated in new editions of the publication. IBM may make improvements and/or changes in the product(s) and/or the program(s) described in this publication at any time without notice.

Any references in this publication to non-IBM Web sites are provided for convenience only and do not in any manner serve as an endorsement of those Web sites. The materials at those Web sites are not part of the materials for this IBM product, and use of those Web sites is at your own risk.

IBM may use or distribute any of the information you supply in any way it believes appropriate without incurring any obligation to you.

---

## Trademarks

The following terms are trademarks of International Business Machines Corporation in the United States, other countries, or both:

IBM	ServerProven
eServer logo	TotalStorage
IntelliStation	xSeries
Netfinity	

Intel is a trademark of Intel Corporation in the United States, other countries, or both.

Java and all Java-based trademarks and logos are trademarks or registered trademarks of Sun Microsystems, Inc. in the United States, other countries, or both.

Other company, product, or service names may be trademarks or service marks of others.

---

## Important notes

Processor speeds indicate the internal clock speed of the microprocessor; other factors also affect application performance.

CD-ROM drive speeds list the variable read rate. Actual speeds vary and are often less than the maximum possible.

When referring to processor storage, real and virtual storage, or channel volume, KB stands for approximately 1000 bytes, MB stands for approximately 1 000 000 bytes, and GB stands for approximately 1 000 000 000 bytes.

When referring to hard disk drive capacity or communications volume, MB stands for 1 000 000 bytes, and GB stands for 1 000 000 000 bytes. Total user-accessible capacity may vary depending on operating environments.

Maximum internal hard disk drive capacities assume the replacement of any standard hard disk drives and population of all hard disk drive bays with the largest currently supported drives available from IBM.

Maximum memory may require replacement of the standard memory with an optional memory module.

IBM makes no representation or warranties regarding non-IBM products and services that are ServerProven<sup>®</sup>, including but not limited to the implied warranties of merchantability and fitness for a particular purpose. These products are offered and warranted solely by third parties.

IBM makes no representations or warranties with respect to non-IBM products. Support (if any) for the non-IBM products is provided by the third party, not IBM.

Some software may differ from its retail version (if available), and may not include user manuals or all program functionality.

---

## Electronic emission notices

This section gives the electronic emission notices or statements for the United States and other countries or regions.

## Federal Communications Commission (FCC) statement

**Note:** This equipment has been tested and found to comply with the limits for a Class A digital device, pursuant to Part 15 of the FCC Rules. These limits are designed to provide reasonable protection against harmful interference when the equipment is operated in a commercial environment. This equipment generates, uses, and can radiate radio frequency energy and, if not installed and used in accordance with the instruction manual, may cause harmful interference to radio



communications. Operation of this equipment in a residential area is likely to cause harmful interference, in which case the user will be required to correct the interference at his own expense.

Properly shielded and grounded cables and connectors must be used in order to meet FCC emission limits. IBM is not responsible for any radio or television interference caused by using other than recommended cables and connectors or by using other than recommended cables and connectors or by unauthorized changes or modifications to this equipment. Unauthorized changes or modifications could void the user's authority to operate the equipment.

This device complies with Part 15 of the FCC Rules. Operation is subject to the following two conditions: (1) this device may not cause harmful interference, and (2) this device must accept any interference received, including interference that may cause undesired operation.

## Chinese class A compliance statement

**Attention:** This is a class A statement. In a domestic environment, this product might cause radio interference in which case the user might be required to take adequate measures.

中华人民共和国“A类”警告声明

声明

此为A级产品，在生活环境中，该产品可能会造成无线电干扰。在这种情况下，可能需要用户对其干扰采取切实可行的措施。

## Industry Canada Class A emission compliance statement

This Class A digital apparatus complies with Canadian ICES-003.

**Avis de conformité à la réglementation d'Industrie Canada**

Cet appareil numérique de la classe A est conforme à la norme NMB-003 du Canada.

## Australia and New Zealand Class A statement

**Attention:** This is a Class A product. In a domestic environment this product may cause radio interference in which case the user may be required to take adequate measures.

## United Kingdom telecommunications safety requirement

**Notice to Customers**

This apparatus is approved under approval number NS/G/1234/J/100003 for indirect connection to public telecommunication systems in the United Kingdom.

## European Union EMC Directive conformance statement

This product is in conformity with the protection requirements of EU Council Directive 89/336/EEC on the approximation of the laws of the Member States relating to electromagnetic compatibility. IBM cannot accept responsibility for any failure to satisfy the protection requirements resulting from a nonrecommended modification of the product, including the fitting of non-IBM option cards.

This product has been tested and found to comply with the limits for Class A Information Technology Equipment according to CISPR 22/European Standard EN 55022. The limits for Class A equipment were derived for commercial and industrial environments to provide reasonable protection against interference with licensed communication equipment.

**Attention:** This is a Class A product. In a domestic environment this product may cause radio interference in which case the user may be required to take adequate measures.

## Taiwan Class A warning statement

警告使用者：  
這是甲類的資訊產品，在居住的環境中使用時，可能會造成射頻干擾，在這種情況下，使用者會被要求採取某些適當的對策。

## Japanese Voluntary Control Council for Interference (VCCI) statement

この装置は、情報処理装置等電波障害自主規制協議会（VCCI）の基準に基づくクラスA情報技術装置です。この装置を家庭環境で使用すると電波妨害を引き起こすことがあります。この場合には使用者が適切な対策を講ずるよう要求されることがあります。

---

## Glossary

This glossary provides definitions for the terminology used for the IBM TotalStorage FAStT. This glossary also provides definitions for the terminology used for the IBM TotalStorage FAStT Storage Manager.

This glossary defines technical terms and abbreviations used in this document. If you do not find the term you are looking for, see the *IBM Glossary of Computing Terms* located at: [www.ibm.com/networking/nsg/nsgmain.htm](http://www.ibm.com/networking/nsg/nsgmain.htm)

This glossary also includes terms and definitions from:

- *Information Technology Vocabulary* by Subcommittee 1, Joint Technical Committee 1, of the International Organization for Standardization and the International Electrotechnical Commission (ISO/IEC JTC1/SC1). Definitions are identified by the symbol (I) after the definition; definitions taken from draft international standards, committee drafts, and working papers by ISO/IEC JTC1/SC1 are identified by the symbol (T) after the definition, indicating that final agreement has not yet been reached among the participating National Bodies of SC1.
- *IBM Glossary of Computing Terms*. New York: McGraw-Hill, 1994.

The following cross-reference conventions are used in this glossary:

**See** Refers you to (a) a term that is the expanded form of an abbreviation or acronym, or (b) a synonym or more preferred term.

### See also

Refers you to a related term.

**Abstract Windowing Toolkit (AWT).** A Java graphical user interface (GUI).

**accelerated graphics port (AGP).** A bus specification that gives low-cost 3D graphics cards faster access to main memory on personal computers than the usual peripheral component interconnect (PCI) bus. AGP reduces the overall cost of creating high-end graphics subsystems by using existing system memory.

**access volume.** A special logical drive that allows the host-agent to communicate with the controllers in the storage subsystem.

**adapter.** A printed circuit assembly that transmits user data input/output (I/O) between the internal bus of the host system and the external fibre-channel (FC) link and vice versa. Also called an I/O adapter, host adapter, or FC adapter.

**advanced technology (AT) bus architecture.** A bus standard for IBM compatibles. It extends the XT bus architecture to 16 bits and also allows for bus mastering, although only the first 16 MB of main memory are available for direct access.

**agent.** A server program that receives virtual connections from the network manager (the client program) in a Simple Network Management Protocol-Transmission Control Protocol/Internet Protocol (SNMP-TCP/IP) network-managing environment.

**AGP.** See *accelerated graphics port*.

**AL\_PA.** See *arbitrated loop physical address*.

**arbitrated loop.** One of three existing fibre-channel topologies, in which 2 - 126 ports are interconnected serially in a single loop circuit. Access to the Fibre Channel-Arbitrated Loop (FC-AL) is controlled by an arbitration scheme. The FC-AL topology supports all classes of service and guarantees in-order delivery of FC frames when the originator and responder are on the same FC-AL. The default topology for the disk array is arbitrated loop. An arbitrated loop is sometimes referred to as a Stealth Mode.

**arbitrated loop physical address (AL\_PA).** An 8-bit value that is used to uniquely identify an individual port within a loop. A loop can have one or more AL\_PAs.

**AT.** See *advanced technology (AT) bus architecture*.

**ATA.** See *AT-attached*.

**AT-attached.** Peripheral devices that are compatible with the original IBM AT computer standard in which signals on a 40-pin AT-attached (ATA) ribbon cable followed the timings and constraints of the Industry Standard Architecture (ISA) system bus on the IBM PC AT computer. Equivalent to integrated drive electronics (IDE).

**auto-volume transfer/auto-disk transfer (AVT/ADT).** A function that provides automatic failover in case of controller failure on a storage subsystem.

**AVT/ADT.** See *auto-volume transfer/auto-disk transfer*.

**AWT.** See *Abstract Windowing Toolkit*.

**basic input/output system (BIOS).** The personal computer code that controls basic hardware operations, such as interactions with diskette drives, hard disk drives, and the keyboard.

**BIOS.** See *basic input/output system*.

**BOOTP.** See *bootstrap protocol*.

**bootstrap protocol (BOOTP).** In Transmission Control Protocol/Internet Protocol (TCP/IP) networking, an alternative protocol by which a diskless machine can obtain its Internet Protocol (IP) address and such configuration information as IP addresses of various servers from a BOOTP server.

**bridge.** A storage area network (SAN) device that provides physical and transport conversion, such as fibre channel to small computer system interface (SCSI) bridge.

**bridge group.** A bridge and the collection of devices connected to it.

**broadcast.** The simultaneous transmission of data to more than one destination.

**cathode ray tube (CRT).** A display device in which controlled electron beams are used to display alphanumeric or graphical data on an electroluminescent screen.

**client.** A computer system or process that requests a service of another computer system or process that is typically referred to as a server. Multiple clients can share access to a common server.

**command.** A statement used to initiate an action or start a service. A command consists of the command name abbreviation, and its parameters and flags if applicable. A command can be issued by typing it on a command line or selecting it from a menu.

**community string.** The name of a community contained in each Simple Network Management Protocol (SNMP) message.

**CRC.** See *cyclic redundancy check*.

**CRT.** See *cathode ray tube*.

**CRU.** See *customer replaceable unit*.

**customer replaceable unit (CRU).** An assembly or part that a customer can replace in its entirety when any of its components fail. Contrast with *field replaceable unit (FRU)*.

**cyclic redundancy check (CRC).** (1) A redundancy check in which the check key is generated by a cyclic algorithm. (2) An error detection technique performed at both the sending and receiving stations.

**dac.** See *disk array controller*.

**dar.** See *disk array router*.

**DASD.** See *direct access storage device*.

**default host group.** A logical collection of discovered host ports, defined host computers, and defined host groups in the storage-partition topology that fulfill the following requirements:

- Are not involved in specific logical drive-to-LUN mappings
- Share access to logical drives with default logical drive-to-LUN mappings

**device type.** Identifier used to place devices in the physical map, such as the switch, hub, or storage.

**DHCP.** See *Dynamic Host Configuration Protocol*.

**direct access storage device (DASD).** A device in which access time is effectively independent of the location of the data. Information is entered and retrieved without reference to previously accessed data. (For example, a disk drive is a DASD, in contrast with a tape drive, which stores data as a linear sequence.) DASDs include both fixed and removable storage devices.

**direct memory access (DMA).** The transfer of data between memory and an input/output (I/O) device without processor intervention.

**disk array controller (dac).** A disk array controller device that represents the two controllers of an array. See also *disk array router*.

**disk array router (dar).** A disk array router that represents an entire array, including current and deferred paths to all logical unit numbers (LUNs) (hdisks on AIX). See also *disk array controller*.

**DMA.** See *direct memory access*.

**domain.** The most significant byte in the node port (N\_port) identifier for the fibre-channel (FC) device. It is not used in the fibre channel-small computer system interface (FC-SCSI) hardware path ID. It is required to be the same for all SCSI targets logically connected to an FC adapter.

**DRAM.** See *dynamic random access memory*.

**Dynamic Host Configuration Protocol (DHCP).** A protocol defined by the Internet Engineering Task Force that is used for dynamically assigning Internet Protocol (IP) addresses to computers in a network.

**dynamic random access memory (DRAM).** A storage in which the cells require repetitive application of control signals to retain stored data.

**ECC.** See *error correction coding*.

**EEPROM.** See *electrically erasable programmable read-only memory*.

**EISA.** See *Extended Industry Standard Architecture*.

**electrically erasable programmable read-only memory (EEPROM).** A type of memory chip which can retain its contents without consistent electrical power. Unlike the PROM which can be programmed only once, the EEPROM can be erased electrically. Because it can only be reprogrammed a limited number of times before it wears out, it is appropriate for storing small amounts of data that are changed infrequently.

**electrostatic discharge (ESD).** The flow of current that results when objects that have a static charge come into close enough proximity to discharge.

**environmental services monitor (ESM) canister.** A component in a drive enclosure that monitors the environmental condition of the components in that enclosure. Not all storage subsystems have ESM canisters.

**E\_port.** See *expansion port*.

**error correction coding (ECC).** A method for encoding data so that transmission errors can be detected and corrected by examining the data on the receiving end. Most ECCs are characterized by the maximum number of errors they can detect and correct.

**ESD.** See *electrostatic discharge*.

**ESM canister.** See *environmental services monitor canister*.

**EXP.** See *expansion unit*.

**expansion port (E\_port).** A port that connects the switches for two fabrics.

**expansion unit (EXP).** A feature that can be connected to a system unit to provide additional storage and processing capacity.

**Extended Industry Standard Architecture (EISA).** A bus standard for IBM compatibles that extends the Industry Standard Architecture (ISA) bus architecture to 32 bits and allows more than one central processing unit (CPU) to share the bus. See also *Industry Standard Architecture*.

**fabric.** A Fibre Channel entity which interconnects and facilitates logins of N\_ports attached to it. The fabric is responsible for routing frames between source and destination N\_ports using address information in the frame header. A fabric can be as simple as a point-to-point channel between two N-ports, or as complex as a frame-routing switch that provides multiple and redundant internal pathways within the fabric between F\_ports.

**fabric port (F\_port).** In a fabric, an access point for connecting a user's N\_port. An F\_port facilitates N\_port

logins to the fabric from nodes connected to the fabric. An F\_port is addressable by the N\_port connected to it. See also *fabric*.

**FAStT MSJ.** See *FAStT Management Suite Java*.

**FAStT Management Suite Java (FAStT MSJ).** A diagnostic and configuration utility that can be used on Linux, Microsoft Windows, and Novell NetWare host systems. In Linux, it is also used with the QLRemote agent to define preferred and non-preferred paths for logical drives.

**FC.** See *fibre channel*.

**FC-AL.** See *arbitrated loop*.

**feature enable identifier.** A unique identifier for the storage subsystem, which is used in the process of generating a premium feature key. See also *premium feature key*.

**fibre channel (FC).** A set of standards for a serial input/output (I/O) bus capable of transferring data between two ports at up to 100 Mbps, with standards proposals to go to higher speeds. FC supports point-to-point, arbitrated loop, and switched topologies.

**Fibre Channel-Arbitrated Loop (FC-AL).** See *arbitrated loop*.

**Fibre Channel Protocol (FCP) for small computer system interface (SCSI).** A high-level fibre-channel mapping layer (FC-4) that uses lower-level fibre-channel (FC-PH) services to transmit SCSI commands, data, and status information between a SCSI initiator and a SCSI target across the FC link by using FC frame and sequence formats.

**field replaceable unit (FRU).** An assembly that is replaced in its entirety when any one of its components fails. In some cases, a field replaceable unit might contain other field replaceable units. Contrast with *customer replaceable unit (CRU)*.

**FlashCopy.** A premium feature for FAStT that can make an instantaneous copy of the data in a volume.

**F\_port.** See *fabric port*.

**FRU.** See *field replaceable unit*.

**GBIC.** See *gigabit interface converter*

**gigabit interface converter (GBIC).** A transceiver that performs serial, optical-to-electrical, and electrical-to-optical signal conversions for high-speed networking. A GBIC can be hot swapped. See also *small form-factor pluggable*.

**graphical user interface (GUI).** A type of computer interface that presents a visual metaphor of a real-world scene, often of a desktop, by combining high-resolution



graphics, pointing devices, menu bars and other menus, overlapping windows, icons, and the object-action relationship.

**GUI.** See *graphical user interface*.

**HBA.** See *host bus adapter*.

**hdisk.** An AIX term representing a logical unit number (LUN) on an array.

**host.** A system that is directly attached to the storage subsystem through a fibre-channel input/output (I/O) path. This system is used to serve data (typically in the form of files) from the storage subsystem. A system can be both a storage management station and a host simultaneously.

**host bus adapter (HBA).** An interface between the fibre-channel network and a workstation or server.

**host computer.** See *host*.

**host group.** An entity in the storage partition topology that defines a logical collection of host computers that require shared access to one or more logical drives.

**host port.** Ports that physically reside on the host adapters and are automatically discovered by the FAS*St* Storage Manager software. To give a host computer access to a partition, its associated host ports must be defined.

**hot swap.** To replace a hardware component without turning off the system.

**hub.** In a network, a point at which circuits are either connected or switched. For example, in a star network, the hub is the central node; in a star/ring network, it is the location of wiring concentrators.

**IBMSAN driver.** The device driver that is used in a Novell NetWare environment to provide multipath input/output (I/O) support to the storage controller.

**IC.** See *integrated circuit*.

**IDE.** See *integrated drive electronics*.

**in-band.** Transmission of management protocol over the fibre-channel transport.

**Industry Standard Architecture (ISA).** Unofficial name for the bus architecture of the IBM PC/XT personal computer. This bus design included expansion slots for plugging in various adapter boards. Early versions had an 8-bit data path, later expanded to 16 bits. The "Extended Industry Standard Architecture" (EISA) further expanded the data path to 32 bits. See also *Extended Industry Standard Architecture*.

**initial program load (IPL).** The initialization procedure that causes an operating system to commence operation. Also referred to as a system restart, system startup, and boot.

**integrated circuit (IC).** A microelectronic semiconductor device that consists of many interconnected transistors and other components. ICs are constructed on a small rectangle cut from a silicon crystal or other semiconductor material. The small size of these circuits allows high speed, low power dissipation, and reduced manufacturing cost compared with board-level integration. Also known as a *chip*.

**integrated drive electronics (IDE).** A disk drive interface based on the 16-bit IBM personal computer Industry Standard Architecture (ISA) in which the controller electronics reside on the drive itself, eliminating the need for a separate adapter card. Also known as an Advanced Technology Attachment Interface (ATA).

**Internet Protocol (IP).** A protocol that routes data through a network or interconnected networks. IP acts as an intermediary between the higher protocol layers and the physical network.

**Internet Protocol (IP) address.** The unique 32-bit address that specifies the location of each device or workstation on the Internet. For example, 9.67.97.103 is an IP address.

**interrupt request (IRQ).** A type of input found on many processors that causes the processor to suspend normal processing temporarily and start running an interrupt handler routine. Some processors have several interrupt request inputs that allow different priority interrupts.

**IP.** See *Internet Protocol*.

**IPL.** See *initial program load*.

**IRQ.** See *interrupt request*.

**ISA.** See *Industry Standard Architecture*.

**isolated group.** A collection of isolated devices not connected to the storage area network (SAN) but discovered by the SANavigator tool. The isolated group displays with a gray background near the bottom of the Physical and Data Path maps.

**Java Runtime Environment (JRE).** A subset of the Java Development Kit (JDK) for end users and developers who want to redistribute the Java Runtime Environment (JRE). The JRE consists of the Java virtual machine, the Java Core Classes, and supporting files.

**JRE.** See *Java Runtime Environment*.

**label.** A discovered or user entered property value that is displayed underneath each device in the Physical and Data Path maps.

**LAN.** See *local area network*.

**LBA.** See *logical block address*.

**local area network (LAN).** A computer network located on a user's premises within a limited geographic area.

**logical block address (LBA).** The address of a logical block. Logical block addresses are typically used in hosts' I/O commands. The SCSI disk command protocol, for example, uses logical block addresses.

**logical unit number (LUN).** An identifier used on a small computer system interface (SCSI) bus to distinguish among up to eight devices (logical units) with the same SCSI ID.

**loop address.** The unique ID of a node in fibre-channel loop topology sometimes referred to as a loop ID.

**loop group.** A collection of storage area network (SAN) devices that are interconnected serially in a single loop circuit. Loop groups are discovered by the SANavigator tool and displayed with a gray background on the Physical and Data Path maps.

**loop port.** A node port (N\_port) or fabric port (F\_port) that supports arbitrated loop functions associated with an arbitrated loop topology.

**LUN.** See *logical unit number*.

**MAC.** See *medium access control*.

**management information base (MIB).** The information that is on an agent. It is an abstraction of configuration and status information.

**man pages.** In UNIX-based operating systems, online documentation for operating system commands, subroutines, system calls, file formats, special files, stand-alone utilities, and miscellaneous facilities. Invoked by the **man** command.

**MCA.** See *micro channel architecture*.

**medium access control (MAC).** In local area networks (LANs), the sublayer of the data link control layer that supports medium-dependent functions and uses the services of the physical layer to provide services to the logical link control sublayer. The MAC sublayer includes the method of determining when a device has access to the transmission medium.

**MIB.** See *management information base*.

**micro channel architecture (MCA).** Hardware that is used for PS/2 Model 50 computers and above to

provide better growth potential and performance characteristics when compared with the original personal computer design.

**model.** The model identification that is assigned to a device by its manufacturer.

**network management station (NMS).** In the Simple Network Management Protocol (SNMP), a station that runs management application programs that monitor and control network elements.

**NMI.** See *non-maskable interrupt*.

**NMS.** See *network management station*.

**non-maskable interrupt (NMI).** A hardware interrupt that another service request cannot overrule (mask). An NMI bypasses and takes priority over interrupt requests generated by software, the keyboard, and other such devices and is issued to the microprocessor only in disastrous circumstances, such as severe memory errors or impending power failures.

**node.** A physical device that allows for the transmission of data within a network.

**node port (N\_port).** A fibre-channel defined hardware entity that performs data communications over the fibre-channel link. It is identifiable by a unique worldwide name. It can act as an originator or a responder.

**nonvolatile storage (NVS).** A storage device whose contents are not lost when power is cut off.

**N\_port.** See *node port*.

**NVS.** See *nonvolatile storage*.

**NVSRAM.** Nonvolatile storage random access memory. See *nonvolatile storage*.

**Object Data Manager (ODM).** An AIX proprietary storage mechanism for ASCII stanza files that are edited as part of configuring a drive into the kernel.

**ODM.** See *Object Data Manager*.

**out-of-band.** Transmission of management protocols outside of the fibre-channel network, typically over Ethernet.

**PCI local bus.** See *peripheral component interconnect local bus*.

**PDF.** See *portable document format*.

**performance events.** Events related to thresholds set on storage area network (SAN) performance.

**peripheral component interconnect local bus (PCI local bus).** A local bus for PCs, from Intel, that provides a high-speed data path between the CPU and up to 10 peripherals (video, disk, network, and so on).

The PCI bus coexists in the PC with the Industry Standard Architecture (ISA) or Extended Industry Standard Architecture (EISA) bus. ISA and EISA boards plug into an IA or EISA slot, while high-speed PCI controllers plug into a PCI slot. See also *Industry Standard Architecture, Extended Industry Standard Architecture*.

**polling delay.** The time in seconds between successive discovery processes during which discovery is inactive.

**port.** A part of the system unit or remote controller to which cables for external devices (such as display stations, terminals, printers, switches, or external storage units) are attached. The port is an access point for data entry or exit. A device can contain one or more ports.

**portable document format (PDF).** A standard specified by Adobe Systems, Incorporated, for the electronic distribution of documents. PDF files are compact; can be distributed globally by e-mail, the Web, intranets, or CD-ROM; and can be viewed with the Acrobat Reader, which is software from Adobe Systems that can be downloaded at no cost from the Adobe Systems home page.

**premium feature key.** A file that the storage subsystem controller uses to enable an authorized premium feature. The file contains the feature enable identifier of the storage subsystem for which the premium feature is authorized, and data about the premium feature. See also *feature enable identifier*.

**private loop.** A freestanding arbitrated loop with no fabric attachment. See also *arbitrated loop*.

**program temporary fix (PTF).** A temporary solution or bypass of a problem diagnosed by IBM in a current unaltered release of the program.

**PTF.** See *program temporary fix*.

**RAID.** See *redundant array of independent disks*.

**RAM.** See *random-access memory*.

**random-access memory (RAM).** A temporary storage location in which the central processing unit (CPU) stores and executes its processes. Contrast with *DASD*.

**RDAC.** See *redundant disk array controller*.

**read-only memory (ROM).** Memory in which stored data cannot be changed by the user except under special conditions.

**recoverable virtual shared disk (RVSD).** A virtual shared disk on a server node configured to provide continuous access to data and file systems in a cluster.

**redundant array of independent disks (RAID).** A collection of disk drives that appears as a single volume to the server and are fault tolerant through mirroring or parity checking.

**redundant disk array controller (RDAC).** (1) In hardware, a redundant set of controllers (either active/passive or active/active). (2) In software, a layer that manages the input/output (I/O) through the active controller during normal operation and transparently reroutes I/Os to the other controller in the redundant set if a controller or I/O path fails.

**ROM.** See *read-only memory*.

**router.** A computer that determines the path of network traffic flow. The path selection is made from several paths based on information obtained from specific protocols, algorithms that attempt to identify the shortest or best path, and other criteria such as metrics or protocol-specific destination addresses.

**RVSD.** See *recoverable virtual shared disk*.

**SAN.** See *storage area network*.

**SATA.** See *serial ATA*.

**scope.** Defines a group of controllers by their Internet Protocol (IP) addresses. A scope must be created and defined so that dynamic IP addresses can be assigned to controllers on the network.

**SCSI.** See *small computer system interface*.

**segmented loop port (SL\_port).** A port that allows division of a fibre-channel private loop into multiple segments. Each segment can pass frames around as an independent loop and can connect through the fabric to other segments of the same loop.

**sense data.** (1) Data sent with a negative response, indicating the reason for the response. (2) Data describing an I/O error. Sense data is presented to a host system in response to a sense request command.

**serial ATA.** The standard for a high-speed alternative to small computer system interface (SCSI) hard drives. The SATA-1 standard is equivalent in performance to a 10 000 RPM SCSI drive.

**serial storage architecture (SSA).** An interface specification from IBM in which devices are arranged in a ring topology. SSA, which is compatible with small computer system interface (SCSI) devices, allows full-duplex packet multiplexed serial data transfers at rates of 20 Mbps in each direction.

**server.** A functional hardware and software unit that delivers shared resources to workstation client units on a computer network.



**server/device events.** Events that occur on the server or a designated device that meet criteria that the user sets.

**SFP.** See *small form-factor pluggable*.

**Simple Network Management Protocol (SNMP).** In the Internet suite of protocols, a network management protocol that is used to monitor routers and attached networks. SNMP is an application layer protocol. Information on devices managed is defined and stored in the application's Management Information Base (MIB).

**SL\_port.** See *segmented loop port*.

**SMagent.** The FAStT Storage Manager optional Java-based host-agent software, which can be used on Microsoft Windows, Novell NetWare, HP-UX, and Solaris host systems to manage storage subsystems through the host fibre-channel connection.

**SMclient.** The FAStT Storage Manager client software, which is a Java-based graphical user interface (GUI) that is used to configure, manage, and troubleshoot storage servers and expansion units in a FAStT storage subsystem. SMclient can be used on a host system or on a storage management station.

**SMruntime.** A Java compiler for the SMclient.

**SMutil.** The FAStT Storage Manager utility software that is used on Microsoft Windows, HP-UX, and Solaris host systems to register and map new logical drives to the operating system. In Microsoft Windows, it also contains a utility to flush the cached data of the operating system for a particular drive before creating a FlashCopy.

**small computer system interface (SCSI).** A standard hardware interface that enables a variety of peripheral devices to communicate with one another.

**small form-factor pluggable (SFP).** An optical transceiver that is used to convert signals between optical fiber cables and switches. An SFP is smaller than a gigabit interface converter (GBIC). See also *gigabit interface converter*.

**SNMP.** See *Simple Network Management Protocol* and *SNMPv1*.

**SNMP time-out.** The maximum amount of time the SANavigator tool will wait for a device to respond to a request. The specified time applies to one retry only.

**SNMP trap event.** (1) (2) An event notification sent by the SNMP agent that identifies conditions, such as thresholds, that exceed a predetermined value. See also *Simple Network Management Protocol*.

**SNMPv1.** The original standard for SNMP is now referred to as SNMPv1, as opposed to SNMPv2, a revision of SNMP. See also *Simple Network Management Protocol*.

**SRAM.** See *static random access memory*.

**SSA.** See *serial storage architecture*.

**static random access memory (SRAM).** Random access memory based on the logic circuit known as flip-flop. It is called static because it retains a value as long as power is supplied, unlike dynamic random access memory (DRAM), which must be regularly refreshed. It is however, still volatile, meaning that it can lose its contents when the power is turned off.

**storage area network (SAN).** A dedicated storage network tailored to a specific environment, combining servers, storage products, networking products, software, and services. See also *fabric*.

**storage management station.** A system that is used to manage the storage subsystem. A storage management station does not need to be attached to the storage subsystem through the fibre-channel input/output (I/O) path.

**storage partition.** Storage subsystem logical drives that are visible to a host computer or are shared among host computers that are part of a host group.

**storage partition topology.** In the FAStT Storage Manager client, the Topology view of the Mappings window displays the default host group, the defined host group, the host computer, and host-port nodes. The host port, host computer, and host group topological elements must be defined to grant access to host computers and host groups using logical drive-to-LUN mappings.

**subnet.** An interconnected but independent segment of a network that is identified by its Internet Protocol (IP) address.

**sweep method.** A method of sending Simple Network Management Protocol (SNMP) requests for information to all the devices on a subnet by sending the request to every device in the network.

**switch.** A fibre-channel device that provides full bandwidth per port and high-speed routing of data by using link-level addressing.

**switch group.** A switch and the collection of devices connected to it that are not in other groups. Switch groups are discovered by the SANavigator tool and displayed with a gray background on the Physical and Data Path maps.

**system name.** Device name assigned by the vendor's third-party software.

**TCP.** See *Transmission Control Protocol*.

**TCP/IP.** See *Transmission Control Protocol/Internet Protocol*.

**terminate and stay resident program (TSR program).** A program that installs part of itself as an extension of DOS when it is executed.

**topology.** The physical or logical arrangement of devices on a network. The three fibre-channel topologies are fabric, arbitrated loop, and point-to-point. The default topology for the disk array is arbitrated loop.

**TL\_port.** See *translated loop port*.

**transceiver.** A device that is used to transmit and receive data. Transceiver is an abbreviation of transmitter-receiver.

**translated loop port (TL\_port).** A port that connects to a private loop and allows connectivity between the private loop devices and off loop devices (devices not connected to that particular TL\_port).

**Transmission Control Protocol (TCP).** A communication protocol used in the Internet and in any network that follows the Internet Engineering Task Force (IETF) standards for internetwork protocol. TCP provides a reliable host-to-host protocol between hosts in packed-switched communication networks and in interconnected systems of such networks. It uses the Internet Protocol (IP) as the underlying protocol.

**Transmission Control Protocol/Internet Protocol (TCP/IP).** A set of communication protocols that provide peer-to-peer connectivity functions for both local and wide-area networks.

**trap.** In the Simple Network Management Protocol (SNMP), a message sent by a managed node (agent function) to a management station to report an exception condition.

**trap recipient.** Receiver of a forwarded Simple Network Management Protocol (SNMP) trap. Specifically, a trap receiver is defined by an Internet Protocol (IP) address and port to which traps are sent. Presumably, the actual recipient is a software application running at the IP address and listening to the port.

**TSR program.** See *terminate and stay resident program*.

**uninterruptible power supply.** A source of power from a battery that is installed between a computer system and its power source. The uninterruptible power supply keeps the system running if a commercial power failure occurs, until an orderly shutdown of the system can be performed.

**user action events.** Actions that the user takes, such as changes in the storage area network (SAN), changed settings, and so on.

**vendor.** Property value that the SANavigator tool uses to launch third-party software. Vendor property might be discovered, but will always remain editable.

**worldwide name (WWN).** A unique identifier for a switch on local and global networks.

**WORM.** See *write-once read-many*.

**write-once read many (WORM).** Any type of storage medium to which data can be written only a single time, but can be read from any number of times. After the data is recorded, it cannot be altered.

**WWN.** See *worldwide name*.

**zoning.** A function that allows segmentation of nodes by address, name, or physical port and is provided by fabric switches or hubs.

---

# Index

## A

- about this document xvii
- ac power connector 6
- acoustical noise emission values 11
- Activity LED 5
- airflow 12

## B

- back view 3
- bays
  - hot-swap drive 3
  - hot-swap ESM 4
  - hot-swap fan 4
  - hot-swap power supply 4
- blank tray 5

## C

- cabling
  - a FAStT EXP100 to a FAStT600 38
  - a FAStT EXP100 to a FAStT900 39
  - a fibre-channel loop 31
  - an IBM FAStT EXP100 35
  - an IBM FAStT600 35
  - an IBM FAStT900 35
  - device overview 38
  - drive loop 42
  - fibre-channel restrictions 31
  - for power 32
  - SFP modules 31
  - the power supply 43
- Class A electronic emission notice 86
- comments, how to send xxiv
- components
  - environmental services monitors 2
  - fan units 2
  - FAStT 1.5 Gbps SATA hard disk drives 2
  - power supplies 2
- Concepts Guide xx
- controls, front 5
- cooling 12
- Copy Services Guide xx
- customer replaceable units (CRUs) 2
  - ESM 3
  - fan unit 3
  - hot-swap power supply, working with 54
  - power supply 3
  - removing a fan unit 23, 24
  - removing a hard disk drive 25
  - removing a power supply 23, 24
  - removing an ESM 23
  - removing hard disk drives 23

## D

- documentation
  - FAStT xviii
  - FAStT Storage Manager Version 8.4 xx
  - related xxii
- drive
  - amber Fault LED 3
  - blank tray 5
  - FAStT 1.5 Gbps SATA 3
  - green Activity LED 3
  - trays 3
- drive, hard disk
  - replacing all at same time 50, 51
  - replacing one at a time 50, 53

## E

- EIA 310-D Type A 19-inch rack cabinet 20
- electrical input 11
- electronic emission Class A notice 86
- Electronic emission notices
  - Australia and New Zealand Class A statement 87
  - European Union EMC Directive conformance statement 87
  - Federal Communications Commission (FCC) statement 86
  - Industry Canada Class A emission compliance statement 87
  - Japanese Voluntary Control Council for Interference (VCCI) statement 88
  - Taiwanese Class A warning statement 88
  - United Kingdom telecommunications safety requirement 87
- enclosure ID
  - switch setting 30
  - switch X1, setting the 30
  - switch X10, setting the 30
  - switch, described 8
- environment 11
- environmental services monitor (ESM) 2
  - description 7
  - Fault LED 8
  - input/output bypass LED 8
  - latch 4, 8
  - levers 8
  - over-temperature LED 8
  - power LED 8
  - SFP input/output ports 8
  - SFP module ports, cabling 31
- ESM failover
  - architecture 71
  - configuration guidelines 73
- expansion unit
  - cabling 31
  - identification numbers 77
  - performing an emergency shutdown 45
  - records 77

expansion unit (*continued*)  
restoring power after an emergency 46  
startup sequence 43  
turn on and turn off the 43  
turning on before storage server 43, 52

## F

fan CRU  
bay 4  
Fault LED 7  
latch 4  
latch and handle 7  
FASTT controller firmware 65  
FASTT documentation xviii  
FASTT EXP100 Expansion Unit library xx  
FASTT Storage Manager  
related documents xxii  
Version 8.4 Library xx  
FASTT Storage Manager 8.4  
user tasks xx  
FASTT600 FC Storage Server library xix  
FASTT900 FC Storage Server library xix  
Fault LED, ESM 8  
Fault LED, hard disk drive 5  
Fault LED, power supply 6  
FCC Class A notice 86  
fiber-optic cable, handling 35  
Fibre Channel defined 1  
fibre-channel loop 31  
adding the FASTT EXP100 42  
fibre-channel loop ID  
midplane 30  
setting 30  
fibre-channel loop IDs 48  
fire suppression xxiv  
firmware  
upgrading 65  
front indicators  
Activity LED 5  
Fault LED 5  
general system error LED 5  
power on LED 5

## H

handling static-sensitive devices 16  
hard disk drive  
replacing all at same time 50, 51  
replacing one at a time 50, 53  
hardware service and support xxiv  
heat dissipation 11  
heat output 12  
hot swap  
drive Activity LED 5  
drive bays 3  
drive CRU 5  
drive LED activity described 47  
environmental services monitors (ESMs) 5  
fan bays 4  
fan CRU 5, 7

hot swap (*continued*)  
hardware 48  
power supply bay 4  
power supply controls, indicators, and connectors 5  
power supply CRU 5, 6  
power supply CRU location 6

## I

IBM TotalStorage FASTT EXP100  
Activity LED 5  
components 2  
drive latches 5  
enclosure ID switches 8  
environmental services monitor location 7  
fan controls and indicators 6  
Fault LED 5  
front controls 5  
general system error LED 5  
hot-swap bays, location of 3  
hot-swap CRU bays 3  
hot-swap drive CRU 5  
installing into a rack cabinet 15  
introduction 1  
inventory checklist 2  
loop redundancy 31  
mounting in a rack 18  
operating specifications 10  
power on LED 5  
preparing for installation 16, 23  
RAID controllers 31  
rear controls, indicators and connectors 5  
removing CRUs 23  
site preparation 17  
size of 11  
speed settings, setting the 8, 31  
tray handle 5  
unpacking the 17  
user controls 7  
weight 11  
indicators 5  
input/output bypass LED 8  
installation  
into a rack cabinet 15  
installing  
hot-swap hard disk drives 48  
installing and replacing devices  
blank trays 47  
hot-swap hard disk drives 47  
inventory checklist 2

## L

latch, hard disk drive 5  
LC-LC fibre-channel cable 35  
removing 37  
using the 35  
LED  
amber drive fault 5  
amber ESM fault 8  
amber ESM input/output 8

LED (*continued*)  
  amber ESM over temperature 8  
  amber power supply fault 5, 6  
  general system error 5  
  green drive activity 5  
  green ESM power 8  
  green power 6  
  green power-on 5  
loop redundancy, described 40

## N

Netfinity FC Cabling Instructions xxii  
notes, important 86  
notices  
  electronic emission 86  
  FCC, Class A 86  
  used in this book iii  
Notices  
  trademarks 85

## O

over-temperature LED 8

## P

power cabling 32  
power cords 83  
power LED 6, 8  
power supply 5  
  ac power connector location 6  
  Fault LED 5, 6  
  lever 4  
  lever location 6  
  levers 6  
  power LED location 6  
  power switch location 6  
power switch 6  
problem determination 61

## R

rack cabinet  
  EIA 310-D Type A 19 inch 20  
  preparatory procedures 18  
  rail installation 20  
  site preparation 16  
rack mounting template for FAStT EXP100 18, 79  
rear indicators  
  Fault LED 5, 6  
  power LED 6  
redundant power supply 5  
replacing  
  a failed hot-swap ESM 57  
  a failed hot-swap fan unit 58  
  a failed hot-swap power supply 55  
  a hot-swap hard disk drive 49  
replacing CRUs  
  ESM 27

replacing CRUs (*continued*)  
  fan unit 28  
  hot-swap hard disk drives 29  
  power supply 27  
restrictions  
  fibre-channel cable 31

## S

safety information iii  
Safety Information xxii  
SATA defined 2  
Script Commands xx  
setting interface options 29  
SFP modules  
  removing 34  
small form-factor pluggable module (SFP)  
  connecting to an LC-LC fibre-channel cable 36  
  description 8  
  important information about 32  
  location 8  
  port location, FAStT EXP100 39  
  port location, FAStT900 39  
  protective cap 33  
  removing an LC-LC cable 37  
  static-protective package 33  
software service and support xxiii  
specifications 11  
storage manager software and hardware  
  compatibility 9

## T

tasks by documentation title xviii  
trademarks 85  
tray handle, hard disk drive 5  
troubleshooting 61

## U

United States electronic emission Class A notice 86  
United States FCC Class A notice 86  
user tasks  
  FAStT EXP100 Expansion Unit library xx  
  FAStT Storage Manager xx  
  FAStT600 Fibre Channel Storage Server xix  
  FAStT900 Fibre Channel Storage Server xix  
  related documents xxii

## W

web sites, related xxiii



---

# Readers' Comments — We'd Like to Hear from You

IBM TotalStorage FAStT EXP100  
Storage Expansion Unit  
Installation and User's Guide

Publication No. GC26-7601-00

Overall, how satisfied are you with the information in this book?

	Very Satisfied	Satisfied	Neutral	Dissatisfied	Very Dissatisfied
Overall satisfaction	<input type="checkbox"/>	<input type="checkbox"/>	<input type="checkbox"/>	<input type="checkbox"/>	<input type="checkbox"/>

How satisfied are you that the information in this book is:

	Very Satisfied	Satisfied	Neutral	Dissatisfied	Very Dissatisfied
Accurate	<input type="checkbox"/>	<input type="checkbox"/>	<input type="checkbox"/>	<input type="checkbox"/>	<input type="checkbox"/>
Complete	<input type="checkbox"/>	<input type="checkbox"/>	<input type="checkbox"/>	<input type="checkbox"/>	<input type="checkbox"/>
Easy to find	<input type="checkbox"/>	<input type="checkbox"/>	<input type="checkbox"/>	<input type="checkbox"/>	<input type="checkbox"/>
Easy to understand	<input type="checkbox"/>	<input type="checkbox"/>	<input type="checkbox"/>	<input type="checkbox"/>	<input type="checkbox"/>
Well organized	<input type="checkbox"/>	<input type="checkbox"/>	<input type="checkbox"/>	<input type="checkbox"/>	<input type="checkbox"/>
Applicable to your tasks	<input type="checkbox"/>	<input type="checkbox"/>	<input type="checkbox"/>	<input type="checkbox"/>	<input type="checkbox"/>

Please tell us how we can improve this book:

Thank you for your responses. May we contact you?  Yes  No

When you send comments to IBM, you grant IBM a nonexclusive right to use or distribute your comments in any way it believes appropriate without incurring any obligation to you.

---

Name

---

Address

---

Company or Organization

---

Phone No.



Fold and Tape

Please do not staple

Fold and Tape



NO POSTAGE  
NECESSARY  
IF MAILED IN THE  
UNITED STATES

# BUSINESS REPLY MAIL

FIRST-CLASS MAIL PERMIT NO. 40 ARMONK, NEW YORK

POSTAGE WILL BE PAID BY ADDRESSEE

International Business Machines Corporation  
RCF Processing Department  
Dept. FTFA/Bldg.050-1  
5600 Cottle Road  
San Jose, CA  
U.S.A 95193-0001



Fold and Tape

Please do not staple

Fold and Tape







Part Number: 24P8385

Printed in USA

GC26-7601-00



(1P) P/N: 24P8385

