



# Planning Guide





IBM NetBAY Rack



# Planning Guide

**NOTE**

Before using this information and the product it supports, be sure to read the general information in Appendix C, "Product notices," on page 25.

**First Edition (April 2001)**

**© Copyright International Business Machines Corporation 2001. All rights reserved.**

US Government Users Restricted Rights – Use, duplication or disclosure restricted by GSA ADP Schedule Contract with IBM Corp.

## **Safety**

Before installing this product, read the Safety Information book.

مح، يجب قراءة دات السلامة

Antes de instalar este produto, leia o Manual de Informações sobre Segurança.

安装本产品前请先阅读《安全信息》手册。

Před instalací tohoto produktu si přečtete příručku bezpečnostních instrukcí.

Læs hæftet med sikkerhedsforskrifter, før du installerer dette produkt.

Lue Safety Information -kirjanen, ennen kuin asennat tämän tuotteen.

Avant de procéder à l'installation de ce produit, lisez le manuel Safety Information.

Vor Beginn der Installation die Broschüre mit Sicherheitshinweisen lesen.

Πριν εγκαταστήσετε αυτό το προϊόν, διαβάστε το εγχειρίδιο Safety Information.

Prije instalacije ovog proizvoda pročitajte priručnik sa sigurnosnim uputama.

לפני שתתקינו מוצר זה, קראו את הוראות הבטיחות.

Przed zainstalowaniem tego produktu należy przeczytać broszurę Informacje Dotyczące Bezpieczeństwa.

Prima di installare questo prodotto, leggere l'opuscolo contenente le informazioni sulla sicurezza.

本製品を導入する前に、安全情報資料を御読みください。

이 제품을 설치하기 전에, 안전 정보 책자를 읽어보십시오.

Пред да го инсталирате овој производ прочитајте ја книгата со безбедносни информации.

Lees voordat u dit product installeert eerst het boekje met veiligheidsvoorschriften.

Les heftet om sikkerhetsinformasjon (Safety Information) før du installerer dette produktet.

Antes de instalar este produto, leia o folheto Informações sobre Segurança.

Перед установкой продукта прочтите брошюру по технике безопасности (Safety Information).

Pred inštaláciou tohto produktu si prečítajte Informačnú brožúrku o bezpečosti.

Preden namestite ta izdelek, preberite knjižico Varnostne informacije.

Antes de instalar este producto, lea la Información de Seguridad.

Läs säkerhetsinformationen innan du installerar den här produkten.

在安裝本產品之前，也請先閱讀「安全性資訊」小冊子。

Installálás el tt olvassa el a Biztonsági el írások kézikönyvét !

**Important:**

All caution and danger statements in this documentation begin with a number. This number is used to cross reference an English caution or danger statement with translated versions of the caution or danger statement in the *IBM NetBAY Rack Safety Information* book available on the IBM Web site.

For example, if a caution statement begins with a number 1, translations for that caution statement appear in the *IBM NetBAY Rack Safety Information* book under statement 1.

Be sure to read all caution and danger statements before performing the instructions.

1



**CAUTION:**

To ensure safety, all configurations of the rack must be Listed in the U.S.A. and Certified in Canada by a nationally recognized testing laboratory such as Underwriters Laboratory (UL), Canadian Standards Association (CSA), or ETL Testing Laboratories.

2



**DANGER**

- The maximum allowable weight for devices on slides is 80 kg (176 lb). Do not install sliding devices exceeding this weight.
- The center of gravity for an extended unit cannot exceed 407 mm (16 in.) from the face of the rack. If an extended device exceeds this distance, the configured rack might be unstable.

3



**DANGER**

- Always install servers and power devices in the rack from the bottom to the top.
- Always install the heaviest equipment in the bottom of the rack.
- Always install the UPS (uninterruptible power supply) in the bottom of the rack.
- Always install the stabilizer bracket.
- Do not extend more than one sliding device at a time.

4



**DANGER**

Plug rack power cords into electrical outlets that are located near the rack and are easily accessible.

5



**DANGER**

Each rack might have more than one power cord. Be sure to disconnect all power cords in the rack before servicing any device in the rack.



6



**DANGER**

Install an emergency power off (EPO) switch if more than one power device (power distribution unit or uninterruptible power supply) is installed in one rack.

7



**DANGER**

Connect all devices installed in a rack to power devices installed in the same rack. Do not plug the power cord from a device installed in one rack into a power device installed in a different rack.

8



**CAUTION:**

**Removing components from the upper rack positions improves rack stability during relocation. Follow these general guidelines whenever you relocate a populated rack within a room or building:**

- **Reduce the weight of the rack by removing equipment starting at the top of the rack. When possible, restore the rack to the configuration of the rack cabinet as you received it. If this is not possible or this configuration is not known, remove all devices in the 32U position and above before moving the rack.**
- **Inspect the route that you plan to take to eliminate potential hazards.**
- **Verify that the route that you choose can support the weight of the loaded rack, which can be up to 930 kg (2045 lb).**
- **Verify that all door openings are at least a standard 760 x 2030 mm (30 x 80 in.) size.**
- **Ensure that all devices, drawers, doors, and cables are secure.**
- **Ensure that the four levelling pads are raised to their highest position.**
- **Ensure that the stabilizer bracket is removed.**
- **Do not use a ramp inclined at more than ten degrees.**
- **Once the rack is in its new location, repopulate the rack from the lowest position to the highest position.**

**If a long distance relocation is required, pack the rack in the original packaging material, or equivalent. Also, lower the levelling pads to raise the casters off of the pallet and bolt the rack to the pallet**

# Contents

<b>Safety</b> .....	iii
<b>Figures</b> .....	xi
<b>Chapter 1. Introduction</b> .....	1
<b>Chapter 2. Planning for your rack cabinet</b> .....	3
Defining rack cabinet physical dimensions and clearances .....	4
Defining rack cabinet electrical requirements .....	7
Defining rack cabinet optional device limitations .....	8
<b>Chapter 3. Preparing a location for the rack cabinet.</b> .....	11
Creating a floor plan .....	12
Moving your rack cabinet .....	13
<b>Chapter 4. Installing optional devices</b> .....	15
Using the rack cabinet mounting flanges .....	16
Installing threaded rails or bars .....	16
Installing clip nuts .....	17
<b>Appendix A. Optional device specifications</b> .....	19
NetBAY console switches .....	19
NetBAY rack power distribution units .....	20
<b>Appendix B. Getting help, service, and information</b> .....	23
<b>Appendix C. Product notices.</b> .....	25
Notices .....	25
Edition notice .....	25
Processing date data .....	26
Trademarks .....	26
Important notes .....	26



## **Figures**

1. NetBAY42 Enterprise Rack cabinet with and without side panels .....	1
2. Providing service clearance for the NetBAY42 Enterprise Rack cabinet .....	4
3. Providing operational clearance for the NetBAY42 Enterprise Rack cabinet.....	5
4. Leaving space between rack cabinet suites.....	5
5. Measuring inside of the NetBAY42 Enterprise Rack cabinet .....	6
6. Measuring U levels within the rack cabinet .....	6
7. Installing optional devices in the NetBAY42 Enterprise Rack cabinet.....	15
8. Installing clip nuts on the rack mounting flanges.....	17



## Chapter 1. Introduction

This documentation contains information that will help you plan for your IBM® NetBAY Rack cabinet and optional device installation. Always refer to the documentation that comes with your server or optional device as well as the documentation that comes with your rack cabinet for detailed installation instructions. Also refer to the unpacking instructions for your rack cabinet for how to unpack and locate your rack cabinet.

The primary NetBAY42 Enterprise Rack cabinet comes with side panels installed. You will need one primary rack cabinet per suite. The expansion NetBAY42 Enterprise Rack cabinet comes without side panels, and includes the required hardware for attaching rack cabinets together to form a suite.

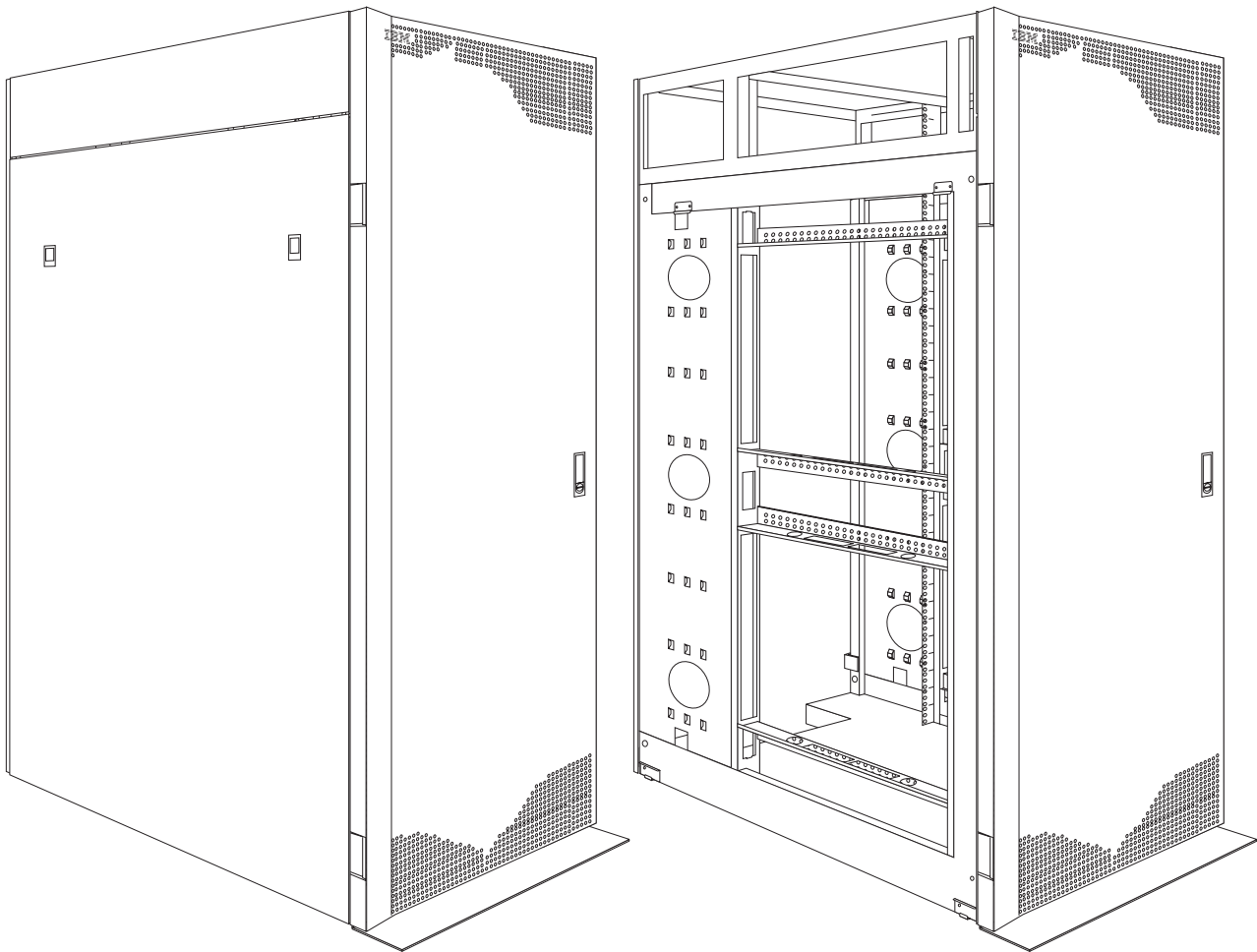

Figure 1. NetBAY42 Enterprise Rack cabinet with and without side panels

**Note:** The illustrations in this documentation might be slightly different from your hardware.





---

## Chapter 2. Planning for your rack cabinet

The Rack Configurator program is available from the IBM Web site to help you plan your rack cabinet and optional device installation. This program provides an intuitive graphical interface to help you configure the rack cabinet and optional devices. The Rack Configurator program also provides the following information about your rack cabinet:

- Weight and stability limits
- Thermal and heat calculations
- Power requirements
- Internal space dimensions
- External space requirements
- Human factors considerations

1



**CAUTION:**

**To ensure safety, all configurations of the rack must be Listed in the U.S.A. and Certified in Canada by a nationally recognized testing laboratory such as Underwriters Laboratory (UL), Canadian Standards Association (CSA), or ETL Testing Laboratories.**

You can select components from the Component Catalog and place them in the Configuration Notebook to create a configuration. The Configuration Notebook also contains a parts list, specifications, and a top-view floor plan. You can then configure a single rack cabinet or a suite of rack cabinets.

Functions such as **Auto Arrange**, **Validate**, and **Build** ensure proper placement of optional devices within the rack cabinet. The Rack Configurator program guides you to connect optional devices and select the appropriate cables for connections. For additional assistance in creating a configuration, you can start **IBM ConfigPro** or **IBM Which Switch?** to configure individual devices.

## Defining rack cabinet physical dimensions and clearances

The weight of an empty NetBAY42 Enterprise Rack cabinet is 261 kg (575 lb). A fully loaded rack cabinet can weigh up to 928 kg (2045 lb). The physical dimensions of the NetBAY42 Enterprise Rack cabinet are 64.8 cm x 110.5 cm x 201.9 cm (25.5 in. x 43.5 in. x 79.5 in.). The NetBAY42 Enterprise Rack cabinet is an Electronic Industries Association (EIA) standard 42U rack cabinet.

The NetBAY42 Enterprise Rack cabinet requires a minimal operational clearance on all sides to ensure proper ventilation and access to open the front and rear doors. An extended service clearance also provides easier access to the rack cabinet so that you can install and service optional devices. See Figure 2 and Figure 3 on page 5 for illustrations of the service and operational clearances.

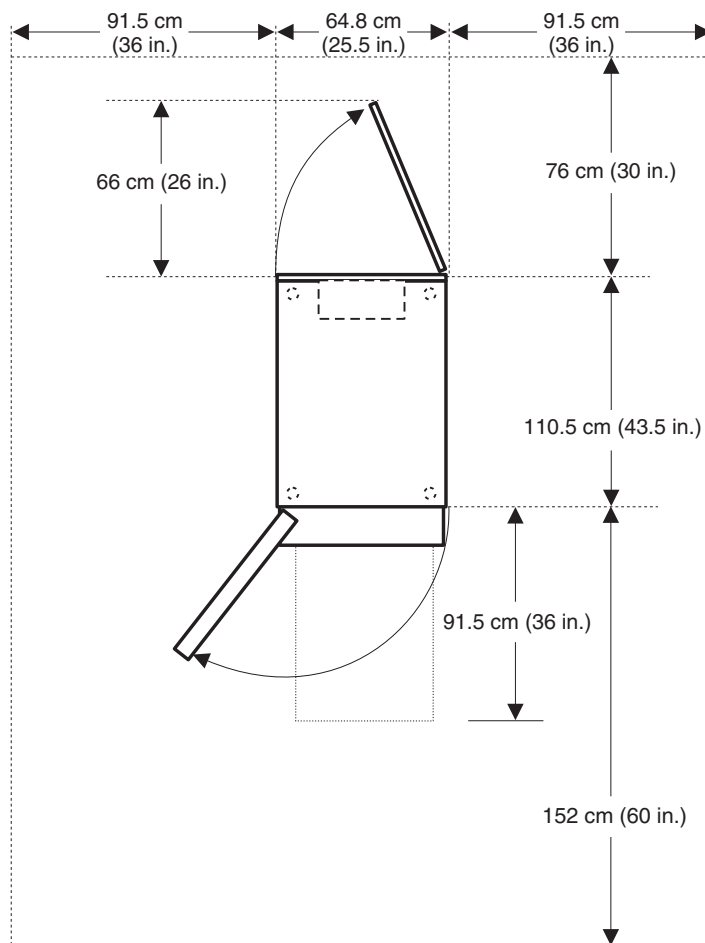

Figure 2. Providing service clearance for the NetBAY42 Enterprise Rack cabinet

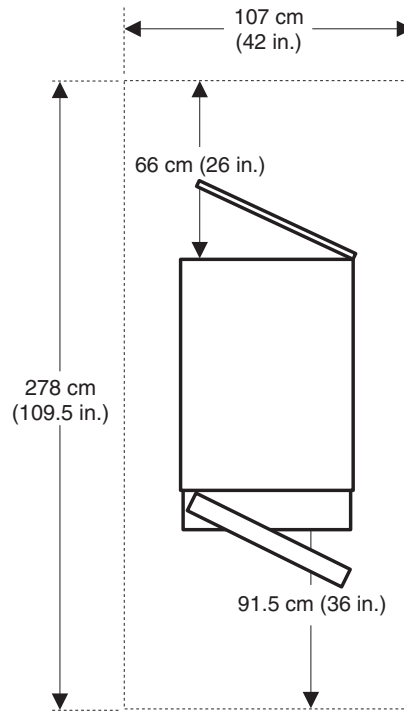

Figure 3. Providing operational clearance for the NetBAY42 Enterprise Rack cabinet

When you attach primary and expansion rack cabinets together to form a suite of rack cabinets, you must leave 152 cm (60 in.) between suites in the same room. This provides proper ventilation and allows access to install and service optional devices.

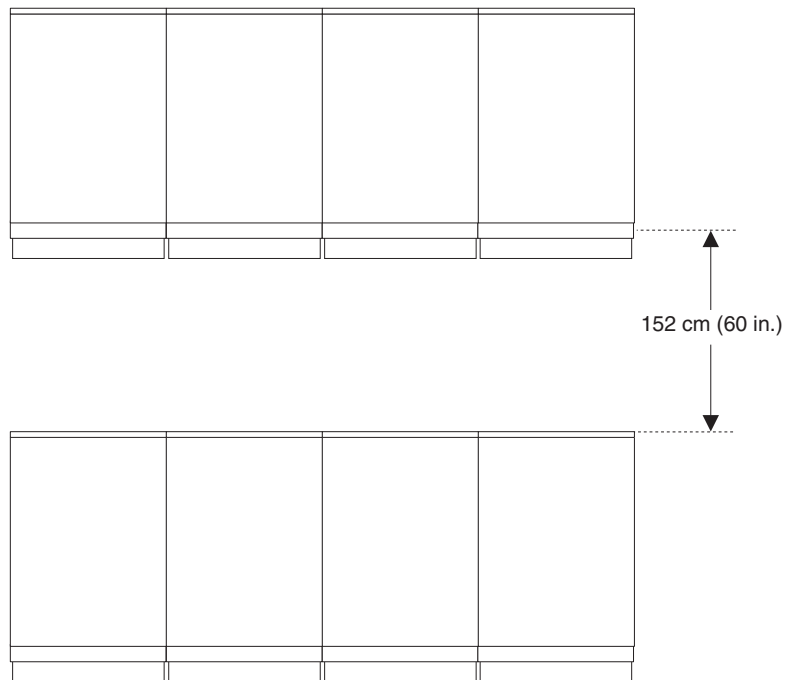

Figure 4. Leaving space between rack cabinet suites

The internal dimensions of the NetBAY42 Enterprise Rack cabinet conform to the EIA standard *EIA-310-D Cabinets, Racks, Panels, and Associated Equipment (1992)*. See Figure 5 for rack cabinet internal dimensions.

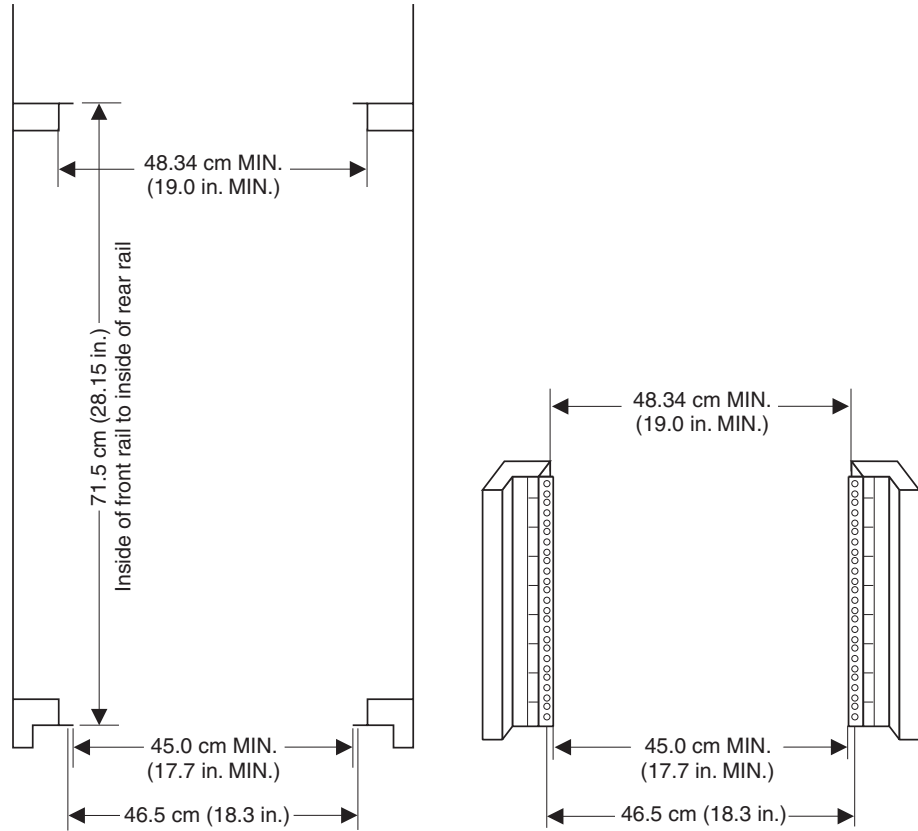

Figure 5. Measuring inside of the NetBAY42 Enterprise Rack cabinet

All vertical rack cabinet measurements are given in rack units (U), where 1U is equal to 4.45 cm (1.75 in.). The U levels are marked on labels on the front and rear mounting flanges inside of the rack cabinet, as shown in Figure 6.

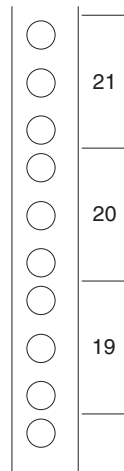

Figure 6. Measuring U levels within the rack cabinet

---

## Defining rack cabinet electrical requirements

The rack cabinet does not require electricity, but the servers and optional devices that you install inside of a rack cabinet do require connection to properly wired and grounded electrical outlets. You might need an electrician to assist you with planning for electrical requirements, such as:

- Each rack cabinet requires at least one uninterruptible power supply (UPS) or power distribution unit (PDU) for servers and optional devices that you install in the rack cabinet.
- Each PDU or UPS requires a separate ac power branch circuit.
- The input voltage-selection switch on each device that you install in your rack cabinet must match the output voltage on the UPS or PDU.
- Power cords must match electrical outlets at the location where you install your rack cabinet.

Use the following additional guidelines when you plan for your rack cabinet:

4



### **DANGER**

**Plug rack power cords into electrical outlets that are located near the rack and are easily accessible.**

5



### **DANGER**

**Each rack might have more than one power cord. Be sure to disconnect all power cords in the rack before servicing any device in the rack.**

6



**DANGER**

Install an emergency power off (EPO) switch if more than one power device (power distribution unit or uninterruptible power supply) is installed in one rack.

7



**DANGER**

Connect all devices installed in a rack to power devices installed in the same rack. Do not plug the power cord from a device installed in one rack into a power device installed in a different rack.

---

## Defining rack cabinet optional device limitations

As you prepare the physical site for the rack cabinet, be aware of its limitations. This is especially important if you plan to install non-IBM equipment in the rack cabinet. The rack cabinet has been tested under certain conditions for stability and safety. Be sure that the rack cabinet and optional devices you install meet these requirements:

2



**DANGER**

- The maximum allowable weight for devices on slides is 80 kg (176 lb). Do not install sliding devices exceeding this weight.
- The center of gravity for an extended unit cannot exceed 407 mm (16 in.) from the face of the rack. If an extended device exceeds this distance, the configured rack might be unstable.

3



**DANGER**

- **Always install servers and power devices in the rack from the bottom to the top.**
  - **Always install the heaviest equipment in the bottom of the rack.**
  - **Always install the UPS (uninterruptible power supply) in the bottom of the rack.**
  - **Always install the stabilizer bracket.**
  - **Do not extend more than one sliding device at a time.**
- 
- The maximum weight of a fully loaded rack cabinet is 928 kg (2045 lb).
  - The weight of devices that you install on the four corner posts of the rack cabinet must not exceed 16 kg (35 lb) per U level; cantilevered devices must not exceed 5 kg (11 lb) per U level.





---

## Chapter 3. Preparing a location for the rack cabinet

Before you unpack or install a rack cabinet, be sure that you:

- Understand the rack cabinet specifications and requirements
- Prepare a layout for the rack cabinet or suite of rack cabinets
- Prepare the physical site (location) where you will install the rack cabinet
- Read the unpacking instructions and *Installation Guide* that come with your rack cabinet

Physical site planning includes determining the:

- Floor area that is required by the equipment
- Floor-load capacity
- Space that is needed for future expansion
- Location of columns or other unmovable building structures
- Power and environmental requirements

Create a floor plan to check for clearance problems. Make a full-scale template, if needed, of the rack cabinet and carry it along the access route to check for potential clearance problems through doorways and passageways, around corners, and in elevators.

**Note:** Some rack cabinets might have removable parts that can be temporarily removed so that the rack cabinet can be moved through some nonstandard doorways, if required. Refer to the *Installation Guide* for your rack cabinet for additional information.

Remember to also provide space for storage cabinets, card files, desks, communication facilities, daily storage of tapes, and other supplies.

---

## Creating a floor plan

To be sure that you have enough space for the rack cabinet or suite of rack cabinets, create a floor plan before installing any rack cabinets. You might need to prepare and analyze several plans before choosing a final one. If you install more than one rack cabinet in more than one installation stage, prepare a separate plan for each installation stage. Consider all of the following when you prepare each plan:

- Flow of work and personnel within the area
- Operator access to units, as required
- If the placement will be on a raised floor:
  - Positioning over a cooling register
  - Leaving the bottom of the rack cabinet open to facilitate cooling
- If the placement will not be on a raised floor:
  - Maximum cable lengths
  - Need for cable guards, ramps, or other similar items to protect equipment and personnel
- Location of any planned safety equipment
- Future expansion

Begin with an accurate drawing of the installation area (blueprints and floor plans are appropriate). Be sure to include the following in your floor plan:

- Service clearances that are required for each rack cabinet or suite of rack cabinets
- If the placement will be on a raised floor:
  - Things that might obstruct cable routing
  - The height of the raised floor
- If the placement will not be on a raised floor:
  - The placement of cables to minimize obstruction
  - If the cable routing is indirectly between rack cabinets, such as along walls or suspended from the ceiling, the amount of additional cable that is required
- Location of:
  - Power receptacles
  - Air conditioning equipment and controls
  - File cabinets, desks, and other office equipment
  - Room emergency power-off controls
  - All entrances, exits, windows, columns, and pillars

Review the final floor plan to ensure that cable lengths are not too long and that the rack cabinets have enough clearance. Refer to the *Installation Guide* for your rack cabinet for additional information.

---

## Moving your rack cabinet

The fully populated NetBAY42 Enterprise Rack cabinet has been evaluated and found to meet UL-1950, CSA-950, and IEC-950 stability test standards. Since these standards apply only to a rack cabinet in an installed location, IBM enforces additional standards to ensure stability when rolling the rack cabinet on its casters.

You can move a rack cabinet as long as you adhere to the following standards:

5



### DANGER

Each rack might have more than one power cord. Be sure to disconnect all power cords in the rack before servicing any device in the rack.

8



### CAUTION:

Removing components from the upper rack positions improves rack stability during relocation. Follow these general guidelines whenever you relocate a populated rack within a room or building:

- Reduce the weight of the rack by removing equipment starting at the top of the rack. When possible, restore the rack to the configuration of the rack cabinet as you received it. If this is not possible or this configuration is not known, remove all devices in the 32U position and above before moving the rack.
- Inspect the route that you plan to take to eliminate potential hazards.
- Verify that the route that you choose can support the weight of the loaded rack, which can be up to 930 kg (2045 lb).
- Verify that all door openings are at least a standard 760 x 2030 mm (30 x 80 in.) size.
- Ensure that all devices, drawers, doors, and cables are secure.
- Ensure that the four levelling pads are raised to their highest position.
- Ensure that the stabilizer bracket is removed.
- Do not use a ramp inclined at more than ten degrees.
- Once the rack is in its new location, repopulate the rack from the lowest position to the highest position.

If a long distance relocation is required, pack the rack in the original packaging material, or equivalent. Also, lower the levelling pads to raise the casters off of the pallet and bolt the rack to the pallet.



## Chapter 4. Installing optional devices

There are many servers and optional devices that you can install in your rack cabinet. Always read the documentation that comes with your server or optional device for detailed installation instructions.

**Note:** You can install many optional devices using the general instructions provided in the rack cabinet *Installation Guide*. Some devices might require the detailed installation information contained in the documentation that comes with the optional device.

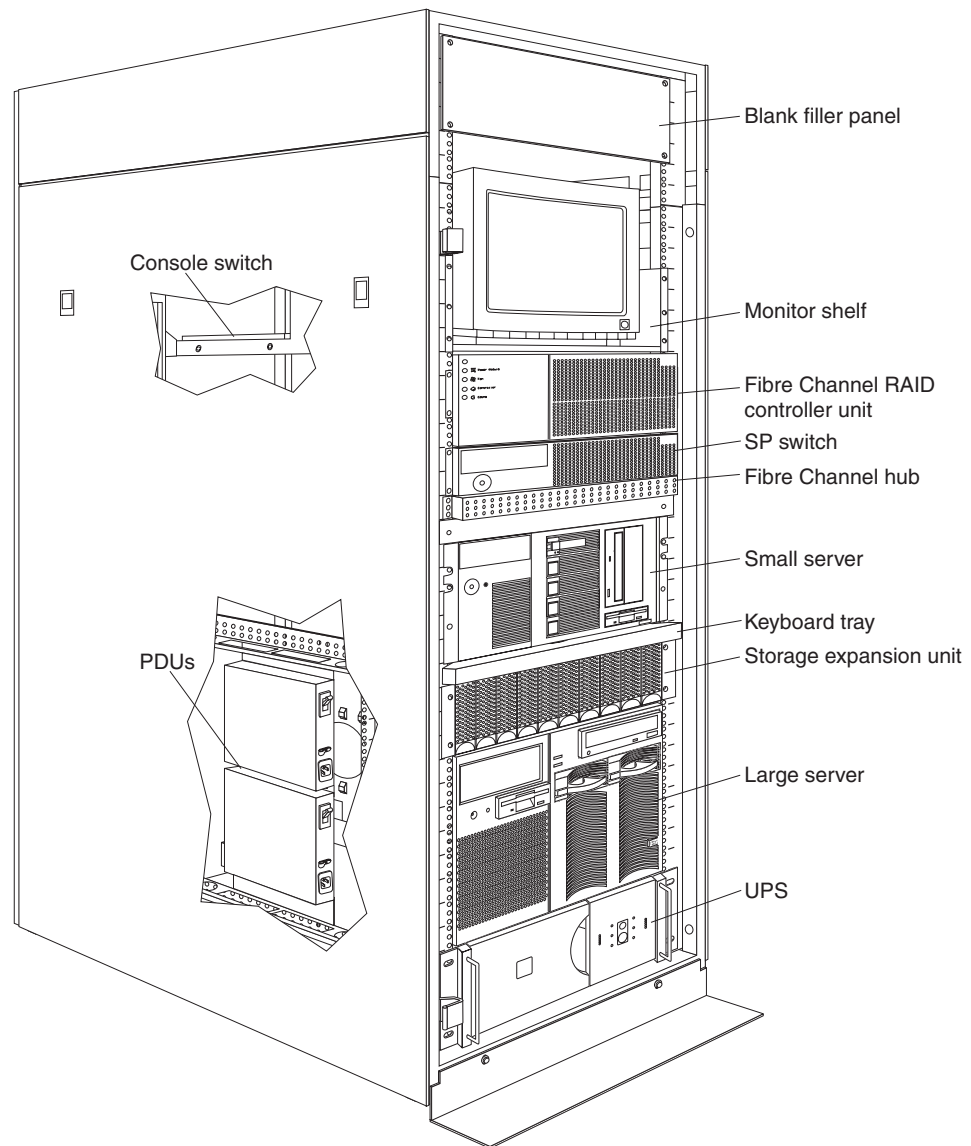

Figure 7. Installing optional devices in the NetBAY42 Enterprise Rack cabinet

---

## Using the rack cabinet mounting flanges

When you install optional devices in the rack cabinet, you secure either the device or the rails for that device on the rack mounting flanges. Some devices come with threaded rails or threaded bars for the rails. Other devices require that you use clip nuts to install the device in your rack cabinet.

2



### DANGER

- **The maximum allowable weight for devices on slides is 80 kg (176 lb). Do not install sliding devices exceeding this weight.**
- **The center of gravity for an extended unit cannot exceed 407 mm (16 in.) from the face of the rack. If an extended device exceeds this distance, the configured rack might be unstable.**

3



### DANGER

- **Always install servers and power devices in the rack from the bottom to the top.**
- **Always install the heaviest equipment in the bottom of the rack.**
- **Always install the UPS (uninterruptible power supply) in the bottom of the rack.**
- **Always install the stabilizer bracket.**
- **Do not extend more than one sliding device at a time.**

## Installing threaded rails or bars

You must install devices or device rails that have threaded holes on the inside of the rack mounting flanges. You can, however, install devices or device rails that come with threaded bars on either the inside or the outside of the rack mounting flanges. See the device documentation for detailed information on how to use threaded bars.

## Installing clip nuts

You must use clip nuts for all optional devices that do not have threaded holes. Clip nuts install on the rack mounting flanges as shown in Figure 8. Some devices might require that you install the clip nuts on the rail instead of the rack mounting flanges. See the device documentation for information on where you must install the clip nuts.

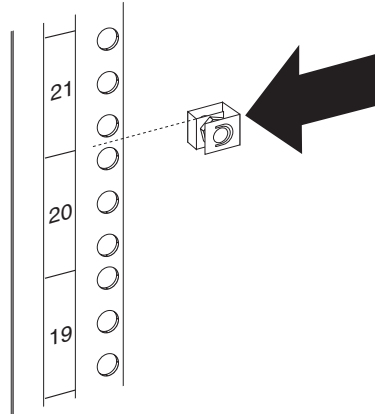

*Figure 8. Installing clip nuts on the rack mounting flanges*

**Note:** Your rack cabinet comes with a supply of clip nuts that you can use to install optional devices. Most devices will also come with clip nuts that you can use.





---

## Appendix A. Optional device specifications

This section contains specifications for some optional devices such as power distribution units (PDU) and console switches. Refer to the documentation that comes with your servers or optional devices for additional information.

---

### NetBAY console switches

The following table contains the product specifications for the NetBAY 1x4 Console Switch and the NetBAY 2x8 Console Switch:

*Table 1. NetBAY Console Switch specifications.*

	<b>1x4 Console Switch</b>	<b>2x8 Console Switch</b>
<b>Height</b>	4.3 cm (1.7 in.)	4.3 cm (1.7 in.)
<b>Depth</b>	20.3 cm (8.0 in.)	20.3 cm (8.0 in.)
<b>Width</b>	43.2 cm (17 in.)	43.2 cm (17 in.)
<b>Weight</b>	2.38 kg (5.25 lb)	2.59 kg (5.7 lb)
<b>Rated voltage</b>	100 – 240 V ac	100 – 240 V ac
<b>Rated frequency</b>	50 – 60 Hz	50 – 60 Hz
<b>Rated input current</b>	1.0 A maximum	1.0 A maximum
<b>Operating temperature at 0–914 m (0–3000 ft)</b>	10° – 35°C (50° – 95°F)	10° – 35°C (50° – 95°F)
<b>Operating temperature at 914–2133 m (3000–7000 ft)</b>	10° – 32°C (50° – 90°F)	10° – 32°C (50° – 90°F)
<b>Operating humidity (non-condensing)</b>	8% – 80%	8% – 80%
<b>Video modes supported</b>	VGA, SVGA, XGA	VGA, SVGA, XGA

## NetBAY rack power distribution units

The following tables contain product specifications for the NetBAY Rack PDU, NetBAY Server PDU, and NetBAY Front-end PDU:

Table 2. NetBAY Rack PDU specifications.

<b>Height</b>	43 mm (1.7 in.)
<b>Width</b>	192 mm (7.5 in.)
<b>Depth</b>	221 mm (8.7 in.)
<b>Weight</b>	1.5 kg (3.2 lb)
<b>Operating temperature at 0–914 m (0–3000 ft)</b>	10° – 35°C (50° – 95°F)
<b>Operating temperature at 914–2133 m (3000–7000 ft)</b>	10° – 32°C (50° – 90°F)
<b>Operating humidity (non-condensing)</b>	8% – 80%
<b>Rated voltage</b>	100 – 240 V ac, 15 A, single-phase
<b>Rated frequency</b>	50 – 60 Hz
<b>Maximum power rating</b>	3600 VA
<b>Circuit breaker</b>	Two-pole, 15 A with time-delay protection for up to 600 A input current without nuisance tripping.
<b>Power inlet</b>	IEC 320-C20 inlet rated at 16 A (VDE) / 20 A (UL/CSA)
<b>Power outlets</b>	Seven IEC 320-C13 outlets rated at 10 A (VDE) / 15 A (UL/CSA)

Table 3. NetBAY Server PDU specifications.

<b>Height</b>	43 mm (1.7 in.)
<b>Width</b>	192 mm (7.5 in.)
<b>Depth</b>	221 mm (8.7 in.)
<b>Weight</b>	2.4 kg (5.4 lb)
<b>Operating temperature at 0–914 m (0–3000 ft)</b>	10° – 35°C (50° – 95°F)
<b>Operating temperature at 914–2133 m (3000–7000 ft)</b>	10° – 32°C (50° – 90°F)
<b>Operating humidity (non-condensing)</b>	8% – 80%
<b>Rated voltage</b>	100 – 127 V ac, 15 A, single-phase 200 – 240 V ac, 10 A, single-phase
<b>Rated frequency</b>	50 – 60 Hz
<b>Maximum power rating</b>	2400 VA
<b>Power inlet</b>	Two IEC 320-C20 inlets rated at 16 A (VDE) / 20 A (UL/CSA)
<b>Transfer time</b>	< 35 ms from main to backup power
<b>Power outlets</b>	Four IEC 320-C13 outlets rated at 10 A (VDE) / 15 A (UL/CSA)

Table 4. NetBAY Front-end PDU specifications.

<b>Height</b>	43 mm (1.7 in.)
<b>Width</b>	192 mm (7.5 in.)
<b>Depth</b>	221 mm (8.7 in.)
<b>Weight</b>	1.6 kg (3.5 lb)
<b>Operating temperature at 0–914 m (0–3000 ft)</b>	10° – 35°C (50° – 95°F)
<b>Operating temperature at 914–2133 m (3000–7000 ft)</b>	10° – 32°C (50° – 90°F)
<b>Operating humidity (non-condensing)</b>	8% – 80%
<b>Rated voltage</b>	100 – 120 V ac, 30 A, single-phase 200 – 240 V ac, 30 A, single-phase 200 – 240 V ac, 32 A, single-phase 200 – 240 V ac, 30 A, three-phase 380 – 415 V ac, 32 A, three-phase
<b>Rated frequency</b>	50 – 60 Hz
<b>Maximum power rating</b>	4800-6000 VA
<b>Power inlet</b>	One fixed line cord
<b>Power outlets</b>	Three IEC 320-C19 outlets rated at 16 A (VDE) / 20 A (UL/CSA)



---

## Appendix B. Getting help, service, and information

If you need help, service, technical assistance, or just want more information about IBM products, you will find a wide variety of sources available from IBM to assist you.

With the original purchase of an IBM hardware product, you have access to extensive support coverage. During the IBM hardware product warranty period, you may call the IBM Personal Computer HelpCenter (1-800-772-2227 in the U.S.) for hardware product assistance covered under the terms of the IBM Statement of Limited Warranty.

The following services are available during the warranty period:

- Problem Determination - Trained personnel are available to assist you with determining if you have a hardware problem and deciding what action is necessary to fix the problem.
- IBM Hardware Repair - If the problem is determined to be caused by IBM hardware under warranty, trained service personnel are available to provide the applicable level of service.
- Engineering Change Management - Occasionally, there might be changes that are required after a product has been sold. IBM or your reseller, if authorized by IBM, will make Engineering Changes (ECs) available that apply to your hardware.

Be sure to retain your proof of purchase to obtain warranty service. Refer to the IBM hardware warranty for a full explanation of IBM warranty terms.

Please have the following information ready when you call:

- Machine type and model
- Serial numbers of your IBM hardware products
- Description of the problem
- Exact wording of any error messages
- Hardware and software configuration information

On the World Wide Web, the IBM Personal Computing Web site has up-to-date information about IBM Personal Computer products and support.

Some helpful addresses are:

*Table 5. IBM Personal Computing Web sites.*

<b>World Wide Web site URL</b>	<b>Description</b>
<a href="http://www.ibm.com">http://www.ibm.com</a>	Main IBM home page
<a href="http://www.ibm.com/pc">http://www.ibm.com/pc</a>	IBM Personal Computing
<a href="http://www.ibm.com/pc/support">http://www.ibm.com/pc/support</a>	IBM Personal Computing Support
<a href="http://www.ibm.com/pc/us/accessories">http://www.ibm.com/pc/us/accessories</a>	Options by IBM (U.S.)
<a href="http://www.ibm.com/pc/us/eserver/xseries">http://www.ibm.com/pc/us/eserver/xseries</a>	IBM xSeries Servers (U.S.)
<a href="http://www.ibm.com/pc/techconnect">http://www.ibm.com/pc/techconnect</a>	IBM TechConnect

You can select a country-specific Web site from these pages.

If you select Profile from the support page, you can create a customized support page that is specific to your hardware, complete with Frequently Asked Questions, Parts Information, Technical Hints and Tips, and Downloadable Files. You will have the information you need, all in one place. In addition, you can choose to receive e-mail notifications whenever new information becomes available about your registered products. You can also access online support forums, which are community sites that are monitored by IBM support staff.

---

## Appendix C. Product notices

This chapter contains trademarks and general-information notices.

---

### Notices

This publication was developed for products and services offered in the U.S.A.

IBM may not offer the products, services, or features discussed in this document in other countries. Consult your local IBM representative for information on the products and services currently available in your area. Any reference to an IBM product, program, or service is not intended to state or imply that only that IBM product, program, or service may be used. Any functionally equivalent product, program, or service that does not infringe any IBM intellectual property right may be used instead. However, it is the user's responsibility to evaluate and verify the operation of any non-IBM product, program, or service.

IBM may have patents or pending patent applications covering subject matter described in this document. The furnishing of this document does not give you any license to these patents. You can send license inquiries, in writing, to:

*IBM Director of Licensing  
IBM Corporation  
North Castle Drive  
Armonk, NY 10504-1785  
U.S.A.*

INTERNATIONAL BUSINESS MACHINES CORPORATION PROVIDES THIS PUBLICATION "AS IS" WITHOUT WARRANTY OF ANY KIND, EITHER EXPRESS OR IMPLIED, INCLUDING, BUT NOT LIMITED TO, THE IMPLIED WARRANTIES OF NON-INFRINGEMENT, MERCHANTABILITY OR FITNESS FOR A PARTICULAR PURPOSE. Some states do not allow disclaimer of express or implied warranties in certain transactions, therefore, this statement may not apply to you.

This information could include technical inaccuracies or typographical errors. Changes are periodically made to the information herein; these changes will be incorporated in new editions of the publication. IBM may make improvements and/or changes in the product(s) and/or the program(s) described in this publication at any time without notice.

Any references in this publication to non-IBM Web sites are provided for convenience only and do not in any manner serve as an endorsement of those Web sites. The materials at those Web sites are not part of the materials for this IBM product, and use of those Web sites is at your own risk.

IBM may use or distribute any of the information you supply in any way it believes appropriate without incurring any obligation to you.

### Edition notice

**© COPYRIGHT INTERNATIONAL BUSINESS MACHINES CORPORATION, 2001.  
All rights reserved.**

Note to U.S. Government Users — Documentation related to restricted rights — Use, duplication or disclosure is subject to restrictions set forth in GSA ADP Schedule Contract with IBM Corp.

## Processing date data

This IBM hardware product and IBM software products that might be packaged with it have been designed, when used in accordance with their associated documentation, to process date data correctly within and between the 20th and 21st centuries, provided all other products (for example, software, hardware, and firmware) used with these products properly exchange accurate date data with them.

IBM cannot take responsibility for the date data processing capabilities of non-IBM products, even if those products are preinstalled or otherwise distributed by IBM. You should contact the vendors responsible for those products directly to determine the capabilities of their products and update them if needed. This IBM hardware product cannot prevent errors that might occur if software, upgrades, or peripheral devices you use or exchange data with do not process date data correctly.

The foregoing is a Year 2000 Readiness Disclosure.

## Trademarks

The following terms are trademarks of the IBM Corporation in the United States, other countries, or both:

the e-business logo

HelpCenter

IBM

TechConnect

xSeries

Other company, product, and service names may be trademarks or service marks of others.

## Important notes

When referring to hard disk drive capacity, MB stands for 1 000 000 bytes and GB stands for 1 000 000 000 bytes. Total user-accessible capacity may vary depending on operating environments.

Maximum internal hard disk drive capacities assume the replacement of any standard hard disk drives and population of all hard disk drive bays with the largest currently supported drives available from IBM.

Unless otherwise stated, IBM makes no representations or warranties with respect to non-IBM products. Support (if any) for the non-IBM products is provided by the third party, not IBM.

Some software may differ from its retail version (if available), and may not include user manuals or all program functionality.







Part Number: 06P4866



Printed in the United States of America  
on recycled paper containing 10%  
recovered post-consumer fiber.

06P4866

