



# **IBM ThinkPad Multi-Burner Plus Ultrabay 加強型光碟機**

## **使用手冊**





# **IBM ThinkPad Multi-Burner Plus Ultrabay 加強型光碟機**

## **使用手冊**

註: 使用本資訊及其支援產品之前, 請先閱讀在第 B-1 頁的附錄 B, 『Service and Support』和  
第 C-1 頁的附錄 C, 『IBM Statement of Limited Warranty Z125-4753-08 04/2004』中的資訊。

# 目錄

安全資訊 . . . . .	v	使用 DVD 功能 . . . . .	2-5
一般安全準則 . . . . .	vii	啓用磁碟機機代號存取 (DLA) . . . . .	2-5
維修 . . . . .	vii	啓用 DMA 設定 . . . . .	2-6
電源線和電源整流器 . . . . .	vii	使用 Intervideo WinDVD Creator Plus . . . . .	2-7
延長線及相關裝置 . . . . .	vii	安裝 WinDVD 及觀賞 DVD 影片 . . . . .	2-7
插頭及插座 . . . . .	viii	啓動 WinDVD . . . . .	2-8
電池 . . . . .	viii	使用 CD-R 與 CD-RW 功能 . . . . .	2-8
熱能及產品通風 . . . . .	viii	使用 DVD-R/DVD-RW 與 DVD+R/DVD+RW 功能 . . . . .	2-9
CD 和 DVD 光碟機安全 . . . . .	ix	備製光碟或 DVD . . . . .	2-9
問題解決 . . . . .		問題解決 . . . . .	2-9
註冊您的選用設備 . . . . .	xi	附錄 A. 產品規格 . . . . .	A-1
第 1 章 關於 Multi-Burner Plus 光碟機 1-1		附錄 B. Service and Support . . . . .	B-1
產品說明 . . . . .	1-1	Online technical support . . . . .	B-1
軟體說明 . . . . .	1-2	Telephone technical support . . . . .	B-1
安裝需求 . . . . .	1-4	附錄 C. IBM Statement of Limited	
安裝光碟機 . . . . .	1-4	Warranty Z125-4753-08 04/2004 . . . . .	C-1
尋找光碟機控制元件 . . . . .	1-4	Part 1 - General Terms . . . . .	C-1
第 2 章 使用 Multi-Burner Plus 光碟機 2-1		Part 2 - Country-unique Terms . . . . .	C-4
準備工作 . . . . .	2-1	Part 3 - Warranty Information . . . . .	C-15
光碟的握拿與維護 . . . . .	2-1	Types of Warranty Service . . . . .	C-15
Multi-Burner Plus 光碟機的維護 . . . . .	2-2	附錄 D. Guarantee supplement for	
載入光碟 . . . . .	2-3	Mexico . . . . .	D-1
使用光碟機 . . . . .	2-3	附錄 E. Notices . . . . .	E-1
使用單面與雙面 DVD-RAM 媒體 . . . . .	2-3	Trademarks . . . . .	E-2
從卡匣中取出光碟 . . . . .	2-3	Electronic emission notices . . . . .	E-2
將光碟放回卡匣中 . . . . .	2-4	Federal Communications Commission (FCC) statement . . . . .	E-2
握拿時的注意事項 . . . . .	2-4		
搭配光碟與 DVD 使用光碟機 . . . . .	2-4		
手動退出光碟 . . . . .	2-4		
使用 DVD 播放程式軟體 . . . . .	2-5		



---

## 安全資訊

安裝本產品之前，請先閱讀「安全資訊」。

مج، يجب قراءة دات السلامة

Antes de instalar este produto, leia as Informações de Segurança.

在安裝本產品之前，請仔細閱讀 **Safety Information**  
(安全信息)。

Prije instalacije ovog produkta obavezno pročitajte Sigurnosne Upute.

Před instalací tohoto produktu si přečtěte příručku bezpečnostních instrukcí.

Læs sikkerhedsforskrifterne, før du installerer dette produkt.

Ennen kuin asennat tämän tuotteen, lue turvaohjeet kohdasta Safety Information.

Avant d'installer ce produit, lisez les consignes de sécurité.

Vor der Installation dieses Produkts die Sicherheitshinweise lesen.

Πριν εγκαταστήσετε το προϊόν αυτό, διαβάστε τις πληροφορίες ασφάλειας  
(safety information).

לפני שתתקינו מוצר זה, קראו את הוראות הבטיחות.

A termék telepítése előtt olvassa el a Biztonsági előírásokat!

Prima di installare questo prodotto, leggere le Informazioni sulla Sicurezza.

製品の設置の前に、安全情報をお読みください。

본 제품을 설치하기 전에 안전 정보를 읽으십시오.

Пред да се инсталира овој продукт, прочитајте информацијата за безбедност.

Lees voordat u dit product installeert eerst de veiligheidsvoorschriften.

Les sikkerhetsinformasjonen (Safety Information) før du installerer dette produktet.

Przed zainstalowaniem tego produktu, należy zapoznać się  
z książką "Informacje dotyczące bezpieczeństwa" (Safety Information).

Antes de instalar este produto, leia as Informações sobre Segurança.

Перед установкой продукта прочтите инструкции по  
технике безопасности.

Pred inštaláciou tohto produktu si prečítajte bezpečnostné informácie.

Pred namestitvijo tega proizvoda preberite Varnostne informacije.

Antes de instalar este producto lea la información de seguridad.

Läs säkerhetsinformationen innan du installerar den här produkten.

安裝本產品之前，請先閱讀「安全資訊」。



---

## 一般安全準則

請務必遵守下列預防措施以減少受傷及財產損壞的風險。

---

### 維修

請勿嘗試自己維修產品，除非 IBM 支援中心指示您這麼做。只將產品送至經核准修理您特定產品的 IBM 授權服務供應商。

**註：**客戶可以自行升級或更換部份零件。這些零件稱為客戶可更換裝置或 CRU。IBM 會明確指出這些 CRU，並在客戶更換這些零件時提供說明文件。您在執行這樣的更換時必須嚴格依照所有指示。在嘗試更換前，請務必確定電源已關閉，而且產品也切斷任何電源。如果您有任何問題或考量，請與 IBM 支援中心聯絡。

---

### 電源線和電源整流器

只使用產品製造廠商提供的電源線和電源整流器。

請勿將電源線繞在電源整流器或其他物品上。這麼做會導致電線磨損、斷裂或捲曲。這會帶來安全上的顧慮。

請勿將電源線佈置在容易被踩到、將人絆倒或被物品擠壓的地方。

避免電線及電源整流器碰觸到液體。例如，請勿將電源線或電源整流器留在靠近水槽、浴缸、廁所的地方或使用液體清潔劑清潔過的地板上。液體會引起短路，尤其是在不當使用而壓壞了電線或電源整流器的情況下。液體還會使電源線終端及/或整流器上的接頭終端逐漸腐蝕，最終導致過熱。

請務必按照正確的順序連接電源線及訊號線，並確保所有電源線接頭都安全並完全插入插座。

請勿使用交流電輸入接腳腐蝕及/或交流電輸入處或電源整流器上的任何地方有過熱跡象（如塑料變形）的任何電源整流器。

請勿使用任一端電氣接點有腐蝕或過熱跡象或電源線顯然已損壞的任何電源線。

---

### 延長線及相關裝置

經評估後，確定延長線、穩壓保護器、不斷電系統、以及所使用的多孔延長線可滿足本產品的耗電需求。使用上述裝置時，勿使耗電量超載。如果使用多孔延長線，負載不應超過多孔延長線輸入額定功率。有關電源負載、電源需求及輸入額定功率的問題，請向電氣技術人員請教以獲得更多資訊。

---

## 插頭及插座

如果與電腦設備搭配使用的插座（電源插座）看起來損壞或腐蝕，請讓合格的電氣技術人員更換插座後再使用。

請勿彎曲或變更插頭。如果插頭損壞，請與製造廠商聯絡以取得更換品。

部份產品配有三相插頭。這類插頭只適合接地電源插座。這是安全特殊裝置。請勿嘗試將其插入非接地的插座中，會破壞此項安全特性。如果您無法將插頭插入插座，請與電氣技術人員聯絡，取得經認證的插座整流器，或將插座更換為可使用這類安全特殊裝置的插座。請勿使輸電插座超載。系統的總負載不能超過旁路比率的百分之八十。有關電源負載及旁路額定功率的問題，請向電氣技術人員請教以獲得更多資訊。

請確定您使用的電源插座適當接線、可方便存取且位置接近設備。請勿將電源線拉到處於受力的狀態。

小心地將設備從電源插座上插拔。

---

## 電池

所有 IBM 個人電腦都附有不可充電的硬幣狀電池，來為系統時鐘提供電源。此外，許多攜帶式產品（如 Thinkpad 筆記型電腦）在攜帶時是利用充電電池組提供系統電源。IBM 提供來與您的產品搭配使用的電池已經過相容性測試，僅應以 IBM 核准的零件更換。

切勿嘗試打開或維修任何電池。請勿壓碎、戳破或焚燒電池或使金屬接點短路。請勿讓電池接觸到水或其他液體。請務必嚴格遵照產品文件中所附的說明來對電池組充電。

電池過度使用或處理不當會導致電池過熱，可能造成電池組或硬幣電池「放出」氣體或火焰。如果您的電池已經受損，或您注意到電池有任何的漏溢情況，或電池極端出現雜質堆積，請停止使用電池，並向電池製造廠商購買新電池。

電池很久沒用時會降解。對於一些充電電池來說（尤其是鋰電池），電池在放電狀態下不使用會增加電池短路的危險，縮短電池的壽命，也具有安全上的顧慮。請勿讓充電鋰電池完全放電，或讓這些電池處於放電狀態。

---

## 熱能及產品通風

電腦在開啓和電池充電時會產生熱能。筆記型電腦由於體積較小，因此會產生相當多的熱能。請務必依照以下的基本預防措施：

- 當電腦正在運作或電池充電時，請勿長時間將電腦底座放在膝上或身體的任一部份。您的電腦在一般操作期間會產生一些熱能。長時間與身體接觸可能會引起不舒服或可能造成皮膚灼傷。
- 請勿在易燃物附近或易爆炸的環境下操作電腦或為電池充電。
- 為求安全、舒適和可靠操作，產品附有通風槽、風扇及/或散熱器。這些特殊裝置可能會由於產品放置在床、沙發、地毯或其他彈性表面上而無法發揮功能。切勿阻礙、遮蓋或停用這些特殊裝置。

---

## CD 和 DVD 光碟機安全

CD 和 DVD 光碟機以高速旋轉光碟。如果 CD 或 DVD 有破裂或任何受損，使用 CD 光碟機時，光碟有可能會斷開甚至會破碎。爲了防止這種情況可能導致的損傷並減少機器損壞的危險，請執行下列步驟：

- 務必將 CD/DVD 光碟存放在原始包裝中
- 務必將 CD/DVD 光碟存放在遠離陽光直射及直接熱源處
- 不用時，請從電腦中取出 CD/DVD 光碟
- 勿彎曲或屈折 CD/DVD 光碟，或將它們強行放入電腦或其包裝中
- 在使用每片 CD/DVD 光碟前請檢查是否有破裂。請勿使用破裂或損壞的光碟



---

## 註冊您的選用設備

感謝您購買本 IBM® 產品。請用一點時間為產品註冊，並提供一些相關資訊，這將幫助 IBM 在未來提供您更好的服務。您的回應在開發對您相當重要的產品和服務時會很有價值，並且能提供最佳的溝通管道。您可以在下列的 IBM 網站上註冊您的選用設備：

<http://www.ibm.com/pc/register/>

除非您在網站上的問卷指出，您不想收到進一步的資訊，否則 IBM 會提供您所註冊的產品的資訊及更新。



---

## 第 1 章 關於 Multi-Burner Plus 光碟機

本手冊提供有關 IBM® ThinkPad® Multi-Burner Plus Ultrabay™ 加強型光碟機的註冊、安裝及使用資訊；您可從 *Software and User's Guide Super CD* 中取得以下各語言版本：

- 巴西葡萄牙文
- 捷克文
- 英文
- 法文
- 德文
- 義大利文
- 日文
- 簡體中文
- 斯洛伐克文
- 西班牙文
- 繁體中文
- 土耳其文

本手冊的附錄中有保證資訊與法律注意事項。

---

### 產品說明

本 Multi-Burner Plus 與 DVD Forum DVD-Multi Recorder 規格相容，並可錄製及讀取 DVD-RAM、DVD-RW 及 DVD-R（一般為 650 nm）媒體。本光碟機也可錄製 DVD+R、DVD+RW、CD-R、CD-RW 及高速 CD-RW 媒體。本光碟機採用執行中緩衝區防護技術來確定 DVD-R、DVD+R 及 CD-R 媒體燒錄作業的可靠性。Multi-Burner Plus 還可讀取其他多種格式，包括 DVD 視訊、影音光碟、音效光碟、多重區段、延伸架構 (XA) 光碟，及柯達照片光碟。Multi-Burner Plus 設計安裝在 Ultrabay 加強型磁碟機機槽中。

媒體類型	寫入速度
CD-R	最快速度：24X
CD-RW	4X
高速度 CD-RW	10X
超高速 CD-RW	16X
DVD-R	最快速度：8X
DVD+R	最快速度：8X
DVD-RW	最快速度：4X
DVD+RW	最快速度：4X
DVD-RAM	最快速度：3X

除了本手冊以外，您的選用設備包裝內還有以下各項：

- Multi-Burner Plus 光碟機
- Ultrabay 2000 的加強型光碟機介面卡
- 背包

- *Software and User's Guide Super CD*
- 快速參考手冊

如果有任何物品遺漏或損壞，請與原經銷商聯絡。請務必保留您的購買證明，因為可能必須出示購買證明，才能享有保證服務。請參閱第 C-1 頁的附錄 C, 『IBM Statement of Limited Warranty Z125-4753-08 04/2004』，取得技術支援資訊。

## 軟體說明

您的 IBM Multi-Burner Plus *Software and User's Guide Super CD* 包含下列軟體及需求：

- **Intervideo WinDVD Creator Plus**

您可以使用本軟體將視訊檔錄製到 DVD-RW、DVD+RW、DVD-R 或 DVD+R 媒體，並在大部份的獨立式 DVD 播放器中播放。您也可先用本軟體來編輯及修改您自己的視訊資產，再進行錄製作業。

如果您的電腦中有安裝類比或 IEEE 1394 擷取裝置，您可利用本軟體來錄製攝影機中的視訊。

下表提供了有關 Intervideo WinDVD Creator Plus 系統需求的資訊。

電腦零件	最小值	最佳值
處理器	Intel Celeron 800Mhz	Intel Pentium III 600Mhz  必須配有可提供即時需求的 P4 1.6GHz 或以上，才能直接支援 DVD
RAM	64Mb	128Mb
作業系統	Windows 2000 或 Windows XP	Windows 2000 或 Windows XP
音效	可支援 48KHz 播放的 Windows 相容音效卡	可支援 48KHz 播放（建議採用 PCI）的 Windows 相容音效卡
視訊	Windows 相容 AGP 或 PCI 圖形卡	Windows 相容 AGP 或 PCI 圖形卡（建議採用重疊支援）
硬碟	<ul style="list-style-type: none"> <li>• 70 MB 供安裝使用</li> <li>• 一小時 VCD 品質 MPEG-1 視訊需要 620 MB</li> <li>• 一小時 DVD 品質 MPEG-2 視訊需要 2 GB</li> </ul>	<ul style="list-style-type: none"> <li>• 70 MB 供安裝使用</li> <li>• 一小時 VCD 品質 MPEG-1 視訊需要 620 MB</li> <li>• 一小時 DVD 品質 MPEG-2 視訊需要 2 GB</li> </ul>
其他		可用來燒錄 VCD 與 DVD 的光碟或 DVD 燒錄器。可用來從外部來源匯入視訊的適當硬體，如 DV 攝影機與手提式錄影機。

註：WinDVD Creator Plus 可利用預先安裝的 DivX 編碼解碼器來匯入及匯出 DivX 內容。DivX 是 DivXNetworks, Inc. 的商標。

- **IBM 磁碟機代號存取 (DLA)**



透過本軟體，您可以利用磁碟機代號來直接寫入 CD-RW、CD-R、DVD-RAM、DVD-RW、DVD+RW、DVD-R 及 DVD+R 媒體，就好像您寫入磁片一樣。DLA 可以格式化所有光碟格式類型。使用 DLA 可讓您拖放、建立新目錄，或從任何應用程式中將檔案直接儲存到您的 Multi-Burner Plus。

#### • UDF Reader

在配有 DVD 光碟機的電腦上，您可利用本軟體來安裝可讀取 DVD-RAM、DVD-RW、DVD+RW 及 CD-RW 媒體的軟體。另外，它還可讓您在沒有安裝 DLA 的系統上讀取 DLA 所建立的光碟。

#### • IBM RecordNow

IBM RecordNow 是一種光碟控制軟體，本軟體可讓您從您電腦上的檔案或從其他光碟媒體（例如 CD 或 DVD）建立您自己的音樂光碟或資料光碟。用 IBM RecordNow 建立的音樂光碟可在任何光碟播放器上播放，不論是家用光碟播放器、車用光碟播放器或電腦用 CD 光碟機，都可播放。IBM RecordNow 可以很容易地建立資料光碟，並可讓您在任何適用的光碟或 DVD 光碟讀取器上讀取這些資料光碟。

**註：**某些 DVD 播放器無法讀取 CD-R 媒體。請參閱本光碟機檢附文件，取得支援媒體相關資訊。

IBM RecordNow 會利用簡單的精靈與直覺式介面逐步引導您執行錄製程序。

您可利用 IBM RecordNow 建立以下各項：

- 現有光碟的完全拷貝：這項「完全拷貝」功能可製作和主要光碟一模一樣的複本，將原光碟的配置轉送到 CD-R、CD-RW 或 DVD 媒體。
- 硬碟保存資料光碟：這項「資料光碟」功能可以儲存電子資料，如電腦硬碟中的檔案與應用程式。跟音樂光碟不同，資料光碟儲存只能用電腦讀取、不能用家用或車用立體音響來播放的檔案，即使光碟中有音訊檔也一樣不能播放。
- 從 WAV、MP3、WMA 檔或現有音樂光碟中編譯而成的音樂：本「製作音樂光碟」功能可讓您從硬碟或現有音樂光碟的檔案建立自訂音樂光碟。「光碟音樂資料庫」特性可自動利用磁軌資訊來標示檔案，協助您對所收集的音樂進行排序。

**註：**請參閱 IBM RecordNow 線上說明，取得有關如何利用 IBM RecordNow 來「製作完全拷貝」、「建立資料光碟」或「建立音訊光碟」的其他資訊。

如果要啟動 RecordNow，請完成下列程序：

1. 按一下**開始**。
2. 按一下**程式集**。
3. 按一下 **IBM RecordNow**。
4. 按一下 **RecordNow**，來開啓錄製軟體的主視窗。

#### • IBM 簡式備份

本軟體可讓您在 DVD-RAM、DVD-RW、DVD-R、CD-R、CD-RW、DVD+R 或 DVD+RW 媒體上建立系統檔的完整備份或遞增式備份，並可讓您在電腦失靈時利用這些備份來還原電腦。

#### • Intervideo WinDVD

本軟體可讓您播放電腦上的 DVD 視訊，或播放硬碟機中的視訊檔。

註：某些圖形配接卡（如 FIREGL、Intergraph 及 3dLabs）不支援 DVD 視訊播放。

---

## 安裝需求

安裝 Multi-Burner Plus 光碟機時，您的 ThinkPad 電腦必須符合下列需求：

- 具有 Ultrabay 加強型磁碟機機槽、或 ThinkPad Dock 或 Dock II 的 ThinkPad 系統
- Ultrabay 2000 的加強型光碟機介面卡
- Microsoft® Windows® XP 或 Microsoft Windows 2000 Professional 作業系統

註：

1. IBM 對於備有 Microsoft Windows 95、Microsoft Windows 98 或 Microsoft Windows Millennium Edition (Me) 桌面作業系統的電腦只能提供限制性支援。
2. ThinkPad A21e 電腦在 Windows NT 下不支援 DVD 播放。

---

## 安裝光碟機

您的 ThinkPad 電腦內含說明系統 (Access ThinkPad)，此系統可提供您電腦專屬的光碟機安裝指示。如果要將 Multi-Burner 光碟機正確安裝在 Ultrabay 加強型磁碟機機槽中，請使用 Access ThinkPad 說明系統所提供的指示。

---

## 尋找光碟機控制元件

下列圖解顯示光碟機前部各控制元件的位置：

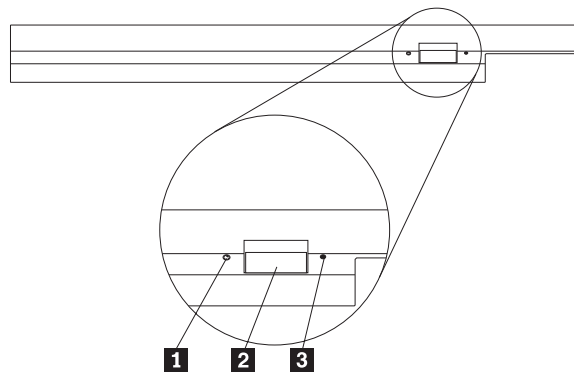

**1** 電源指示燈：當光碟機正在使用中時，此指示燈會亮起。

**2** 退出按鈕：按下此按鈕後，可將 DVD 或 CD 退出。

**3** 手動退出小孔：退出鈕無法運作時，您可使用此緊急釋放裝置將 DVD 或 CD 退出。如需有關手動退出 DVD 或 CD 的其他資訊，請參閱第 2-4 頁的『手動退出光碟』。

---

## 第 2 章 使用 Multi-Burner Plus 光碟機

本節提供有關如何握拿、載入和維護 DVD 與 CD，以及如何維護本 Multi-Burner Plus 光碟機的資訊。

---

### 準備工作

為求最佳效果，請先檢視下列準則，再使用本光碟機：

- 正在格式化或寫入光碟時，請不要移動 ThinkPad 電腦，因為這樣可能會造成資料錯誤。此外，正在格式化或寫入光碟時，請盡量不要打字，因為這樣也可能會造成資料錯誤。
- 要寫入光碟時，請將 ThinkPad 電腦擺放在平坦表面上。
- 要使用本光碟機時，請務必將 ThinkPad 電腦插入交流電插座中。如果正在寫入光碟時電池沒電，可能會損壞光碟。
- 請關閉螢幕保護程式。使用螢幕保護程式可能會中斷格式化與寫入程序。
- 正在寫入光碟時，請不要讓 ThinkPad 電腦進入休眠或暫停模式。

**註：**本光碟機的讀/寫效果取決於所用 DVD 或 CD 媒體的品質與性質。

---

### 光碟的握拿與維護

請小心握拿和清潔光碟，特別是 CD-R 和 CD-RW 光碟之類的可寫入媒體類型，這樣才能保持可讀性。您可以利用下列預防措施，來延長光碟的壽命。

- 務必將光碟存放在原包裝中。
- 請勿將光碟存放在有直接日照的地方。
- 請勿將光碟存放在靠近有直接熱源的地方。
- 不使用電腦時，請將光碟從電腦中取出。
- 每一次使用前請檢查光碟是否破損。

**重要事項：**請勿使用破損的光碟。

- 不要將光碟硬塞至電腦或包裝中。
- 請勿將光碟彎曲或屈伸。
- 請勿使用商用吸塵器清理光碟。
- 請勿在光碟表面書寫。

- 請握拿光碟的邊緣或中央小孔。
- 請勿觸摸光碟的表面。
- 如果要清除灰塵或指印，請用一塊不含棉絮的軟布，從中央往邊緣的方向擦拭光碟。

**請注意：**以環形動作擦拭光碟可能會造成資料流失。

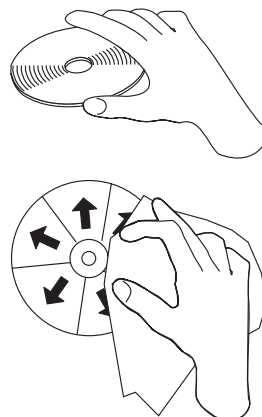

---

## Multi-Burner Plus 光碟機的維護

操作時，請遵守下列預防措施，以保護本光碟機：

- 移動光碟機之前，請先從光碟機中取出光碟。
- 請勿將異物插入光碟機中。
- 請勿在光碟機上堆置物體。
- 請勿拆除光碟機外殼或試圖維修光碟機。
- 請勿在以下任何狀況操作光碟機：
  - 高溫、高濕度或直接日照
  - 過度震動、突然震動或傾斜的表面
  - 過多灰塵

## 載入光碟



1. 按下退出鈕。這時托盤會從光碟機中滑出。
2. 將光碟放在托盤中，標籤朝上。
3. 輕輕推一下托盤來關閉托盤，使它完全關上。

**請注意：**請勿用力或利用異物打開托盤。如果按下退出鈕時無法打開托盤，請參閱第 2-4 頁的『手動退出光碟』，取得其他資訊。

## 使用光碟機

本節列有使用 Multi-Burner 的相關資訊。

### 使用單面與雙面 DVD-RAM 媒體

DVD-RAM 媒體分為單面與雙面兩種。

2.6 GB 與 4.7 GB 這兩種都是單面。9.4 GB 這一種是雙面。如果要在媒體的雙面存取資料，您必須從光碟機中取出媒體，將它翻面，然後重新插入光碟機中。

### 從卡匣中取出光碟

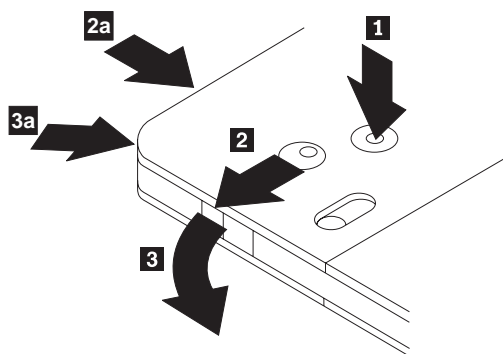

DVD-RAM 媒體分為無遮蔽式光碟與卡匣兩種。如果要在 Multi-Burner 中使用卡匣媒體，您必須先從卡匣中取出光碟。

1. 用原子筆筆尖推壓並分開鎖定接腳卡栓 **1**。

2. 如果要取出光碟，請用原子筆將卡匣蓋鎖定裝置 **2** 往下推，然後將卡匣蓋拉出 **3**。

打開卡匣蓋後，便可取出光碟。

**註：**卡匣蓋鎖定裝置與卡匣蓋卡栓位於某些卡匣的側邊，如上圖 **2a** 與 **3a** 所示。

**警告：** 握拿無遮蔽式媒體時，請勿觸摸光碟的錄製區。

## 將光碟放回卡匣中

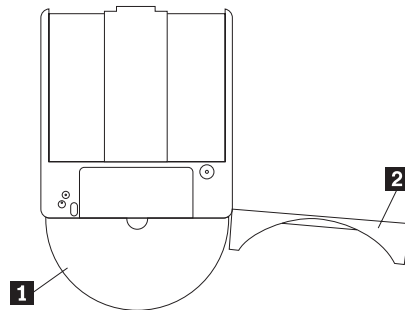

1. 如果要將光碟放回卡匣中，請將光碟的標籤面 **1** 對齊 DVD-RAM 卡匣的標籤面。
2. 插入光碟，並關上卡匣蓋 **2**。卡匣蓋關上時，會發出喀嚓聲。

## 握拿時的注意事項

握拿取出的光碟時要小心。殘餘物、塵粒、指印、污漬或刮痕都可能導致媒體的錄製與播放效果受損。如果要清理灰塵或其他殘餘物，請使用光碟清潔套件。請用柔軟的乾布清理光碟。請勿使用溶劑清理光碟表面。要標示光碟時，只能使用軟性氈頭筆具在列印標籤面或卡匣上書寫。請避免直接日照、高溫及高濕度等狀況。請勿在光碟的任一面上黏貼標籤。

---

## 搭配光碟與 DVD 使用光碟機

請完成下列程序來讀取資料光碟：

1. 開啓電腦的電源。
2. 按下光碟機前部的「開啓/關閉」按鈕。
3. 將光碟或卡匣插入托盤，標籤朝上。
4. 按下「開啓/關閉」按鈕或輕輕推一下載入用托盤，將托盤關上。

**警告：** 請勿用力或利用異物打開載入用托盤。

5. 等光碟機忙碌指示燈熄滅後，再連按兩下**我的電腦**。
6. 連按兩下 **CD-ROM** 或 **DVD-RAM/DVD-R/DVD-RW** 圖示。

## 手動退出光碟

如果您按下退出鈕後托盤沒有滑出，請先關閉電腦的電源，然後將一支大迴紋針拉直做成一個工具，如圖所示。拉直的一端長度至少要 45 公釐（1.8 英吋）。將拉直的那一端插入光碟機前部的手動退出小孔中。請推入迴紋針，直到托盤打開為止；將托盤

輕輕往外推，直到您能移除光碟為止。

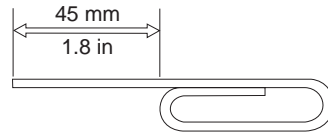

---

## 使用 DVD 播放程式軟體

本節說明如何使用及自訂 DVD 播放程式軟體。您可在 *User's Guide and Software Super CD* 的 README 檔中找到有關 DVD 播放程式軟體的最新資訊。

---

## 使用 DVD 功能

如果要使用 DVD 功能，您必須在本 Multi-Burner Plus 光碟機安裝於 Ultrabay 加強型磁碟機機槽後，將電腦設定如下：

1. 啟用 DMA 設定（僅適用於 Windows XP 與 Windows 2000 使用者）。
2. 安裝 WinDVD（DVD 影片播放程式）。

**註：**在 Windows 95 中，本 DVD 影片播放程式可獲得 Windows 95 OSR2.0 或更新的版本的支援。您可遵循下列步驟來檢查您所用 Windows 95 版本：

1. 按一下**開始**，將游標移到**設定**，然後按一下**控制台**。
2. 連按兩下**系統**。

閱讀「系統」下方的號碼。

- 4.00.950B 表示您所用的版本是 Windows 95 OSR2.0 或 OSR2.1。
- 4.00.950C 表示您所用的版本是 Windows 95 OSR2.5。

## 啓用磁碟機代號存取 (DLA)

磁碟機代號存取 (DLA) 這項功能可讓您將資料寫入 CD-R、CD-RW、DVD-RAM、DVD-RW 及 DVD-R 媒體。

DVD-RAM、DVD-RW、DVD+RW、CD-RW、DVD-R、DVD+R 及 CD-R 媒體可多次寫入資料（可在 DVD-R 與 CD-R 媒體上附加資料，直到這些光碟已滿為止）。

要格式化及寫入 DVD-R、DVD+R、CD-R、DVD-RAM、DVD-RW、DVD+RW 或 CD-RW 媒體：

1. 將光碟插入光碟機。
2. 連按兩下**我的電腦**。用滑鼠右鍵按一下 Multi-Burner 磁碟機代號。
3. 按一下**格式化**。格式化時間的長短視您所用的格式化程序（「快速」或「完整」）而定。
4. 完成格式化程序後，您可將檔案拖放到 Multi-Burner 光碟機圖示，或將檔案移到 Windows Explorer 中。

如何讓 CD-R 媒體與其他電腦相容：

1. 連按兩下**我的電腦**。用滑鼠右鍵按一下 Multi-Burner 磁碟機代號。
2. 按一下**建立相容性**。

爲了在其他電腦中使用以 UDF 格式化的 DVD-RAM、DVD-RW、DVD+RW 或 CD-RW 媒體，*User's Guide and Software Super CD* 併入了 UDF Reader。要使用該 UDF Reader，請遵循下列程序：

1. 在您要使用以 UDF 格式化的光碟的那部電腦，將 *User's Guide and Software Super CD* 插入到 CD 或 DVD 光碟機中。
2. 按一下**開始**。
3. 按一下**執行**。
4. 輸入 `e:\UDF\language` 其中 *e* 是 CD 或 DVD 光碟機的磁碟機代號，*language* 則是您所用的語言。
5. 按一下**確定**。
6. 連按兩下 **SETUP.EXE**，然後遵循螢幕指示。

**註：**未安裝其他 DLA 程式供 CD-RW、DVD+RW 或 DVD-RW 使用的系統才需要 UDF Reader。

## 啓用 DMA 設定

本節說明如何在 2000 與 Windows XP 中啓用 DMA 設定。

### Windows 2000：

1. 按一下**開始**，將游標移到**設定**，然後按一下**控制台**。
2. 連按兩下**系統**。
3. 按一下**硬體**標籤。
4. 按一下**裝置管理員**按鈕。
5. 按一下 **IDE ATA/ATAPI 控制器**來拉下子功能表。
6. 連按兩下**次要 IDE**。（如果您使用的是 ThinkPad A21e 電腦，請連按兩下**主要 IDE**。）
7. 選取**可使用 DMA** 當作傳送模式。
8. 按一下**確定**。
9. 按一下**關閉**來關閉「系統內容」視窗。這時便會顯示一則訊息，通知您系統設定已經變更。
10. 按一下**確定**來重新啓動系統。

### Windows XP：

1. 按一下**開始**，將游標移到**我的電腦**，然後按一下。
2. 在「系統作業」下方，按一下**檢視系統資訊**。
3. 按一下**硬體**標籤。
4. 按一下**裝置管理員**按鈕。
5. 按一下 **IDE ATA/ATAPI 控制器**來拉下子功能表。
6. 連按兩下**次要 IDE**。（如果您使用的是 ThinkPad A21e 電腦，請連按兩下**主要 IDE**。）
7. 按一下**進階設定**標籤。
8. 選取**可使用 DMA** 當作傳送模式。
9. 按一下**確定**。



10. 按一下**關閉**來關閉「系統內容」視窗。

## 使用 Intervideo WinDVD Creator Plus

您可利用 Intervideo WinDVD Creator Plus 來擷取、編輯及錄製視訊檔與音訊檔。在 Intervideo WinDVD Creator Plus 中，您還可使用您自己的視訊檔與音訊檔來建立及錄製 DVD 視訊。Intervideo WinDVD Creator Plus 與 DVD-R、DVD+R、DVD-RW、DVD+RW 及 DVD-RAM 媒體搭配使用。如需有關 Intervideo WinDVD Creator Plus 功能的其他詳細資訊，請至 *User's Guide and Software Super CD* 上的「WinDVD Creator Plus 使用手冊」。

WinDVD Creator Plus 主視窗內的主要功能區域有「擷取」、「編輯」、「作者」和「製作影片」。您可利用這些功能來匯入及編輯您自己的視訊檔與音訊檔，然後將這些檔案儲存為支援格式。支援格式包括 MPEG-1、MPEG-2、ASF、WMV 和 AVI。當您執行「擷取」及「編輯」步驟，將您的視訊檔與音訊檔準備好之後，便可從「作者」功能內新增自訂功能表。您可匯入您自己的靜態影像當做功能表背景，或選取其中一個範例影像。備妥您的影片之後，請繼續執行「製作影片」，您可在該功能區中選取您的影片製作中所使用的輸出格式與視訊標準。請將您的影片燒錄到光碟，或將它儲存在硬碟中，以後再燒錄。如果您使用 WinDVD Creator Plus 將 DVD 影像檔建立在硬碟中，請從「專案」功能表中選取「載入要燒錄的影像檔」。

WinDVD Creator Plus 還提供另外一項功能，可以讓您使用「磁碟管理程式」將視訊直接錄製到 DVD 可錄製媒體上，執行這項作業並不會佔用任何額外的硬碟空間。您可利用「磁碟管理程式」來擷取新視訊或使用您現有的視訊檔，然後建立自訂功能表來完成您的影片。您可採用 +VR 或 -VR 視訊格式來建立您的影片。有了「磁碟管理程式」，您隨時都可以編輯您的影片、新增/刪除視訊區段，或變更自訂功能表。

## 安裝 WinDVD 及觀賞 DVD 影片

如果要安裝 WinDVD，請至 *Software and User's Guide Super CD* 中的「軟體」一節。

安裝 Multi-Burner 光碟機與 WinDVD 軟體之後，便可觀賞 DVD 影片。不過，您必須先設定 DVD 內容的 DVD 區域碼。

### DVD 區域碼

DVD 區域碼有助於保護 DVD 的內容。全世界分為六個區域，特定的內容只可在適當的地區才能夠播放。例如，區域碼 1 的內容只可在美國與加拿大播放。WinDVD 同樣也依區域而定。

您可以在內容包裝背面的地區符號，查看光碟內容的區域碼。

區域碼	地區
1	美國、加拿大
2	歐洲、中東、南非、日本
3	東南亞、台灣、韓國
4	拉丁美洲、澳洲、紐西蘭
5	前蘇聯、北非、印度
6	中華人民共和國

將 DVD 插入光碟機以啓動 WinDVD。系統會自動設定區域碼，以便讓您觀賞影片。這是起始設定。

設定好區域碼後，如果您插入其他區域碼的 DVD，系統會出現提示，要求您變更區域碼。您可以變更起始區域碼，最多四次。

區域碼的起始設定最多可變更四次，之後便不可以變更。之後，您只能播放該地區適用的 DVD 內容。

如果要顯示區域碼狀態，請按一下 WinDVD 使用者介面上的 **WinDVD 內容** 按鈕。**一般事項** 標籤中有這項資訊。

如果要變更區域碼，請執行下列步驟：

1. 開啓電腦的電源，並啓動作業系統。
2. 按一下 **開始**。
3. 選取 **程式集**。
4. 按一下 **Intervideo WinDVD**。
5. 按一下 **內容** 圖示，開啓 **內容** 視窗。
6. 按一下 **一般內容** 索引標籤。
7. 插入屬於新區域的單一區域 DVD。
8. 針對您的國家選取正確的區域碼。
9. 按一下 **確定**。

## 啓動 WinDVD

若要啓動 WinDVD，請完成下列程序：

1. 按一下 **開始**。
2. 按一下 **程式集**。
3. 按一下 **InterVideo WinDVD**。
4. 按一下 **InterVideo WinDVD**，來開啓 DVD 影片播放程式視窗。

有關如何使用 DVD 影片播放程式的其他資訊，請參閱 *Software and User's Guide Super CD* 中的 WinDVD 說明資訊。如果您想使用電視觀賞 DVD 影片，請參閱您的電腦所提供的線上資訊。

### 註：

1. 本電腦已經配置妥在足夠的可用的系統資源下可提供高品質音訊以及視訊播放效果。您可在「控制台」變更視窗解析度的預設值。有些系統即使設定完整的解析設定，仍無足夠的資源可提供完整品質的音訊與視訊播放。如果您遇到播放效能不佳的問題，請將解析設定調低。
2. 音訊或視訊是由軟體解碼。音訊與視訊子系統必須啓用以及完整運作。

---

## 使用 CD-R 與 CD-RW 功能

本 Multi-Burner 光碟機可寫入 CD-R 與 CD-RW 光碟上。CD-R 光碟無法消除，但可與標準 CD 光碟機與光碟播放器搭配使用。

您可使用 CD-R 光碟錄製音軌、儲存資料、保存檔案及複製另一片光碟上的檔案。

CD-RW 光碟可消除及重新寫入，但只能跟與 MR- 及 CD-RW 相容的較新型 CD 光碟機與 DVD 光碟機搭配使用。您可使用 CD-RW 光碟來備製、儲存及更新檔案，或複製其他光碟中的檔案。

註：

1. CD-R 光碟可在音訊光碟播放器中播放。但大部分的音訊光碟播放器都無法播放 CD-RW 光碟。
2. 本光碟機所檢附的軟體無法讓您在 DOS、Windows 3.x 或 IBM OS/2® 作業系統上使用本光碟機的光碟錄製功能。

有關如何使用此軟體的其他資訊，請參閱 *Software and User's Guide Super CD* 中的 IBM RecordNow 與 IBM DLA 說明資訊。

---

## 使用 DVD-R/DVD-RW 與 DVD+R/DVD+RW 功能

本 Multi-Burner 光碟機可寫入 DVD-R、DVD-RW、DVD+R 及 DVD+RW 光碟。DVD-R 與 DVD+R 光碟無法抹寫，但可與標準 DVD 光碟機與 DVD 播放器搭配使用。

您可使用 DVD-R 與 DVD+R 光碟錄製音軌、儲存資料、保存檔案及複製另一片 DVD 上的檔案。

DVD-RW 與 DVD+RW 光碟可消除及重新寫入，但只能與相容於 MR- 及 DVD-RW 的較新型 CD 光碟機與 DVD 光碟機搭配使用。您可使用 DVD-RW 與 DVD+RW 光碟來備份、儲存及更新檔案，或複製其他 DVD 中的檔案。

有關如何使用此軟體的其他資訊，請參閱 *Software and User's Guide Super CD* 中的 IBM RecordNow 與 IBM DLA 說明資訊。

---

## 備製光碟或 DVD

您必須擁有著作權或獲得著作權所有人的許可，才能複製商用光碟或 DVD。如果您沒有著作權或沒有獲得著作權所有人的許可，您可能會違反著作權法，並需就損壞或其他補救方式擔負付款責任。有關著作權法的其他資訊，請諮詢您的法律顧問。

---

## 問題解決

電腦問題可能是由硬體、軟體或使用者錯誤所造成。本節中的資訊可能有助您解決問題，或有助於您收集有用的資訊，然後傳送給維修技術人員。另外，您可能也需要參閱您的電腦、作業系統或音效卡等相關使用說明。

在下列清單中，檢視所有可能符合所發生情形的問題說明。

**無法建立多重作業階段光碟。**

請確定該光碟留有足夠的空間供另一個階段作業使用。寫入階段作業時，除錄製資料所需的空間外，另需導入與導入空間（約 15 MB）。

**無法順利寫入 CD-R、CD-RW、DVD-R、DVD-RW、DVD+R、DVD+RW 或 DVD-RAM 光碟。**

請採取下列動作：

1. 驗證寫入程序未遭螢幕保護程式、防毒程式、網際網路/電子郵件程式或其他軟體中斷。請停用所有可能中斷寫入作業的功能。
2. 驗證硬碟已經重組。
3. 向硬碟機製造廠商或供應商詢問舊式硬碟機在執行寫入作業期間是否會執行熱量重新校準作業。
4. 如果光碟損壞或有刮痕，請更換光碟。
5. 停用 Windows「自動插入通知」功能，不要讓系統對您的 CD 光碟機與 CD-RW 光碟機執行這項功能。

#### **無法退出光碟或 DVD 光碟。**

請確認光碟機並非正在寫入光碟，然後執行下列動作：

1. 利用軟體退出光碟。
2. 使用退出鈕。
3. 關閉電腦的電源。等待 45 秒再開啓電腦的電源，然後重新嘗試使用退出鈕。
4. 如果其他方法都無效，請遵循第 2-4 頁的『手動退出光碟』所提供的指示來使用手動退出小孔。

#### **順利寫入光碟後無法讀取 CD 或 DVD 光碟。**

請採取下列動作：

1. 如果在另一部光碟播放器或 DVD 播放器中可以讀取您的 CD 或 DVD 光碟，或您可看到先前的階段作業，表示磁區上的目錄資訊可能損壞了，所以無法讀取該光碟。如果您想知道如何進行疑難排解，請查看軟體所檢附的說明文件。
2. 您的 CD-R、CD-RW、DVD-R、DVD-RW、DVD+R、DVD+RW 或 DVD-RAM 光碟可能損壞了。換一片新的光碟或另一種品牌的 CD 或 DVD 光碟試試看。
3. 如果您可在寫入光碟機中讀取 CD-RW、DVD-RW、DVD+RW 或 DVD-RAM 光碟，但無法在另一部 MR 光碟機中讀取同一片光碟，請確認電腦是否安裝「UDF Reader」程式。
4. 如果不是受限於電腦的要求，請盡量不要以低於 1X 的速度執行寫入作業。

---

## 附錄 A. 產品規格

本附錄包含下列資訊：

- 實體規格
- 電源需求
- 環境需求
- 讀取速度
- 寫入速度

### 實體規格

本光碟機的實體規格<sup>1</sup>列於下表。

實體規格	
高度	12.7 公釐 (0.5 英吋)
寬度	128 公釐 (5 英吋)
長度	129 公釐 (5.09 英吋)
重量	210 公克 (0.42 磅)

### 電源需求

下表列有以電壓等級表示的光碟機電源規格。電源規格以光碟機電源接頭位置測得之數據為準，並且是額定值。

電源規格	電壓	平均值	最大值
電壓位於	DC 5V	1100 mA	1800 mA

### 環境需求

規格	操作中	非操作中
溫度 (非凝結時)	+5° C 到 +50° C (+41° F 到 +122° F)	-20° C 到 +60° C (-4° F 到 +140° F)
相對濕度 (非凝結時)	10% 到 80%	5% 到 90%

---

1. 產品說明資料代表 IBM 的設計目標，並以比較之用；不同因素可能造成不同的實際結果。本產品資料並不作為保證用途。資料若有異動，恕不另行通知。

## 讀取速度

媒體	讀取速度
CD 光碟機	最快速度：24X
CD-DA (DAE)	最快速度：20X
CD-R	最快速度：24X
CD-RW	最快速度：24X
DVD 光碟機 (單層)	最快速度：8X
DVD 光碟機 (雙層)	最快速度：6X
DVD-R (4.7 GB)	最快速度：8X
DVD+R	最快速度：8X
DVD-RW (4.7 GB)	最快速度：6X
DVD+RW	最快速度：6X
DVD-RAM (4.7/9.4 GB)	最快速度：3X

## 寫入速度

媒體類型	寫入速度
CD-R	最快速度：24X
CD-RW	4X
高速度 CD-RW	10X
超高速 CD-RW	16X
DVD-R	最快速度：8X
DVD+R	最快速度：8X
DVD-RW	最快速度：4X
DVD+RW	最快速度：4X
DVD-RAM	最快速度：3X

---

## 附錄 B. Service and Support

The following information describes the technical support that is available for your product, during the warranty period or throughout the life of the product. Refer to your IBM Statement of Limited Warranty for a full explanation of IBM warranty terms.

---

### Online technical support

Online technical support is available during the life of your product through the Personal Computing Support Web site at <http://www.ibm.com/pc/support>.

During the warranty period, assistance for replacement or exchange of defective components is available. In addition, if your IBM option is installed in an IBM computer, you might be entitled to service at your location. Your technical support representative can help you determine the best alternative.

---

### Telephone technical support

Installation and configuration support through the IBM Support Center will be withdrawn or made available for a fee, at IBM's discretion, 90 days after the option has been withdrawn from marketing. Additional support offerings, including step-by-step installation assistance, are available for a nominal fee.

To assist the technical support representative, have available as much of the following information as possible:

- Option name
- Option number
- Proof of purchase
- Computer manufacturer, model, serial number (if IBM), and manual
- Exact wording of the error message (if any)
- Description of the problem
- Hardware and software configuration information for your system

If possible, be at your computer. Your technical support representative might want to walk you through the problem during the call.

For the support telephone number and support hours by country, refer to the following table. If the number for your country or region is not listed, contact your IBM reseller or IBM marketing representative. Response time may vary depending on the number and nature of the calls received.

Phone numbers are subject to change without notice. For the latest phone number list, go to <http://www.ibm.com/pc/support> and click **Support Phone List**.

Country or Region	Telephone Number	Country or Region	Telephone Number
Africa	+44 (0) 1475 555 055	Japan	Desktop: 0120-887-870 <ul style="list-style-type: none"> <li>Overseas calls: 81-46-266-1084</li> </ul> ThinkPad: 0120-887-874 <ul style="list-style-type: none"> <li>Overseas calls: 81-46-266-1084</li> </ul> IntelliStation and xSeries: 81-46-266-1358 PC Software: 0120-558-695 <ul style="list-style-type: none"> <li>Overseas calls: 81-44-200-8666</li> </ul>
Argentina	0800-666-0011	Luxembourg	298-977-5063
Australia	131-426	Malaysia	(60) 3-7727-7800
Austria	01-24592-5901	Mexico	001-866-434-2080
Bolivia	0800-0189	Middle East	+44 (0) 1475 555 055
Belgium	Dutch: 02-210 9820 French: 02-210 9800	Netherlands	020-514 5770
Brazil	55-11-3889-8986	New Zealand	0800-446-149
Canada	English: 1-800-565-3344 French: 1-800-565-3344 In Toronto: 416-383-3344	Nicaragua	255-6658
Chile	800-224-488	Norway	66 81 11 00
China	800-810-1818	Panama	206-6047
China (Hong Kong and S.A.R.)	Home PC: 852-2825-7799 Commercial PC: 852-8205-0333	Peru	0-800-50-866
Colombia	980-912-3021	Philippines	(63) 2-995-2225
Costa Rica	284-3911	Portugal	21-892-7147
Denmark	45 20 82 00	Russia	095-940-2000
Dominican Republic	566-4755 or 566-5161 ext. 8201 Toll Free within the Dominican Republic: 1-200-1929	Singapore	(65) 1-800-840-9911
Ecuador	1-800-426911 (option #4)	Spain	91-714-7983



Country or Region	Telephone Number	Country or Region	Telephone Number
El Salvador	250-5696	Sweden	08-477 4420
Finland	09-459 69 60	Switzerland	058-333-0900
France	02 38 55 74 50	Taiwan	886-2-8723-9799
Germany	07032-1549 201	Thailand	(66) 2-273-4000
Guatemala	335-8490	Turkey	00-800-446-32-041
Honduras	Tegucigalpa & Sand Pedro Sula: 232-4222  San Pedro Sula: 552-2234	United Kingdom	0-1475-555 055
India	1600-44-6666	United States	1-800-IBM-SERV  (1-800-426-7378)
Indonesia	(62) 21-523-8535	Uruguay	000-411-005-6649
Ireland	02-7031-6101	Venezuela	0-800-100-2011
Italy	01-815-9202	Vietnam	Ho Chi Minh: (84) 8-829-5160  Hanoi: (84) 4-843-6675



---

## 附錄 C. IBM Statement of Limited Warranty Z125-4753-08 04/2004

---

### Part 1 - General Terms

*This Statement of Limited Warranty includes Part 1 - General Terms, Part 2 - Country-unique Terms, and Part 3 - Warranty Information. The terms of Part 2 replace or modify those of Part 1. The warranties provided by IBM in this Statement of Limited Warranty apply only to Machines you purchase for your use, and not for resale. The term "Machine" means an IBM machine, its features, conversions, upgrades, elements, or accessories, or any combination of them. The term "Machine" does not include any software programs, whether pre-loaded with the Machine, installed subsequently or otherwise.* **Nothing in this Statement of Limited Warranty affects any statutory rights of consumers that cannot be waived or limited by contract.**

#### What this Warranty Covers

*IBM warrants that each Machine 1) is free from defects in materials and workmanship and 2) conforms to IBM's Official Published Specifications ("Specifications") which are available on request. The warranty period for the Machine starts on the original Date of Installation and is specified in Part 3 - Warranty Information. The date on your invoice or sales receipt is the Date of Installation unless IBM or your reseller informs you otherwise. Many features, conversions, or upgrades involve the removal of parts and their return to IBM. A part that replaces a removed part will assume the warranty service status of the removed part. Unless IBM specifies otherwise, these warranties apply only in the country or region in which you purchased the Machine.* **THESE WARRANTIES ARE YOUR EXCLUSIVE WARRANTIES AND REPLACE ALL OTHER WARRANTIES OR CONDITIONS, EXPRESS OR IMPLIED, INCLUDING, BUT NOT LIMITED TO, THE IMPLIED WARRANTIES OR CONDITIONS OF MERCHANTABILITY AND FITNESS FOR A PARTICULAR PURPOSE. SOME STATES OR JURISDICTIONS DO NOT ALLOW THE EXCLUSION OF EXPRESS OR IMPLIED WARRANTIES, SO THE ABOVE EXCLUSION MAY NOT APPLY TO YOU. IN THAT EVENT, SUCH WARRANTIES ARE LIMITED IN DURATION TO THE WARRANTY PERIOD. NO WARRANTIES APPLY AFTER THAT PERIOD. SOME STATES OR JURISDICTIONS DO NOT ALLOW LIMITATIONS ON HOW LONG AN IMPLIED WARRANTY LASTS, SO THE ABOVE LIMITATION MAY NOT APPLY TO YOU.**

#### What this Warranty Does not Cover

This warranty does not cover the following:

- any software programs, whether pre-loaded or shipped with the Machine, or installed subsequently;
- failure resulting from misuse (including but not limited to use of any Machine capacity or capability, other than that authorized by IBM in writing), accident, modification, unsuitable physical or operating environment, or improper maintenance by you;
- failure caused by a product for which IBM is not responsible; and
- any non-IBM products, including those that IBM may procure and provide with or integrate into an IBM Machine at your request.

The warranty is voided by removal or alteration of identification labels on the Machine or its parts.

IBM does not warrant uninterrupted or error-free operation of a Machine.

Any technical or other support provided for a Machine under warranty, such as assistance with "how-to" questions and those regarding Machine set-up and installation, is provided **WITHOUT WARRANTIES OF ANY KIND.**

### **How to Obtain Warranty Service**

If the Machine does not function as warranted during the warranty period, contact IBM or your reseller to obtain warranty service. If you do not register the Machine with IBM, you may be required to present proof of purchase as evidence of your entitlement to warranty service.

### **What IBM Will Do to Correct Problems**

When you contact IBM for service, you must follow the problem determination and resolution procedures that IBM specifies. An initial diagnosis of your problem can be made either by a technician over the telephone or electronically by access to an IBM website. The type of warranty service applicable to your Machine is specified in Part 3 - Warranty Information. You are responsible for downloading and installing designated Machine Code (microcode, basic input/output system code (called "BIOS"), utility programs, device drivers, and diagnostics delivered with an IBM Machine ) and other software updates from an IBM Internet Web site or from other electronic media, and following the instructions that IBM provides. If your problem can be resolved with a Customer Replaceable Unit ("CRU") (e.g., keyboard, mouse, speaker, memory, hard disk drive), IBM will ship the CRU to you for you to install. If the Machine does not function as warranted during the warranty period and your problem cannot be resolved over the telephone or electronically, through your application of Machine Code or software updates, or with a CRU, IBM or your reseller, if approved by IBM to provide warranty service, will either, at its discretion, 1) repair it to make it function as warranted, or 2) replace it with one that is at least functionally equivalent. If IBM is unable to do either, you may return the Machine to your place of purchase and your money will be refunded. IBM or your reseller will also manage and install selected engineering changes that apply to the Machine.

### **Exchange of a Machine or Part**

When the warranty service involves the exchange of a Machine or part, the item IBM or your reseller replaces becomes its property and the replacement becomes yours. You represent that all removed items are genuine and unaltered. The replacement may not be new, but will be in good working order and at least functionally equivalent to the item replaced. The replacement assumes the warranty service status of the replaced item.

### **Your Additional Responsibilities**

Before IBM or your reseller exchanges a Machine or part, you agree to remove all features, parts, options, alterations, and attachments not under warranty service.

You also agree to:

1. ensure that the Machine is free of any legal obligations or restrictions that prevent its exchange;
2. obtain authorization from the owner to have IBM or your reseller service a Machine that you do not own; and

3. where applicable, before service is provided:
  - a. follow the service request procedures that IBM or your reseller provides;
  - b. backup or secure all programs, data, and funds contained in the Machine;
  - c. provide IBM or your reseller with sufficient, free, and safe access to your facilities to permit IBM to fulfill its obligations; and
  - d. inform IBM or your reseller of changes in the Machine's location.
4. (a) ensure all information about identified or identifiable individuals (Personal Data) is deleted from the Machine (to the extent technically possible), (b) allow IBM, your reseller or an IBM supplier to process on your behalf any remaining Personal Data as IBM or your reseller considers necessary to fulfill its obligations under this Statement of Limited Warranty (which may include shipping the Machine for such processing to other IBM service locations around the world), and (c) ensure that such processing complies with any laws applicable to such Personal Data.

### **Limitation of Liability**

IBM is responsible for loss of, or damage to, your Machine only while it is 1) in IBM's possession or 2) in transit in those cases where IBM is responsible for the transportation charges.

Neither IBM nor your reseller are responsible for any of your confidential, proprietary or personal information contained in a Machine which you return to IBM for any reason. You should remove all such information from the Machine prior to its return.

Circumstances may arise where, because of a default on IBM's part or other liability, you are entitled to recover damages from IBM. In each such instance, regardless of the basis on which you are entitled to claim damages from IBM (including fundamental breach, negligence, misrepresentation, or other contract or tort claim), except for any liability that cannot be waived or limited by applicable laws, IBM is liable for no more than

1. damages for bodily injury (including death) and damage to real property and tangible personal property; and
2. the amount of any other actual direct damages, up to the charges (if recurring, 12 months' charges apply) for the Machine that is subject of the claim. For purposes of this item, the term "Machine" includes Machine Code and Licensed Internal Code ("LIC").

This limit also applies to IBM's suppliers and your reseller. It is the maximum for which IBM, its suppliers, and your reseller are collectively responsible.

**UNDER NO CIRCUMSTANCES IS IBM, ITS SUPPLIERS OR RESELLERS LIABLE FOR ANY OF THE FOLLOWING EVEN IF INFORMED OF THEIR POSSIBILITY: 1) THIRD PARTY CLAIMS AGAINST YOU FOR DAMAGES (OTHER THAN THOSE UNDER THE FIRST ITEM LISTED ABOVE); 2) LOSS OF, OR DAMAGE TO, DATA; 3) SPECIAL, INCIDENTAL, OR INDIRECT DAMAGES OR FOR ANY ECONOMIC CONSEQUENTIAL DAMAGES; OR 4) LOST PROFITS, BUSINESS REVENUE, GOODWILL OR ANTICIPATED SAVINGS. SOME STATES OR JURISDICTIONS DO NOT ALLOW THE EXCLUSION OR LIMITATION OF INCIDENTAL OR CONSEQUENTIAL DAMAGES, SO THE ABOVE LIMITATION OR EXCLUSION MAY NOT APPLY TO YOU. SOME STATES OR JURISDICTIONS DO NOT ALLOW LIMITATIONS ON HOW LONG AN IMPLIED WARRANTY LASTS, SO THE ABOVE LIMITATION MAY NOT APPLY TO YOU.**

### **Governing Law**

Both you and IBM consent to the application of the laws of the country in which you acquired the Machine to govern, interpret, and enforce all of your and IBM's rights, duties, and obligations arising from, or relating in any manner to, the subject matter of this Statement of Limited Warranty, without regard to conflict of law principles.

**THESE WARRANTIES GIVE YOU SPECIFIC LEGAL RIGHTS AND YOU MAY ALSO HAVE OTHER RIGHTS WHICH VARY FROM STATE TO STATE OR JURISDICTION TO JURISDICTION.**

### **Jurisdiction**

All of our rights, duties, and obligations are subject to the courts of the country in which you acquired the Machine.

---

## **Part 2 - Country-unique Terms**

### **AMERICAS**

#### **ARGENTINA**

**Jurisdiction:** *The following is added after the first sentence:*

Any litigation arising from this Statement of Limited Warranty will be settled exclusively by the Ordinary Commercial Court of the city of Buenos Aires.

#### **BOLIVIA**

**Jurisdiction:** *The following is added after the first sentence:*

Any litigation arising from this Statement of Limited Warranty will be settled exclusively by the courts of the city of La Paz.

#### **BRAZIL**

**Jurisdiction:** *The following is added after the first sentence:*

Any litigation arising from this Agreement will be settled exclusively by the court of Rio de Janeiro, RJ.

#### **CHILE**

**Jurisdiction:** *The following is added after the first sentence:*

Any litigation arising from this Statement of Limited Warranty will be settled exclusively by the Civil Courts of Justice of Santiago.

#### **COLOMBIA**

**Jurisdiction:** *The following is added after the first sentence:*

Any litigation arising from this Statement of Limited Warranty will be settled exclusively by the Judges of the Republic of Colombia.

#### **EQUADOR**

**Jurisdiction:** *The following is added after the first sentence:*

Any litigation arising from this Statement of Limited Warranty will be settled exclusively by the Judges of Quito.

#### **MEXICO**

**Jurisdiction:** *The following is added after the first sentence:*

Any litigation arising from this Statement of Limited Warranty will be settled exclusively by the Federal Courts of Mexico City, Federal District.

#### **PARAGUAY**

**Jurisdiction:** *The following is added after the first sentence:*

Any litigation arising from this Statement of Limited Warranty will be settled exclusively by the courts of the city of Asuncion.

#### **PERU**

**Jurisdiction:** *The following is added after the first sentence:*

Any litigation arising from this Statement of Limited Warranty will be settled exclusively by the Judges and Tribunals of the Judicial District of Lima, Cercado.

**Limitation of Liability:** *The following is added at the end of this section:* In accordance with Article 1328 of the Peruvian Civil Code the limitations and exclusions specified in this section will not apply to damages caused by IBM's willful misconduct ("dolo") or gross negligence ("culpa inexcusable").

#### **URUGUAY**

**Jurisdiction:** *The following is added after the first sentence:*

Any litigation arising from this Statement of Limited Warranty will be settled exclusively by the City of Montevideo Court's Jurisdiction.

#### **VENEZUELA**

**Jurisdiction:** *The following is added after the first sentence:*

Any litigation arising from this Statement of Limited Warranty will be settled exclusively by the Courts of the Metropolitan Area Of the City of Caracas.

#### **NORTH AMERICA**

**How to Obtain Warranty Service:** *The following is added to this Section:*

To obtain warranty service from IBM in Canada or the United States, call 1-800-IBM-SERV (426-7378).

#### **CANADA**

**Limitation of Liability:** *The following replaces item 1 of this section:*

1. damages for bodily injury (including death) or physical harm to real property and tangible personal property caused by IBM's negligence; and

**Governing Law:** *The following replaces "laws of the country in which you acquired the Machine" in the first sentence:*

laws in the Province of Ontario.

#### **UNITED STATES**

**Governing Law:** *The following replaces "laws of the country in which you acquired the Machine" in the first sentence:*

laws of the State of New York.

#### **ASIA PACIFIC**

#### **AUSTRALIA**

**What this Warranty Covers:** *The following paragraph is added to this Section:*

The warranties specified in this Section are in addition to any rights you may have under

the Trade Practices Act 1974 or other similar legislation and are only limited to the extent permitted by the applicable legislation.

**Limitation of Liability:** *The following is added to this Section:*

Where IBM is in breach of a condition or warranty implied by the Trade Practices Act 1974 or other similar legislation, IBM's liability is limited to the repair or replacement of the goods or the supply of equivalent goods. Where that condition or warranty relates to right to sell, quiet possession or clear title, or the goods are of a kind ordinarily acquired for personal, domestic or household use or consumption, then none of the limitations in this paragraph apply.

**Governing Law:** *The following replaces "laws of the country in which you acquired the Machine" in the first sentence:*

laws of the State or Territory.

## **CAMBODIA AND LAOS**

**Governing Law:** *The following replaces "laws of the country in which you acquired the Machine" in the first sentence:*

laws of the State of New York, United States of America.

## **CAMBODIA, INDONESIA, AND LAOS**

**Arbitration:** *The following is added under this heading:*

Disputes arising out of or in connection with this Statement of Limited Warranty shall be finally settled by arbitration which shall be held in Singapore in accordance with the Arbitration Rules of Singapore International Arbitration Center ("SIAC Rules") then in effect. The arbitration award shall be final and binding for the parties without appeal and shall be in writing and set forth the findings of fact and the conclusions of law. The number of arbitrators shall be three, with each side to the dispute being entitled to appoint one arbitrator. The two arbitrators appointed by the parties shall appoint a third arbitrator who shall act as chairman of the proceedings. Vacancies in the post of chairman shall be filled by the president of the SIAC. Other vacancies shall be filled by the respective nominating party. Proceedings shall continue from the stage they were at when the vacancy occurred. If one of the parties refuses or otherwise fails to appoint an arbitrator within 30 days of the date the other party appoints its, the first appointed arbitrator shall be the sole arbitrator, provided that the arbitrator was validly and properly appointed. All proceedings shall be conducted, including all documents presented in such proceedings, in the English language. The English language version of this Statement of Limited Warranty prevails over any other language version.

## **HONG KONG S.A.R. OF CHINA AND MACAU S.A.R. OF CHINA**

**Governing Law:** *The following replaces "laws of the country in which you acquired the Machine" in the first sentence:*

laws of Hong Kong Special Administrative Region of China.

## **INDIA**

**Limitation of Liability:** *The following replaces items 1 and 2 of this Section:*

1. liability for bodily injury (including death) or damage to real property and tangible personal property will be limited to that caused by IBM's negligence; and
2. as to any other actual damage arising in any situation involving nonperformance by IBM pursuant to, or in any way related to the subject of this Statement of Limited



Warranty, the charge paid by you for the individual Machine that is the subject of the claim. For purposes of this item, the term "Machine" includes Machine Code and Licensed Internal Code ("LIC").

**Arbitration:** *The following is added under this heading*

Disputes arising out of or in connection with this Statement of Limited Warranty shall be finally settled by arbitration which shall be held in Bangalore, India in accordance with the laws of India then in effect. The arbitration award shall be final and binding for the parties without appeal and shall be in writing and set forth the findings of fact and the conclusions of law. The number of arbitrators shall be three, with each side to the dispute being entitled to appoint one arbitrator. The two arbitrators appointed by the parties shall appoint a third arbitrator who shall act as chairman of the proceedings. Vacancies in the post of chairman shall be filled by the president of the Bar Council of India. Other vacancies shall be filled by the respective nominating party. Proceedings shall continue from the stage they were at when the vacancy occurred. If one of the parties refuses or otherwise fails to appoint an arbitrator within 30 days of the date the other party appoints its, the first appointed arbitrator shall be the sole arbitrator, provided that the arbitrator was validly and properly appointed. All proceedings shall be conducted, including all documents presented in such proceedings, in the English language. The English language version of this Statement of Limited Warranty prevails over any other language version.

**JAPAN**

**Governing Law:** *The following sentence is added to this Section:*

Any doubts concerning this Statement of Limited Warranty will be initially resolved between us in good faith and in accordance with the principle of mutual trust.

**MALAYSIA**

**Limitation of Liability:** The word "**SPECIAL**" in item 3 of the fifth paragraph is deleted.

**NEW ZEALAND**

**What this Warranty Covers:** *The following paragraph is added to this Section:*

The warranties specified in this section are in addition to any rights you may have under the Consumer Guarantees Act 1993 or other legislation which cannot be excluded or limited. The Consumer Guarantees Act 1993 will not apply in respect of any goods which IBM provides, if you require the goods for the purposes of a business as defined in that Act.

**Limitation of Liability:** *The following is added to this Section:*

Where Machines are not acquired for the purposes of a business as defined in the Consumer Guarantees Act 1993, the limitations in this Section are subject to the limitations in that Act.

**PEOPLE'S REPUBLIC OF CHINA (PRC)**

**Governing Law:** *The following replaces "laws of the country in which you acquired the Machine" in the first sentence:*

laws of the State of New York, United States of America (except when local law requires otherwise).

**PHILIPPINES**

**Limitation of Liability:** *Item 3 in the fifth paragraph is replaced by the following:*

**SPECIAL (INCLUDING NOMINAL AND EXEMPLARY DAMAGES), MORAL,**

## **INCIDENTAL, OR INDIRECT DAMAGES FOR ANY ECONOMIC CONSEQUENTIAL DAMAGES; OR**

**Arbitration:** The following is added: under this heading

Disputes arising out of or in connection with this Statement of Limited Warranty shall be finally settled by arbitration which shall be held in Metro Manila, Philippines in accordance with the laws of the Philippines then in effect. The arbitration award shall be final and binding for the parties without appeal and shall be in writing and set forth the findings of fact and the conclusions of law. The number of arbitrators shall be three, with each side to the dispute being entitled to appoint one arbitrator. The two arbitrators appointed by the parties shall appoint a third arbitrator who shall act as chairman of the proceedings. Vacancies in the post of chairman shall be filled by the president of the Philippine Dispute Resolution Center, Inc.. Other vacancies shall be filled by the respective nominating party. Proceedings shall continue from the stage they were at when the vacancy occurred. If one of the parties refuses or otherwise fails to appoint an arbitrator within 30 days of the date the other party appoints its, the first appointed arbitrator shall be the sole arbitrator, provided that the arbitrator was validly and properly appointed. All proceedings shall be conducted, including all documents presented in such proceedings, in the English language. The English language version of this Statement of Limited Warranty prevails over any other language version.

## **SINGAPORE**

**Limitation of Liability:** *The words "SPECIAL" and "ECONOMIC" in item 3 in the fifth paragraph are deleted.*

## **EUROPE, MIDDLE EAST, AFRICA (EMEA)**

### **THE FOLLOWING TERMS APPLY TO ALL EMEA COUNTRIES:**

The terms of this Statement of Limited Warranty apply to Machines purchased from IBM or an IBM reseller.

### **How to Obtain Warranty Service:**

*Add the following paragraph in **Western Europe** (Andorra, Austria, Belgium, Cyprus, Czech Republic, Denmark, Estonia, Finland, France, Germany, Greece, Hungary, Iceland, Ireland, Italy, Latvia, Liechtenstein, Lithuania, Luxembourg, Malta, Monaco, Netherlands, Norway, Poland, Portugal, San Marino, Slovakia, Slovenia, Spain, Sweden, Switzerland, United Kingdom, Vatican State, and any country subsequently added to the European Union, as from the date of accession):* The warranty for Machines acquired in Western Europe shall be valid and applicable in all Western Europe countries provided the Machines have been announced and made available in such countries. If you purchase a Machine in one of the Western European countries, as defined above, you may obtain warranty service for that Machine in any of those countries from either (1) an IBM reseller approved to perform warranty service or (2) from IBM, provided the Machine has been announced and made available by IBM in the country in which you wish to obtain service. If you purchased a Personal Computer Machine in Albania, Armenia, Belarus, Bosnia and Herzegovina, Bulgaria, Croatia, Czech Republic, Georgia, Hungary, Kazakhstan, Kyrgyzstan, Federal Republic of Yugoslavia, Former Yugoslav Republic of Macedonia (FYROM), Moldova, Poland, Romania, Russia, Slovak Republic, Slovenia, or Ukraine, you may obtain warranty service for that Machine in any of those countries from either (1) an IBM reseller approved to perform warranty service or (2) from IBM. If you purchase a Machine in

a Middle Eastern or African country, you may obtain warranty service for that Machine from the IBM entity within the country of purchase, if that IBM entity provides warranty service in that country, or from an IBM reseller, approved by IBM to perform warranty service on that Machine in that country. Warranty service in Africa is available within 50 kilometers of an IBM approved service provider. You are responsible for transportation costs for Machines located outside 50 kilometers of an IBM approved service provider.

#### **Governing Law:**

*The phrase "the laws of the country in which you acquired the Machine" is replaced by:*

1) "the laws of Austria" in **Albania, Armenia, Azerbaijan, Belarus, Bosnia-Herzegovina, Bulgaria, Croatia, Georgia, Hungary, Kazakhstan, Kyrgyzstan, FYR Macedonia, Moldova, Poland, Romania, Russia, Slovakia, Slovenia, Tajikistan, Turkmenistan, Ukraine, Uzbekistan, and FR Yugoslavia;** 2) "the laws of France" in **Algeria, Benin, Burkina Faso, Cameroon, Cape Verde, Central African Republic, Chad, Comoros, Congo Republic, Djibouti, Democratic Republic of Congo, Equatorial Guinea, French Guiana, French Polynesia, Gabon, Gambia, Guinea, Guinea-Bissau, Ivory Coast, Lebanon, Madagascar, Mali, Mauritania, Mauritius, Mayotte, Morocco, New Caledonia, Niger, Reunion, Senegal, Seychelles, Togo, Tunisia, Vanuatu, and Wallis & Futuna;** 3) "the laws of Finland" in **Estonia, Latvia, and Lithuania;** 4) "the laws of England" in **Angola, Bahrain, Botswana, Burundi, Egypt, Eritrea, Ethiopia, Ghana, Jordan, Kenya, Kuwait, Liberia, Malawi, Malta, Mozambique, Nigeria, Oman, Pakistan, Qatar, Rwanda, Sao Tome, Saudi Arabia, Sierra Leone, Somalia, Tanzania, Uganda, United Arab Emirates, the United Kingdom, West Bank/Gaza, Yemen, Zambia, and Zimbabwe;** and 5) "the laws of South Africa" in **South Africa, Namibia, Lesotho and Swaziland.**

**Jurisdiction:** *The following exceptions are added to this section:*

1) **In Austria** the choice of jurisdiction for all disputes arising out of this Statement of Limited Warranty and relating thereto, including its existence, will be the competent court of law in Vienna, Austria (Inner-City); 2) **in Angola, Bahrain, Botswana, Burundi, Egypt, Eritrea, Ethiopia, Ghana, Jordan, Kenya, Kuwait, Liberia, Malawi, Malta, Mozambique, Nigeria, Oman, Pakistan, Qatar, Rwanda, Sao Tome, Saudi Arabia, Sierra Leone, Somalia, Tanzania, Uganda, United Arab Emirates, West Bank/Gaza, Yemen, Zambia, and Zimbabwe** all disputes arising out of this Statement of Limited Warranty or related to its execution, including summary proceedings, will be submitted to the exclusive jurisdiction of the English courts; 3) in **Belgium and Luxembourg**, all disputes arising out of this Statement of Limited Warranty or related to its interpretation or its execution, the law, and the courts of the capital city, of the country of your registered office and/or commercial site location only are competent; 4) **in France, Algeria, Benin, Burkina Faso, Cameroon, Cape Verde, Central African Republic, Chad, Comoros, Congo Republic, Djibouti, Democratic Republic of Congo, Equatorial Guinea, French Guiana, French Polynesia, Gabon, Gambia, Guinea, Guinea-Bissau, Ivory Coast, Lebanon, Madagascar, Mali, Mauritania, Mauritius, Mayotte, Morocco, New Caledonia, Niger, Reunion, Senegal, Seychelles, Togo, Tunisia, Vanuatu, and Wallis & Futuna** all disputes arising out of this Statement of Limited Warranty or related to its violation or execution, including summary proceedings, will be settled exclusively by the Commercial Court of Paris; 5)

in **Russia**, all disputes arising out of or in relation to the interpretation, the violation, the termination, the nullity of the execution of this Statement of Limited Warranty shall be settled by Arbitration Court of Moscow; 6) **in South Africa, Namibia, Lesotho and Swaziland**, both of us agree to submit all disputes relating to this Statement of Limited Warranty to the jurisdiction of the High Court in Johannesburg; 7) **in Turkey** all disputes arising out of or in connection with this Statement of Limited Warranty shall be resolved by the Istanbul Central (Sultanahmet) Courts and Execution Directorates of Istanbul, the Republic of Turkey; 8) in each of the following specified countries, any legal claim arising out of this Statement of Limited Warranty will be brought before, and settled exclusively by, the competent court of a) Athens for **Greece**, b) Tel Aviv-Jaffa for **Israel**, c) Milan for **Italy**, d) Lisbon for **Portugal**, and e) Madrid for **Spain**; and 9) **in the United Kingdom**, both of us agree to submit all disputes relating to this Statement of Limited Warranty to the jurisdiction of the English courts.

**Arbitration:** *The following is added under this heading:*

**In Albania, Armenia, Azerbaijan, Belarus, Bosnia-Herzegovina, Bulgaria, Croatia, Georgia, Hungary, Kazakhstan, Kyrgyzstan, FYR Macedonia, Moldova, Poland, Romania, Russia, Slovakia, Slovenia, Tajikistan, Turkmenistan, Ukraine, Uzbekistan, and FR Yugoslavia** all disputes arising out of this Statement of Limited Warranty or related to its violation, termination or nullity will be finally settled under the Rules of Arbitration and Conciliation of the International Arbitral Center of the Federal Economic Chamber in Vienna (Vienna Rules) by three arbitrators appointed in accordance with these rules. The arbitration will be held in Vienna, Austria, and the official language of the proceedings will be English. The decision of the arbitrators will be final and binding upon both parties. Therefore, pursuant to paragraph 598 (2) of the Austrian Code of Civil Procedure, the parties expressly waive the application of paragraph 595 (1) figure 7 of the Code. IBM may, however, institute proceedings in a competent court in the country of installation. **In Estonia, Latvia and Lithuania** all disputes arising in connection with this Statement of Limited Warranty will be finally settled in arbitration that will be held in Helsinki, Finland in accordance with the arbitration laws of Finland then in effect. Each party will appoint one arbitrator. The arbitrators will then jointly appoint the chairman. If arbitrators cannot agree on the chairman, then the Central Chamber of Commerce in Helsinki will appoint the chairman.

## **EUROPEAN UNION (EU)**

### **THE FOLLOWING TERMS APPLY TO ALL EU COUNTRIES:**

The warranty for Machines acquired in EU countries is valid and applicable in all EU countries provided the Machines have been announced and made available in such countries.

**How to Obtain Warranty Service:** *The following is added to this section:*

To obtain warranty service from IBM in EU countries, see the telephone listing in Part 3 - Warranty Information.

You may contact IBM at the following address:

IBM Warranty & Service Quality Dept.

PO Box 30

Spango Valley

Greenock

Scotland PA16 0AH

## CONSUMERS

Consumers have legal rights under applicable national legislation governing the sale of consumer goods. Such rights are not affected by the warranties provided in this Statement of Limited Warranty.

### **AUSTRIA, DENMARK, FINLAND, GREECE, ITALY, NETHERLANDS, NORWAY, PORTUGAL, SPAIN, SWEDEN AND SWITZERLAND**

**Limitation of Liability:** *The following replaces the terms of this section in its entirety:*  
Except as otherwise provided by mandatory law:

1. IBM's liability for any damages and losses that may arise as a consequence of the fulfillment of its obligations under or in connection with this Statement of Limited Warranty or due to any other cause related to this Statement of Limited Warranty is limited to the compensation of only those damages and losses proved and actually arising as an immediate and direct consequence of the non-fulfillment of such obligations (if IBM is at fault) or of such cause, for a maximum amount equal to the charges you paid for the Machine. For purposes of this item, the term "Machine" includes Machine Code and Licensed Internal Code ("LIC").

The above limitation shall not apply to damages for bodily injuries (including death) and damages to real property and tangible personal property for which IBM is legally liable.

2. **UNDER NO CIRCUMSTANCES IS IBM, ITS SUPPLIERS OR RESELLERS LIABLE FOR ANY OF THE FOLLOWING, EVEN IF INFORMED OF THEIR POSSIBILITY: 1) LOSS OF, OR DAMAGE TO, DATA; 2) INCIDENTAL OR INDIRECT DAMAGES, OR FOR ANY ECONOMIC CONSEQUENTIAL DAMAGES; 3) LOST PROFITS, EVEN IF THEY ARISE AS AN IMMEDIATE CONSEQUENCE OF THE EVENT THAT GENERATED THE DAMAGES; OR 4) LOSS OF BUSINESS, REVENUE, GOODWILL, OR ANTICIPATED SAVINGS.**

### **FRANCE AND BELGIUM**

**Limitation of Liability:** *The following replaces the terms of this section in its entirety:*  
Except as otherwise provided by mandatory law:

1. IBM's liability for any damages and losses that may arise as a consequence of the fulfillment of its obligations under or in connection with this Statement of Limited Warranty is limited to the compensation of only those damages and losses proved and actually arising as an immediate and direct consequence of the non-fulfillment of such obligations (if IBM is at fault), for a maximum amount equal to the charges you paid for the Machine that has caused the damages. For purposes of this item, the term "Machine" includes Machine Code and Licensed Internal Code ("LIC").

The above limitation shall not apply to damages for bodily injuries (including death) and damages to real property and tangible personal property for which IBM is legally liable.

2. **UNDER NO CIRCUMSTANCES IS IBM, ITS SUPPLIERS OR RESELLERS LIABLE FOR ANY OF THE FOLLOWING, EVEN IF INFORMED OF THEIR POSSIBILITY: 1) LOSS OF, OR DAMAGE TO, DATA; 2) INCIDENTAL OR INDIRECT DAMAGES, OR FOR ANY ECONOMIC CONSEQUENTIAL DAMAGES; 3) LOST PROFITS, EVEN IF THEY ARISE AS AN IMMEDIATE CONSEQUENCE OF THE EVENT THAT GENERATED THE DAMAGES; OR 4) LOSS OF BUSINESS, REVENUE, GOODWILL, OR ANTICIPATED SAVINGS.**

## THE FOLLOWING TERMS APPLY TO THE COUNTRY SPECIFIED:

### AUSTRIA

**The provisions of this Statement of Limited Warranty replace any applicable statutory warranties.**

**What this Warranty Covers:** *The following replaces the first sentence of the first paragraph of this section:*

The warranty for an IBM Machine covers the functionality of the Machine for its normal use and the Machine's conformity to its Specifications.

*The following paragraphs are added to this section:*

The limitation period for consumers in action for breach of warranty is the statutory period as a minimum. In case IBM or your reseller is unable to repair an IBM Machine, you can alternatively ask for a partial refund as far as justified by the reduced value of the unrepaired Machine or ask for a cancellation of the respective agreement for such Machine and get your money refunded.

*The second paragraph does not apply.*

**What IBM Will Do to Correct Problems:** *The following is added to this section:*

During the warranty period, IBM will reimburse you for the transportation charges for the delivery of the failing Machine to IBM.

**Limitation of Liability:** *The following paragraph is added to this section:*

The limitations and exclusions specified in the Statement of Limited Warranty will not apply to damages caused by IBM with fraud or gross negligence and for express warranty.

*The following sentence is added to the end of item 2:*

IBM's liability under this item is limited to the violation of essential contractual terms in cases of ordinary negligence.

### EGYPT

**Limitation of Liability:** *The following replaces item 2 in this section:*

as to any other actual direct damages, IBM's liability will be limited to the total amount you paid for the Machine that is the subject of the claim. For purposes of this item, the term "Machine" includes Machine Code and Licensed Internal Code ("LIC").

*Applicability of suppliers and resellers (unchanged).*

### FRANCE

**Limitation of Liability:** *The following replaces the second sentence of the first paragraph of this section:*

In such instances, regardless of the basis on which you are entitled to claim damages from IBM, IBM is liable for no more than: (items 1 and 2 unchanged).

### GERMANY

**What this Warranty Covers:** *The following replaces the first sentence of the first paragraph of this section:*

The warranty for an IBM Machine covers the functionality of the Machine for its normal use and the Machine's conformity to its Specifications.

*The following paragraphs are added to this section:*

The minimum warranty period for Machines is twelve months. In case IBM or your reseller is unable to repair an IBM Machine, you can alternatively ask for a partial refund as far as justified by the reduced value of the unrepaired Machine or ask for a cancellation



of the respective agreement for such Machine and get your money refunded.

*The second paragraph does not apply.*

**What IBM Will Do to Correct Problems:** *The following is added to this section:*

During the warranty period, transportation for delivery of the failing Machine to IBM will be at IBM's expense.

**Limitation of Liability:** *The following paragraph is added to this section:*

The limitations and exclusions specified in the Statement of Limited Warranty will not apply to damages caused by IBM with fraud or gross negligence and for express warranty.

*The following sentence is added to the end of item 2:*

IBM's liability under this item is limited to the violation of essential contractual terms in cases of ordinary negligence.

## HUNGARY

**Limitation of Liability:** *The following is added at the end of this section:*

The limitation and exclusion specified herein shall not apply to liability for a breach of contract damaging life, physical well-being, or health that has been caused intentionally, by gross negligence, or by a criminal act. The parties accept the limitations of liability as valid provisions and state that the Section 314.(2) of the Hungarian Civil Code applies as the acquisition price as well as other advantages arising out of the present Statement of Limited Warranty balance this limitation of liability.

## IRELAND

**What this Warranty Covers:** *The following is added to this section:*

Except as expressly provided in these terms and conditions, all statutory conditions, including all warranties implied, but without prejudice to the generality of the foregoing all warranties implied by the Sale of Goods Act 1893 or the Sale of Goods and Supply of Services Act 1980 are hereby excluded.

**Limitation of Liability:** *The following replaces the terms of section in its entirety:*

For the purposes of this section, a "Default" means any act, statement, omission, or negligence on the part of IBM in connection with, or in relation to, the subject matter of this Statement of Limited Warranty in respect of which IBM is legally liable to you, whether in contract or tort. A number of Defaults which together result in, or contribute to, substantially the same loss or damage will be treated as one Default occurring on the date of occurrence of the last such Default. Circumstances may arise where, because of a Default, you are entitled to recover damages from IBM. This section sets out the extent of IBM's liability and your sole remedy.

1. IBM will accept unlimited liability for death or personal injury caused by the negligence of IBM
2. Subject always to the **Items for Which IBM is Not Liable** below, IBM will accept unlimited liability for physical damage to your tangible property resulting from the negligence of IBM.
3. Except as provided in items 1 and 2 above, IBM's entire liability for actual damages for any one Default will not in any event exceed the greater of 1) EUR 125,000, or 2) 125% of the amount you paid for the Machine directly relating to the Default.

## Items for Which IBM is Not Liable

Save with respect to any liability referred to in item 1 above, under no circumstances is IBM, its suppliers or resellers liable for any of the following, even if IBM or they were informed of the possibility of such losses:

1. loss of, or damage to, data;
2. special, indirect, or consequential loss; or
3. loss of profits, business, revenue, goodwill, or anticipated savings.

### **SLOVAKIA**

**Limitation of Liability:** *The following is added to the end of the last paragraph:*

The limitations apply to the extent they are not prohibited under §§ 373-386 of the Slovak Commercial Code.

### **SOUTH AFRICA, NAMIBIA, BOTSWANA, LESOTHO AND SWAZILAND**

**Limitation of Liability:** *The following is added to this section:*

IBM's entire liability to you for actual damages arising in all situations involving nonperformance by IBM in respect of the subject matter of this Statement of Warranty will be limited to the charge paid by you for the individual Machine that is the subject of your claim from IBM.

### **UNITED KINGDOM**

**Limitation of Liability:** *The following replaces the terms of this section in its entirety:*

For the purposes of this section, a "Default" means any act, statement, omission, or negligence on the part of IBM in connection with, or in relation to, the subject matter of this Statement of Limited Warranty in respect of which IBM is legally liable to you, whether in contract or tort. A number of Defaults which together result in, or contribute to, substantially the same loss or damage will be treated as one Default. Circumstances may arise where, because of a Default, you are entitled to recover damages from IBM. This section sets out the extent of IBM's liability and your sole remedy.

1. IBM will accept unlimited liability for:
  - a. death or personal injury caused by the negligence of IBM; and
  - b. any breach of its obligations implied by Section 12 of the Sale of Goods Act 1979 or Section 2 of the Supply of Goods and Services Act 1982, or any statutory modification or re-enactment of either such Section.
2. IBM will accept unlimited liability, subject always to the **Items for Which IBM is Not Liable** below, for physical damage to your tangible property resulting from the negligence of IBM.
3. IBM's entire liability for actual damages for any one Default will not in any event, except as provided in items 1 and 2 above, exceed the greater of 1) Pounds Sterling 75,000, or 2) 125% of the total purchase price payable or the charges for the Machine directly relating to the Default.

These limits also apply to IBM's suppliers and resellers. They state the maximum for which IBM and such suppliers and resellers are collectively responsible.

### **Items for Which IBM is Not Liable**

Save with respect to any liability referred to in item 1 above, under no circumstances is IBM or any of its suppliers or resellers liable for any of the following, even if IBM or they were informed of the possibility of such losses:

1. loss of, or damage to, data;
2. special, indirect, or consequential loss; or
3. loss of profits, business, revenue, goodwill, or anticipated savings.



---

## Part 3 - Warranty Information

This Part 3 provides information regarding the warranty applicable to your Machine, including the warranty period and type of warranty service IBM provides.

### Warranty Period

The warranty period may vary by country or region and is specified in the table below. NOTE: "Region" means either Hong Kong or Macau Special Administrative Region of China.

### ThinkPad Multi-Burner Plus Ultrabay Enhanced Drive

Country or Region of Purchase	Warranty Period	Type of Warranty Service
Worldwide	3 years	7

A warranty period of 3 years on parts and 3 years on labor means that IBM provides warranty service without charge for parts and labor during the 3 year warranty period.

## Types of Warranty Service

If required, IBM provides repair or exchange service depending on the type of warranty service specified for your Machine in the above table and as described below. Warranty service may be provided by your reseller if approved by IBM to perform warranty service. Scheduling of service will depend upon the time of your call and is subject to parts availability. Service levels are response time objectives and are not guaranteed. The specified level of warranty service may not be available in all worldwide locations, additional charges may apply outside IBM's normal service area, contact your local IBM representative or your reseller for country and location specific information.

### 1. Customer Replaceable Unit ("CRU") Service

IBM provides replacement CRUs to you for you to install. CRU information and replacement instructions are shipped with your Machine and are available from IBM at any time on your request. Installation of Tier 1 CRUs is your responsibility. If IBM installs a Tier 1 CRU at your request, you will be charged for the installation. You may install a Tier 2 CRU yourself or request IBM to install it, at no additional charge, under the type of warranty service designated for your Machine. IBM specifies in the materials shipped with a replacement CRU whether a defective CRU must be returned to IBM. When return is required, 1) return instructions and a container are shipped with the replacement CRU, and 2) you may be charged for the replacement CRU if IBM does not receive the defective CRU within 30 days of your receipt of the replacement.

### 2. On-site Service

IBM or your reseller will either repair or exchange the failing Machine at your location and verify its operation. You must provide suitable working area to allow disassembly and reassembly of the IBM Machine. The area must be clean, well lit and suitable for the purpose. For some Machines, certain repairs may require sending the Machine to an IBM service center.

### 3. **Courier or Depot Service \***

You will disconnect the failing Machine for collection arranged by IBM. IBM will provide you with a shipping container for you to return your Machine to a designated service center. A courier will pick up your Machine and deliver it to the designated service center. Following its repair or exchange, IBM will arrange the return delivery of the Machine to your location. You are responsible for its installation and verification.

### 4. **Customer Carry-In or Mail-In Service**

You will deliver or mail as IBM specifies (prepaid unless IBM specifies otherwise) the failing Machine suitably packaged to a location IBM designates. After IBM has repaired or exchanged the Machine, IBM will make it available for your collection or, for Mail-in Service, IBM will return it to you at IBM's expense, unless IBM specifies otherwise. You are responsible for the subsequent installation and verification of the Machine.

### 5. **CRU and On-site Service**

This type of Warranty Service is a combination of Type 1 and Type 2 (see above).

### 6. **CRU and Courier or Depot Service**

This type of Warranty Service is a combination of Type 1 and Type 3 (see above).

### 7. **CRU and Customer Carry-In or Mail-In Service**

This type of Warranty Service is a combination of Type 1 and Type 4 (see above).

**When a 5, 6 or 7 type of warranty service is listed, IBM will determine which type of warranty service is appropriate for the repair.**

\* This type of service is called ThinkPad EasyServ or EasyServ in some countries. The IBM Machine Warranty worldwide web site at [http://www.ibm.com/servers/support/machine\\_warranties/](http://www.ibm.com/servers/support/machine_warranties/) provides a worldwide overview of IBM's Limited Warranty for Machines, a Glossary of IBM definitions, Frequently Asked Questions (FAQs) and Support by Product (Machine) with links to Product Support pages. **The IBM Statement of Limited Warranty is also available on this site in 29 languages.**

To obtain warranty service contact IBM or your IBM reseller. In Canada or the United States, call 1-800-IBM-SERV (426-7378). In Canada or the United States, call 1-800-IBM-SERV (426-7378). For other countries, see the telephone numbers below.

Phone numbers are subject to change without notice. For the latest phone number list, go to <http://www.ibm.com/pc/support> and click **Support Phone List**.

Country or Region	Telephone Number	Country or Region	Telephone Number
Africa	+44 (0) 1475 555 055	Japan	Desktop: 0120-887-870 <ul style="list-style-type: none"> <li>• Overseas calls: 81-46-266-1084</li> </ul> ThinkPad: 0120-887-874 <ul style="list-style-type: none"> <li>• Overseas calls: 81-46-266-1084</li> </ul> IntelliStation and xSeries: 81-46-266-1358  PC Software: 0120-558-695 <ul style="list-style-type: none"> <li>• Overseas calls: 81-44-200-8666</li> </ul>
Argentina	0800-666-0011	Luxembourg	298-977-5063

<b>Australia</b>	<b>131-426</b>	<b>Malaysia</b>	<b>(60) 3-7727-7800</b>
<b>Austria</b>	<b>01-24592-5901</b>	<b>Mexico</b>	<b>001-866-434-2080</b>
<b>Belgium</b>	<b>Dutch: 02-210 9820</b> <b>French: 02-210 9800</b>	<b>Netherlands</b>	<b>020-514 5770</b>
Brazil	55-11-3889-8986	New Zealand	0800-446-149
Canada	English: 1-800-565-3344 French: 1-800-565-3344 In Toronto: 416-383-3344	Nicaragua	255-6658
Chile	800-224-488	Norway	66 81 11 00
China	800-810-1818	Panama	206-6047
China (Hong Kong and S.A.R.)	Home PC: 852-2825-7799 Commercial PC: 852-8205-0333	Peru	0-800-50-866
Colombia	980-912-3021	Philippines	(63) 2-995-2225
Costa Rica	284-3911	Portugal	21-892-7147
Denmark	45 20 82 00	Russia	095-940-2000
Dominican Republic	566-4755 or 566-5161 ext. 8201 Toll Free within the Dominican Republic: 1-200-1929	Singapore	(65) 1-800-840-9911
Ecuador	1-800-426911 (option #4)	Spain	91-714-7983
El Salvador	250-5696	Sweden	08-477 4420
Finland	09-459 69 60	Switzerland	058-333-0900
France	02 38 55 74 50	Taiwan	886-2-8723-9799
Germany	07032-1549 201	Thailand	(66) 2-273-4000

<b>Guatemala</b>	<b>335-8490</b>	<b>Turkey</b>	<b>00-800-446-32-041</b>
Honduras	Tegucigalpa & Sand Pedro Sula: 232-4222  San Pedro Sula: 552-2234	United Kingdom	0-1475-555 055
India	1600-44-6666	United States	1-800-IBM-SERV  (1-800-426-7378)
Indonesia	(62) 21-523-8535	Uruguay	000-411-005-6649
Ireland	01-815-9202	Venezuela	0-800-100-2011
Italy	02-7031-6101	Vietnam	Ho Chi Minh: (84) 8-829-5160  Hanoi: (84) 4-843-6675



---

## 附錄 D. Guarantee supplement for Mexico

This supplement is considered part of IBM's Statement of Limited Warranty and shall be effective solely and exclusively for products distributed and commercialized within Territory of the Mexican United States. In the event of a conflict, the terms of this supplement shall apply.

All software programs pre-loaded in the equipment shall only have a thirty- (30) day guarantee for installation defects from the date of purchase. IBM is not responsible for the information in such software programs and/or any additional software programs installed by you or installed after purchase of the product.

Services not chargeable to the guarantee shall be charged to the final user, prior an authorization.

In the event that warranty repair is required please call the IBM Support Center at 001-866-434-2080, where you will be directed to the nearest Authorized Service Center. Should no Authorized Service Center exist in your city, location or within 70 kilometers of your city or location, the guarantee includes any reasonable delivery charges related to the transportation of the product to our nearest Authorized Service Center. Please call the nearest Authorized Service Center to obtain the necessary approvals or information concerning the shipment of the product and the shipment address.

To obtain a list of Authorized Service Centers, please visit:  
[http://www.pc.ibm.com/la/centros\\_de\\_servicio/servicio\\_mexico/servicio\\_mexico.html](http://www.pc.ibm.com/la/centros_de_servicio/servicio_mexico/servicio_mexico.html)

**Manufactured by:**

**SCI Systems de México, S.A. de C.V.  
Av. De la Solidaridad Iberoamericana No. 7020  
Col. Club de Golf Atlas  
El Salto, Jalisco, México  
C.P. 45680,  
Tel. 01-800-3676900**

**Marketing by:**

**IBM de México, Comercialización y  
Servicios, S. A. de C. V.  
Alfonso Nápoles Gándara No 3111  
Parque Corporativo de Peña Blanca  
Delegación Álvaro Obregón  
México, D.F., México  
C.P. 01210,  
Tel. 01-800-00-325-00**





---

## 附錄 E. Notices

IBM may not offer the products, services, or features discussed in this document in all countries. Consult your local IBM representative for information on the products and services currently available in your area. Any reference to an IBM product, program, or service is not intended to state or imply that only that IBM product, program, or service may be used. Any functionally equivalent product, program, or service that does not infringe any IBM intellectual property right may be used instead. However, it is the user's responsibility to evaluate and verify the operation of any non-IBM product, program, or service.

IBM may have patents or pending patent applications covering subject matter described in this document. The furnishing of this document does not give you any license to these patents. You can send license inquiries, in writing, to:

*IBM Director of Licensing  
IBM Corporation  
North Castle Drive  
Armonk, NY 10504-1785  
U.S.A.*

INTERNATIONAL BUSINESS MACHINES CORPORATION PROVIDES THIS PUBLICATION 『AS IS』 WITHOUT WARRANTY OF ANY KIND, EITHER EXPRESS OR IMPLIED, INCLUDING, BUT NOT LIMITED TO, THE IMPLIED WARRANTIES OF NON-INFRINGEMENT, MERCHANTABILITY OR FITNESS FOR A PARTICULAR PURPOSE. Some jurisdictions do not allow disclaimer of express or implied warranties in certain transactions, therefore, this statement may not apply to you.

This information could include technical inaccuracies or typographical errors. Changes are periodically made to the information herein; these changes will be incorporated in new editions of the publication. IBM may make improvements and/or changes in the product(s) and/or the program(s) described in this publication at any time without notice.

The products described in this document are not intended for use in implantation or other life support applications where malfunction may result in injury or death to persons. The information contained in this document does not affect or change IBM product specifications or warranties. Nothing in this document shall operate as an express or implied license or indemnity under the intellectual property rights of IBM or third parties. All information contained in this document was obtained in specific environments and is presented as an illustration. The result obtained in other operating environments may vary.

IBM may use or distribute any of the information you supply in any way it believes appropriate without incurring any obligation to you.

Any references in this publication to non-IBM Web sites are provided for convenience only and do not in any manner serve as an endorsement of those Web sites. The materials at those Web sites are not part of the materials for this IBM product, and use of those Web sites is at your own risk.

Any performance data contained herein was determined in a controlled environment. Therefore, the result obtained in other operating environments may vary significantly. Some measurements may have been made on development-level systems and there is no guarantee that these measurements will be the same on generally available systems. Furthermore, some measurements may have been estimated through extrapolation. Actual results may vary. Users of this document should verify the applicable data for their specific environment.

---

## Trademarks

The following terms are trademarks of International Business Machines Corporation in the United States, other countries, or both:

IBM  
IBM logo  
ThinkPad  
Ultrabay

Microsoft and Windows are trademarks of Microsoft Corporation in the United States, other countries, or both.

Other company, product, or service names may be trademarks or service marks of others.

---

## Electronic emission notices

IBM ThinkPad Multi-Burner Plus Ultrabay Enhanced Drive

---

## Federal Communications Commission (FCC) statement

**Note:** This equipment has been tested and found to comply with the limits for a Class B digital device, pursuant to Part 15 of the FCC Rules. These limits are designed to provide reasonable protection against harmful interference in a residential installation. This equipment generates, uses, and can radiate radio frequency energy and, if not installed and used in accordance with the instructions, may cause harmful interference to radio communications. However, there is no guarantee that interference will not occur in a particular installation. If this equipment does cause harmful interference to radio or television reception, which can be determined by turning the equipment off and on, the user is encouraged to try to correct the interference by one or more of the following measures:

- Reorient or relocate the receiving antenna.
- Increase the separation between the equipment and receiver.
- Connect the equipment into an outlet on a circuit different from that to which the receiver is connected.
- Consult an IBM authorized dealer or service representative for help.

Properly shielded and grounded cables and connectors must be used in order to meet FCC emission limits. Proper cables and connectors are available from IBM authorized dealers. IBM is not responsible for any radio or television interference caused by using other than recommended cables and connectors or by unauthorized changes or modifications to this equipment. Unauthorized changes or modifications could void the user's authority to operate the equipment.

This device complies with Part 15 of the FCC Rules. Operation is subject to the following two conditions: (1) this device may not cause harmful interference, and (2) this device must accept any interference received, including interference that may cause undesired operation.

Responsible party:

International Business Machines Corporation  
New Orchard Road  
Armonk, NY 10504  
Telephone: 1-919-543-2193



Tested To Comply  
With FCC Standards

FOR HOME OR OFFICE USE

### **Industry Canada Class B emission compliance statement**

This Class B digital apparatus complies with Canadian ICES-003.

### **Avis de conformite a la reglementation d'Industrie Canada**

Cet appareil numérique de la classe B est conforme à la norme NMB-003 du Canada.

### **Deutsche EMV-Direktive (electromagnetische Verträglichkeit)**

Zulassungsbeseinigunglaut dem Deutschen Gesetz über die elektromagnetische Verträglichkeit von Geräten (EMVG) vom 30. August 1995 (bzw. der EMC EG Richtlinie 89/336):

Dieses Gerät ist berechtigt in Übereinstimmungmit dem Deutschen EMVG das EG-Konformitätszeichen - CE - zu führen. Verantwortlich für die Konformitätserklärung nach Paragraph 5 des EMVG ist die:

IBM Deutschland Informationssysteme GmbH, 70548 Stuttgart.

Informationen in Hinsicht EMVG Paragraph 3 Abs. (2) 2:

Das Gerät erfüllt die Schutzanforderungen nach EN 55024:1998 und EN 55022:1998 Klasse B.
--

EN 55022 Hinweis:

『Wird dieses Gerät in einer industriellen Umgebung betrieben (wie in EN 55022:B festgelegt), dann kann es dabei eventuell gestört werden. In solch einem FA11 ist der Abstand bzw. die Abschirmungzu der industriellen Störquelle zu vergrößern.』

Anmerkung:

Um die Einhaltung des EMVG sicherzustellen sind die Geräte, wie in den IBM Handbüchern angegeben, zu installieren und zu betreiben.

### **European Union - emission directive**

This product is in conformity with the protection requirements of EU Council Directive 89/336/ECC on the approximation of the laws of the Member States relating to electromagnetic compatibility.

IBM can not accept responsibility for any failure to satisfy the protection requirements resulting from a non-recommended modification of the product, including the fitting of non-IBM option cards.

This product has been tested and found to comply with the limits for Class B Information Technology Equipment according to European Standard EN 55022. The limits for Class B equipment were derived for typical residential environments to provide reasonable protection against interference with licensed communication devices.

### **Union Européenne - Directive Conformité électromagnétique**

Ce produit est conforme aux exigences de protection de la Directive 89/336/EEC du Conseil de l'UE sur le rapprochement des lois des États membres en matière de compatibilité électromagnétique.

IBM ne peut accepter aucune responsabilité pour le manquement aux exigences de protection résultant d'une modification non recommandée du produit, y compris l'installation de cartes autres que les cartes IBM.

Ce produit a été testé et il satisfait les conditions de l'équipement informatique de Classe B en vertu de Standard européen EN 55022. Les conditions pour l'équipement de Classe B ont été définies en fonction d'un contexte résidentiel ordinaire afin de fournir une protection raisonnable contre l'interférence d'appareils de communication autorisés.

### **Unione Europea - Directiva EMC (Conformidad electromagnética)**

Este producto satisface los requisitos de protección del Consejo de la UE, Directiva 89/336/CEE en lo que a la legislatura de los Estados Miembros sobre compatibilidad electromagnética se refiere.

IBM no puede aceptar responsabilidad alguna si este producto deja de satisfacer dichos requisitos de protección como resultado de una modificación no recomendada del producto, incluyendo el ajuste de tarjetas de opción que no sean IBM.

Este producto ha sido probado y satisface los límites para Equipos Informáticos Clase B de conformidad con el Estándar Europeo EN 55022. Los límites para los equipos de Clase B se han establecido para entornos residenciales típicos a fin de proporcionar una protección razonable contra las interferencias con dispositivos de comunicación licenciados.

### **Unione Europea - Normativa EMC**

Questo prodotto è conforme alle normative di protezione ai sensi della Direttiva del Consiglio dell'Unione Europea 89/336/CEE sull'armonizzazione legislativa degli stati membri in materia di compatibilità elettromagnetica.

IBM non accetta responsabilità alcuna per la mancata conformità alle normative di protezione dovuta a modifiche non consigliate al prodotto, compresa l'installazione di schede e componenti di marca diversa da IBM.

Le prove effettuate sul presente prodotto hanno accertato che esso rientra nei limiti stabiliti per le apparecchiature di informatica Classe B ai sensi della Norma Europea EN 55022. I limiti delle apparecchiature della Classe B sono stati stabiliti al fine di fornire ragionevole protezione da interferenze mediante dispositivi di comunicazione in concessione in ambienti residenziali tipici.

이 기기는 가정용으로 전자파 적합등록을 한 기기로서  
주거지역에서는 물론 모든 지역에서 사용할 수 있습니다.

この装置は、情報処理装置等電波障害自主規制協議会（VCCI）の基準に基づくクラスB情報技術装置です。この装置は、家庭環境で使用することを目的としていますが、この装置がラジオやテレビジョン受信機に近接して使用されると、受信障害を引き起こすことがあります。  
取扱説明書に従って正しい取り扱いをして下さい。

**Japanese statement of compliance for products less than or equal to 20 A per phase**

**高調波ガイドライン適合品**



Part Number: 73P3315

Printed in Taiwan

(1P) P/N: 73P3315

