

MODEL TC-131 TAPE CONTROLLER  
LOGIC MANUAL



7

MODEL TC-131 TAPE CONTROLLER  
LOGIC MANUAL

PUBLICATION NUMBER

91000489 A

**western peripherals**

14321 MYFORD ROAD  
TUSTIN, CALIFORNIA 92680

© 1981 by Western Peripherals, Inc.  
All Rights Reserved

## TABLE OF CONTENTS

TITLE	DRAWING NO.
Fabrication Drawing, PWB Grant Continuity	131009
Assembly, TC-131 Tape Controller	60000601
Assembly Drawing, TC131N Tape Controller	60000692
Assembly Drawing, TC131 Tape Controller	60000841
Schematic, TC-131 Tape Controller	75000539
Schematic, TC-131 Tape Controller	75000752
Modification Drawing, TC131 Configuration "A"	79000683
Modification Drawing, TC131N Configuration "A"	79000709
Prom Set, TC131, NRZ	18001313
Prom Set, TC131/151, PE	18001321
Parts List, TC-131 Tape Controller	60000601
Appendix A	Cables and Adapters
Notes	

## HOW TO USE LOGIC MANUALS

### Logic Manuals Contain:

- Schematics of all boards (for logic troubleshooting).
- Assembly drawings (for assembly identification and parts locating).
- Some manuals also contain: Special modifications, block diagrams, flowcharts, listings and other reference information.

### Arrangement of Drawings:

- Drawings are generally arranged in numerical order except where other arrangements provide greater convenience.  
(See Table of Contents)

### Table of Contents:

- Provides a listing of the drawings as they appear in the manual.

### Functional Index (when used):

- Provides lists of drawings, grouping them as they are used in the system.
- Drawing numbers facilitate easy look-up (See Table of Contents).

### Thumb Tabs (when used):

- Provides ready access to schematics.

### ●NOTICE:

CHECK AT THE REAR OF THIS MANUAL FOR:

- Latest Drawing Changes
- Added Drawings
- Notes and Additional Information



## HOW TO USE SCHEMATICS

### Reference Numbering

\*Circled numbers in the lower right-hand corner are used as page numbers for the schematic.

(Drawing sheet numbers may be disregarded)

\*Signal sources and destinations are referenced to these page numbers. Example:

Source (from page 3): 3 - READ  
Destination (to page 4 & 5): START - 4, 5

### Block Diagrams

\*Most block diagrams provide page reference numbers in each block which identify the schematic page where the logic may be found.

### Signal Levels

\*Normally signals are true when high (+5V) and false when low (0V).

\*Signals with bars (WRITE) are true when low and false when high.

### Off-Board Connectors

\*Small boxes or diamonds are used to identify signals which exit the board. (Where the numbers are in the format BA2, CV1, DR2, etc. The first letter identifies the connector, The second digit identifies the pin of the connector, and the third digit identifies the side of the board where side one is the component side and side two is the solder side).



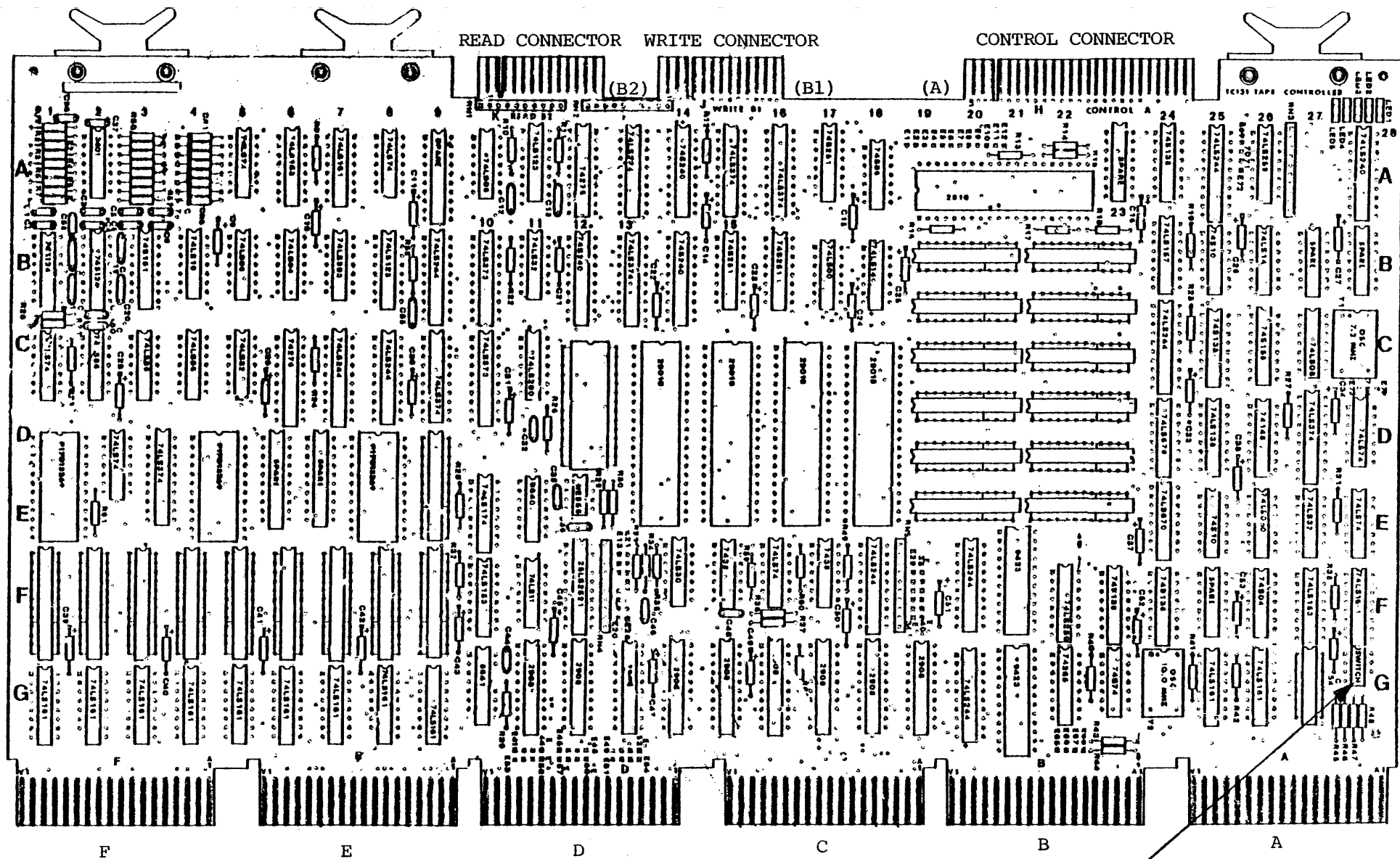

READ CONNECTOR WRITE CONNECTOR

CONTROL CONNECTOR

(B2)

(B1)

(A)

TC131 TAPE CONTROLLER

SPC/MUD BACKPLANE CONNECTORS

SPEED SELECTION SWITCHES

TC-131 TAPE CONTROLLER

6000601

The "NRZI-ONLY" Version of the Controller  
is the same as Assy. 60000601 with parts  
deleted as noted on Schematic 75000539.

TC-131N Tape Controller  
60000692

NOTES: UNLESS OTHERWISE SPECIFIED

1. FOR MATERIAL SEE B/M 60000841
- ② MARK WITH ASSY NO AND LATEST REV LTR.  
APPROX. WHERE SHOWN
- 3 MAX. HEIGHT OF COMPONENTS FROM SURFACE  
OF BOARD NOT TO EXCEED .400.
- 4 REF SCHEMATIC 75000752
- ⑤ ON CIRCUIT BOARD ZONE B7- RESISTOR  
R66 HAS BEEN SCREENED INCORRECTLY  
IS R66 (NOT R65).

 <b>western peripherals</b> ANAHEIM, CALIFORNIA		
ASSEMBLY DRAWING TC 131 TAPE CONTROLLER		
SIZE	CODE IDENT NO.	DRAWING NO.
<b>D</b>		60000841
SCALE FULL		SHEET 1 OF 4



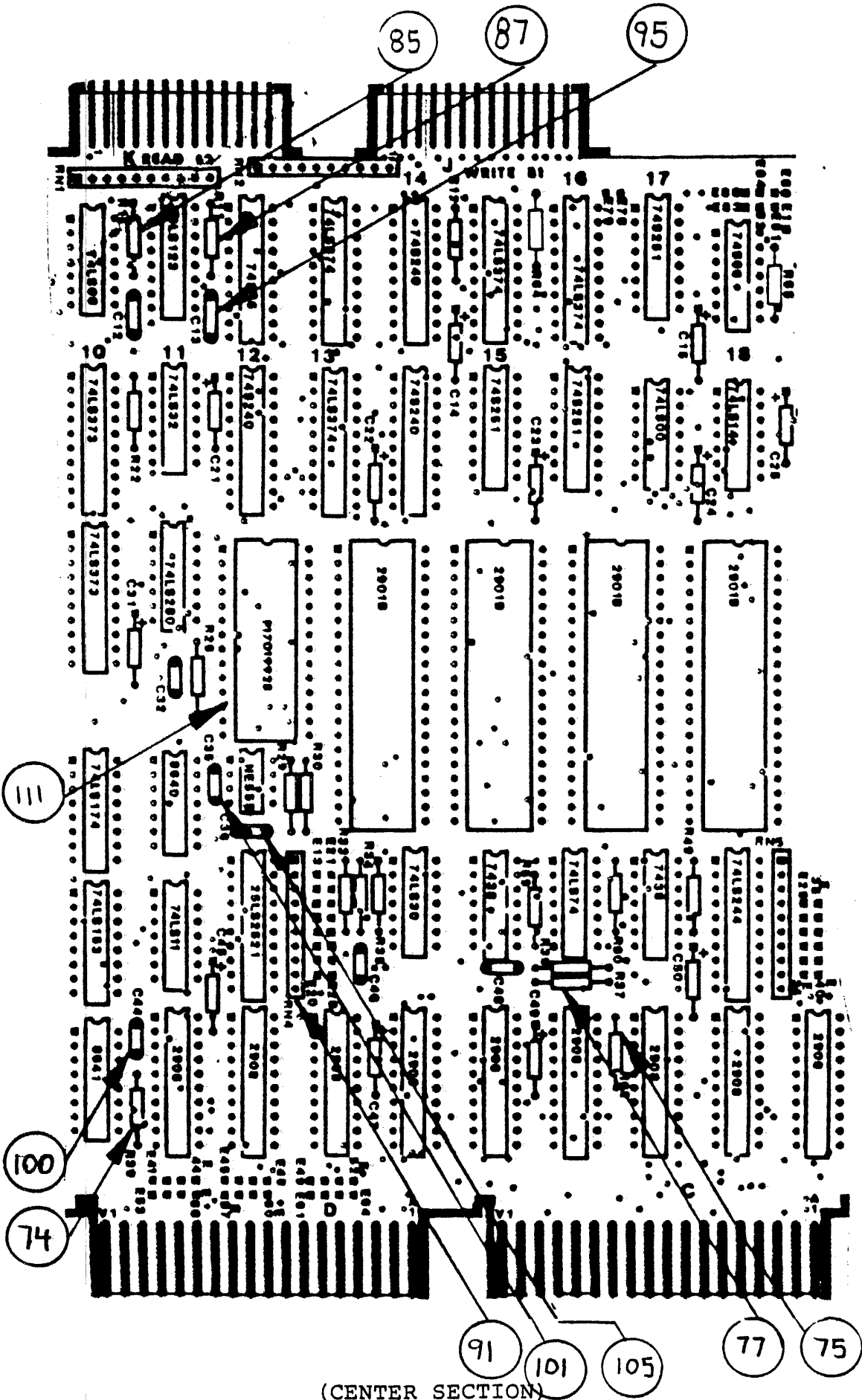

(CENTER SECTION)

60000841

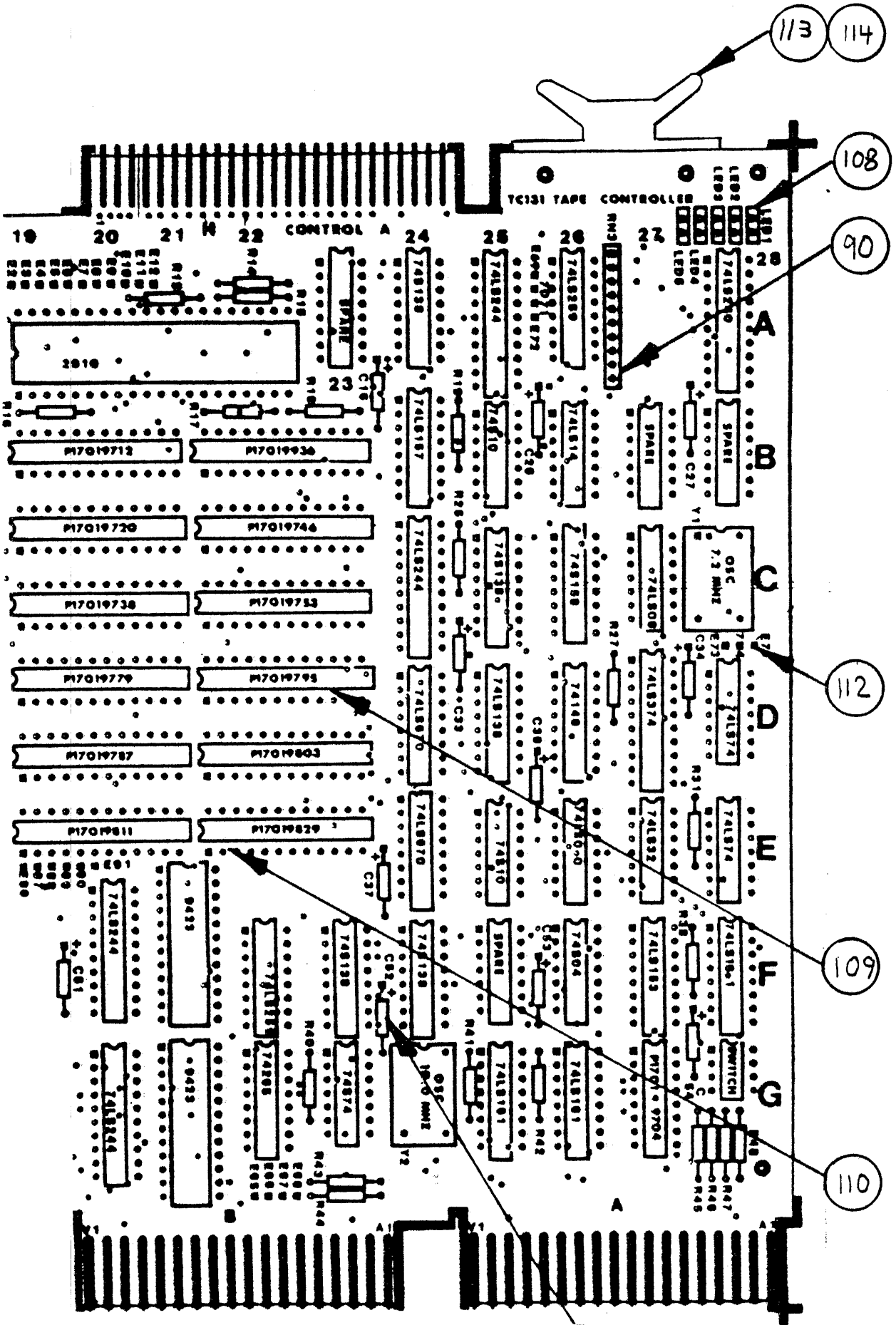

(RIGHT SECTION)

6000841



# CALL-OUT NOTES

- 2 PLCS (74)  
R18, R39
- 3 PLCS (76)  
R14, R15, R20
- 3 PLCS (78)  
R29, R30, R21
- 20 PLCS (79)  
R9, R12, R13, R16, R17,  
R19, R22, R24, R25, R27,  
R28, R31, R32, R33, R38,  
R40-R43, R41
- 10 PLCS (80)  
R5, R7, R8, R23, R44-R48  
R64
- 3 PLCS (81)  
R1, R2, R4
- 2 PLCS (80)  
R50, R51
- (89)  
R63
- (93)  
C17
- (94)  
C18
- (96)  
C20
- (98)  
2 PLCS  
C1, C6
- (99)  
C4
- (100)  
4 PLCS  
C32, C44, C46, C48
- (102)  
C2
- (104)  
C3
- (105)  
7 PLCS  
R26, R34, R36, R49,  
R59, R60, R62
- (77) 2 PLCS  
R35, R37
- (82) R57
- (83) 2 PLCS  
R54, R55
- (84) R52
- (85) 2 PLCS  
R10, R58
- (87) R11
- (88) 4 PLCS  
R3, R6, R53, R56
- (90) 3 PLCS  
RN1, RN2, RN3
- (91) 2 PLCS  
RN4, RN5
- (92) 8 PLCS  
CR1-CR8
- (95) 4 PLCS  
C12, C13, C19, C55
- (97) C7
- (101) C35
- (103) 2 PLCS  
C5, C8
- (105) 6 PLCS  
C36, C56-C60
- (106) 34 PLCS  
C9, C10, C11, C14, C15, C16, C21-C31,  
C33, C34, C37-C43, C45, C47, C49-C54.
- (108) 5 PLCS  
LED1-LED5
- (109) 22 PLCS  
B19, B21, C19A, C19B, C21A, C21B,  
D9, D19A, D19B, D21A, D21B,  
E19, E21, F1-F9.
- (110) 23 PLCS  
B19, B21, C19A, C19B, C21A, C21B,  
D9, D19A, D19B, D21A, D21B, E19,  
E21, F1-F9, G27
- (112) 75 PLCS  
E1-E75
- (113) 3 PLCS
- (114) 6 PLCS
- (120)
- (5)
- (121) R66

TABLE OF CONTENTS

TC-131 SCHEMATIC

<u>CPU BUS</u>	<u>PAGE</u>
CPU Address and Data Bus Transceivers	1
TM-11 Address Detector	2
Bus Request/Grant Logic	
CPU Vector Jumpers and Gate	
PLA Bus Sequencer	3
NXM Timer/Latch	
Bus Control Transceiver	
Reset Logic	4
Bus-Master Control	
<u>DATA PROCESSOR</u>	
2901 Data Processor	5
Write Byte Control	
Literal Gate	6
Control Pulse Decoder	
Destination Decoder	
Source Decoder	
Indicator LED's	
"A" Latch	
"B" Latch	
<u>ADDRESS PROCESSOR</u>	
Condition Test Registers	7
Condition Test Select	
D-Bus Test Select	
Micro-Interrupt Vector RAM's	

TABLE OF CONTENTS (CONTINUED)

<u>TITLE</u>	<u>PAGE</u>
Micro-Interrupt Control	8
2910 Instruction Multiplexer	9
2910 Program Address Processor	
PIO Vector Gate	
Timer Bit Generator	10
Controller Clock Generator	
Data Buffer FIFO (P/O Data Processor)	
Control Store ROM's (0-511)	11
Control Store ROM's (512-1023)	12
<u>TAPE INTERFACE</u>	
Tape Write Clock Generator	13
Tape Unit Command Register & Driver	14
Unit Select Decoder & Driver	
Write Data Register & Driver	
Tape Status Terminator & Gate	15
Tape Unit Select Register	
Parity Generator & Control	
NRZI Read Register	16
Tape Control & Status	
Read Strobe Interrupt	
<u>PE READ LOGIC</u>	
PE Deskew Buffer Timer	16

TABLE OF CONTENTS (CONTINUED)

<u>TITLE</u>	<u>PAGE</u>
PE Data Gate	17
PE Drop-Out Gate	
PE Parity Control & Gate	
PE Status RDM	
PE Status Latch	
PE Reference Divider	18
PE Phase Comparator	
PE Read Activity Detector and Control	
PE Voltage Controlled Oscillators	19
PE Clock Selector	
PE Read Register	20-22
PE Window Counter	
PE Desken Register	
PE Sequencer ROM's	23-25

	A	B	C	D	E	F	G
1		19	19	20		23	20
2	19	19	20,21	20		23	20
3		19	21,22	20,22		23	20
4		16	18,22	21		24	21
5	18	16,17	17,18	21		24	21
6	18	6,18	18			24	21
7	18	18	17	22		25	22
8	18	16	17			25	22
9		17	17	17		25	22
10	3,4	16	16		15	15	3
11	3,4	3,7	15		4	3	1
12	3,16	16	3		10	2	1
13	14	14	5				1
14	14	14				2	1
15	7	7	5			2,4	2
16	7	7	5			2,4	1
17	7	7				4	1
18	7	3,7	5			2	1
19	9	11	A/B 11	A/B 11	11		1
20						6	6
21		11	A/B 12	A/B 12	12	10	10
22						6	10
23						6	10
24	14	9	9	7	7	6	
25	14	6	6	8	5,7		13
26	6	5,6,8	5	8	4,8,13	13	13
27			5,10	8	5,8	13	13
28	15			8	8	13	13

TC-131  
 BOARD LOCATION  
 TO  
 SCHEMATIC PAGE  
 CROSS-REFERENCE  
 (ASSY 60000601)

REVISIONS

LTR	DESCRIPTION	DATE	APPROVED
A	RELEASE	1-19-81	<i>[Signature]</i>
B	REVISED SMTS ③ & ④ PER ECO 852	1-28-81	<i>[Signature]</i>
C	REF. E.C.O. 854	2-26-81	<i>[Signature]</i>

CONTROL A

	H	
SLT 6	1 2	GND
SLT 7	3 4	GND
SLT 5	5 6	GND
SLT 4	7 8	GND
SLT 3	9 10	GND
SLT 0	11 12	GND
SLT 1	13 14	GND
SLT 2	15 16	GND
FLPT	17 18	GND
WNB	19 20	GND
QVW	21 22	GND
RSL	23 24	GND
EOTP	25 26	GND
RWC	27 28	GND
DSL	29 30	GND
B0TP	31 32	GND
FSL	33 34	GND
+5V	35 36	GND
+5V	37 38	GND
RWG	39 40	GND
TRDY	41 42	GND
ONL	43 44	GND
	45 46	GND
SPD	47 48	GND
NRZ	49 50	GND

WRITE B1

	J	
WDS	1 2	GND
WD7	3 4	GND
WARS	5 6	GND
WDS	7 8	GND
	9 10	GND
WDS	11 12	GND
WDP	13 14	GND
WD4	15 16	GND
WDO	17 18	GND
WD3	19 20	GND
WD1	21 22	GND
WD2	23 24	GND
+5V	25 26	GND

READ B2

	K	
RD7	1 2	GND
RD6	3 4	GND
RD5	5 6	GND
RD4	7 8	GND
RD3	9 10	GND
RD2	11 12	GND
RD1	13 14	GND
NRZ	15 16	GND
	17 18	GND
RD0	19 20	GND
RDS	21 22	GND
RDP	23 24	GND
	25 26	GND

⑦ SPEED SETTING

SW POS	125	125	125	125	75	75	75	45	45	37.5	SELB
628	75	45	37.5	25	45	37.5	25	37.5	25	25	SELA
1	C	C	C	C	C	C	C	O	O	O	
2	C	C	C	C	O	O	O	C	C	O	
3	C	C	O	O	C	O	O	C	O	C	
4	C	O	C	O	O	C	O	O	C	C	

C = ON  
O = OFF

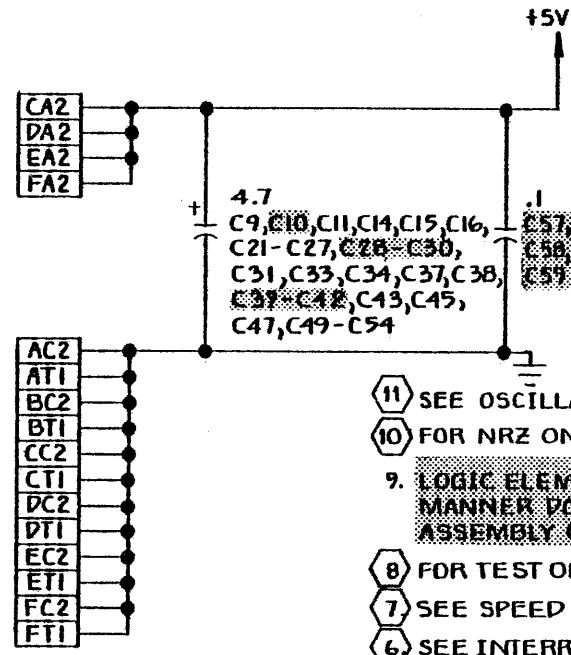

LAST DESIGNATION USED	
RESISTOR	R63
CAPACITOR	C60
DIODE	CR8
OSCILLATOR	Y2
LIGHT EMITTING DIODE	LED 5
RESISTOR NETWORK	RN5

- ⑪ SEE OSCILLATOR JUMPER TABLE.
  - ⑩ FOR NRZ ONLY OPERATION.
  - 9. LOGIC ELEMENTS SHADED IN THIS MANNER DO NOT EXIST ON THE TC 131N ASSEMBLY 60000692 (NRZ ONLY).
  - ⑧ FOR TEST ONLY
  - ⑦ SEE SPEED SETTING TABLE.
  - ⑥ SEE INTERRUPT PRIORITY LEVEL TABLE.
  - ⑤ SEE INTERRUPT VECTOR TABLE.
  - ④ SEE DEVICE ADDRESS TABLE
  - 3. REFERENCE ASSY 60000601.
  - 2. CAPACITOR VALUES ARE IN MICROFARADS.
  - 1. RESISTANCE VALUES ARE IN OHMS.
- NOTES: UNLESS OTHERWISE SPECIFIED

TOLERANCES UNLESS OTHERWISE SPECIFIED FRACTIONS DEC. ANGLES		western peripherals™ TUSTIN, CALIFORNIA		
±	±			SCHEMATIC TC-131 TAPE CONTROLLER
APPROVALS	DATE	SCALE	SIZE	DRAWING NO.
DRAWN L. FRANZKE	10-28-80			
CHECKED HDKOGA	11-10-80	DO NOT SCALE DRAWING		SHEET 1 OF 27

REVISIONS			
LTR	DESCRIPTION	DATE	APPROVED

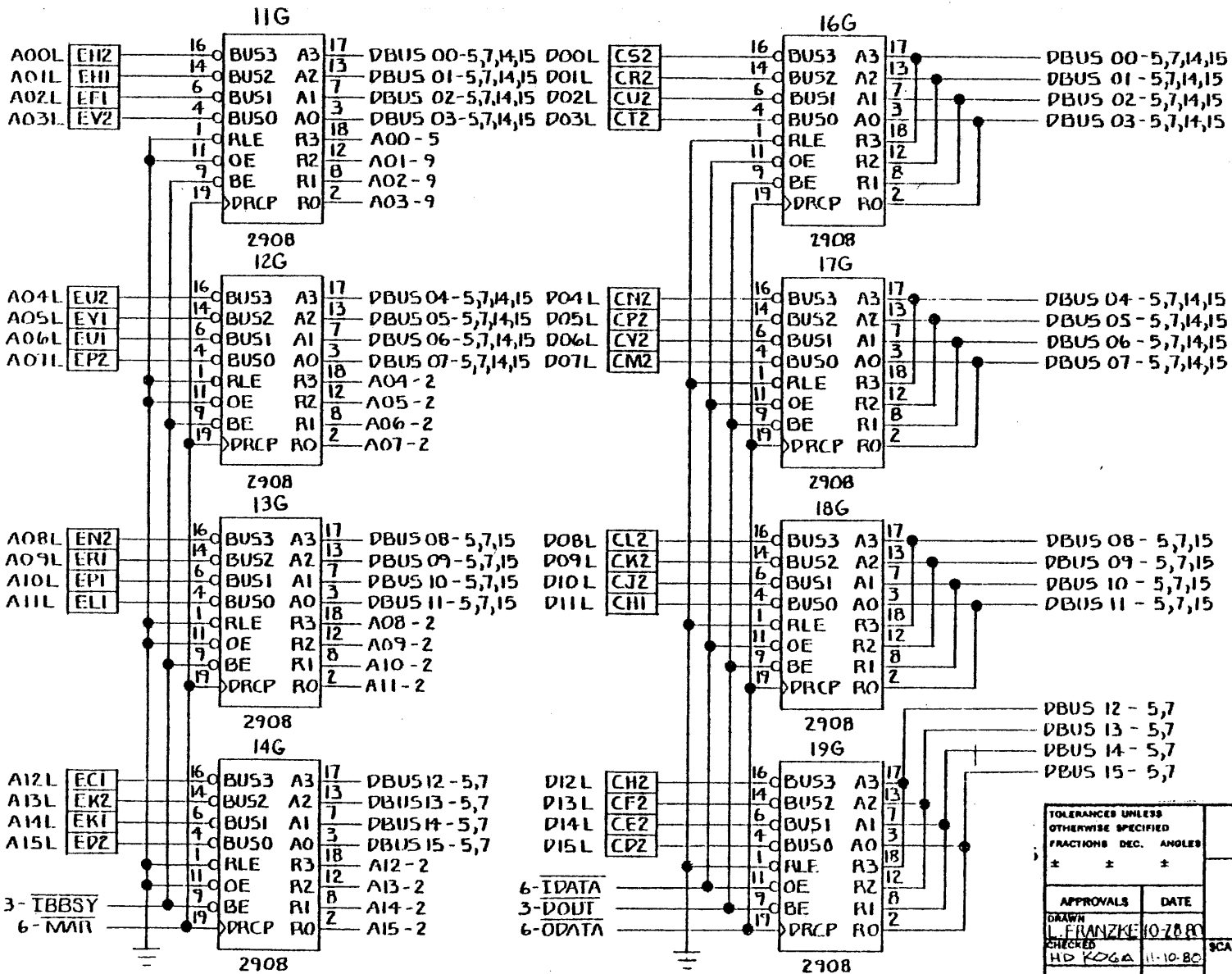

TOLERANCES UNLESS OTHERWISE SPECIFIED  
FRACTIONS DEC. ANGLES  
± ± ±



PDP-11 ADDRESS AND DATA BUS XCVRS

APPROVALS	DATE
DRAWN L. FRANZKE	10-28-80
CHECKED HD KOGA	11-10-80

SCALE	SIZE	DRAWING NO.
	B	75000539

DO NOT SCALE DRAWING SHEET 2 OF 27

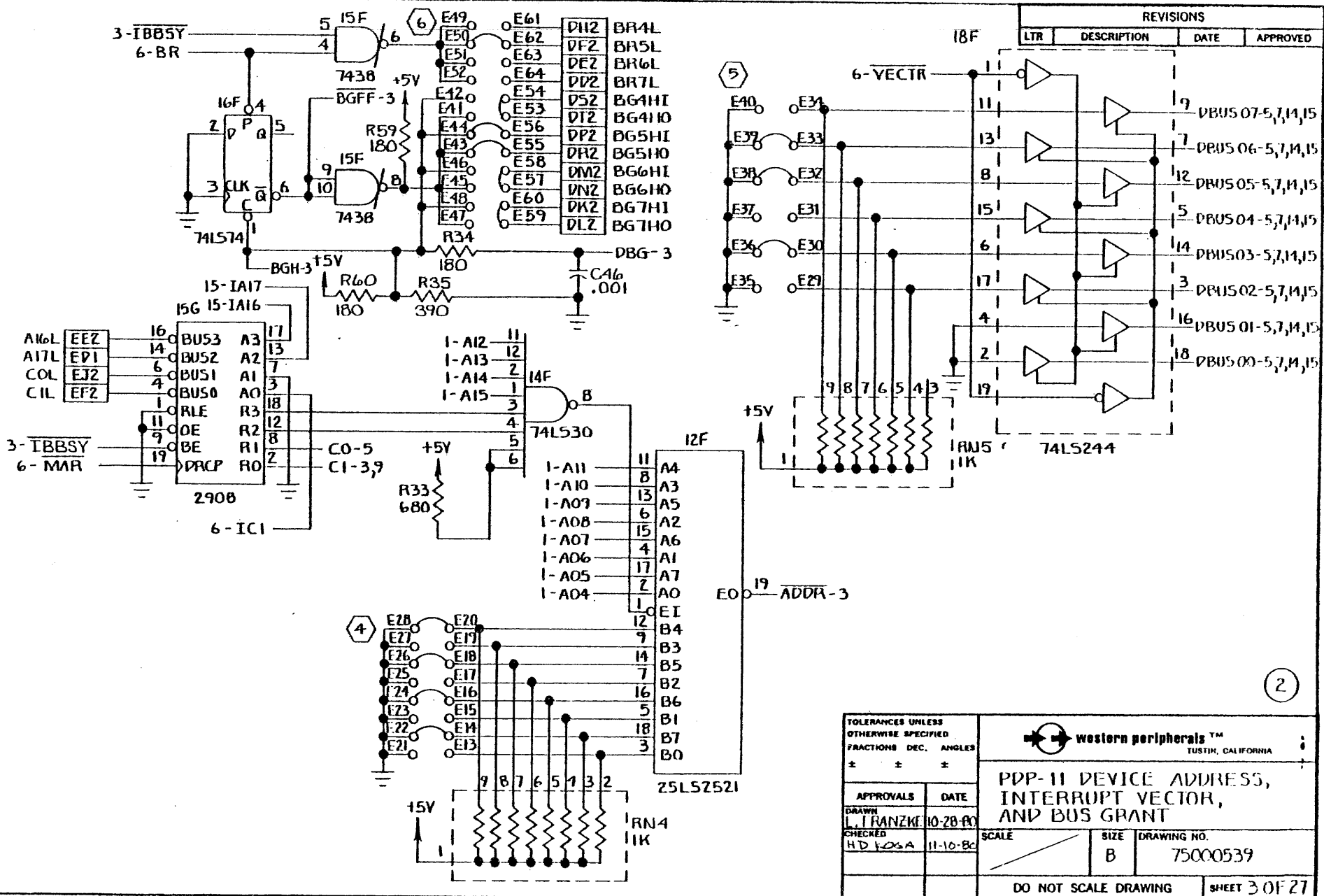

REVISIONS			
LTR	DESCRIPTION	DATE	APPROVED
17	DBUS 07-5,7,11,15		
7	DBUS 06-5,7,11,15		
12	DBUS 05-5,7,11,15		
5	DBUS 04-5,7,11,15		
14	DBUS 03-5,7,11,15		
3	DBUS 02-5,7,11,15		
16	DBUS 01-5,7,11,15		
18	DBUS 00-5,7,11,15		

(2)

TOLERANCES UNLESS OTHERWISE SPECIFIED FRACTIONS DEC. ANGLES ± ± ±		 <b>western peripherals™</b> TUSTIN, CALIFORNIA	
APPROVALS DRAWN: L. I. RANZKE CHECKED: HD KOGA		DATE: 10-20-80 11-10-80	
PDP-11 DEVICE ADDRESS, INTERRUPT VECTOR, AND BUS GRANT		SCALE: /	SIZE: B DRAWING NO.: 75000539
DO NOT SCALE DRAWING			SHEET 3 OF 27



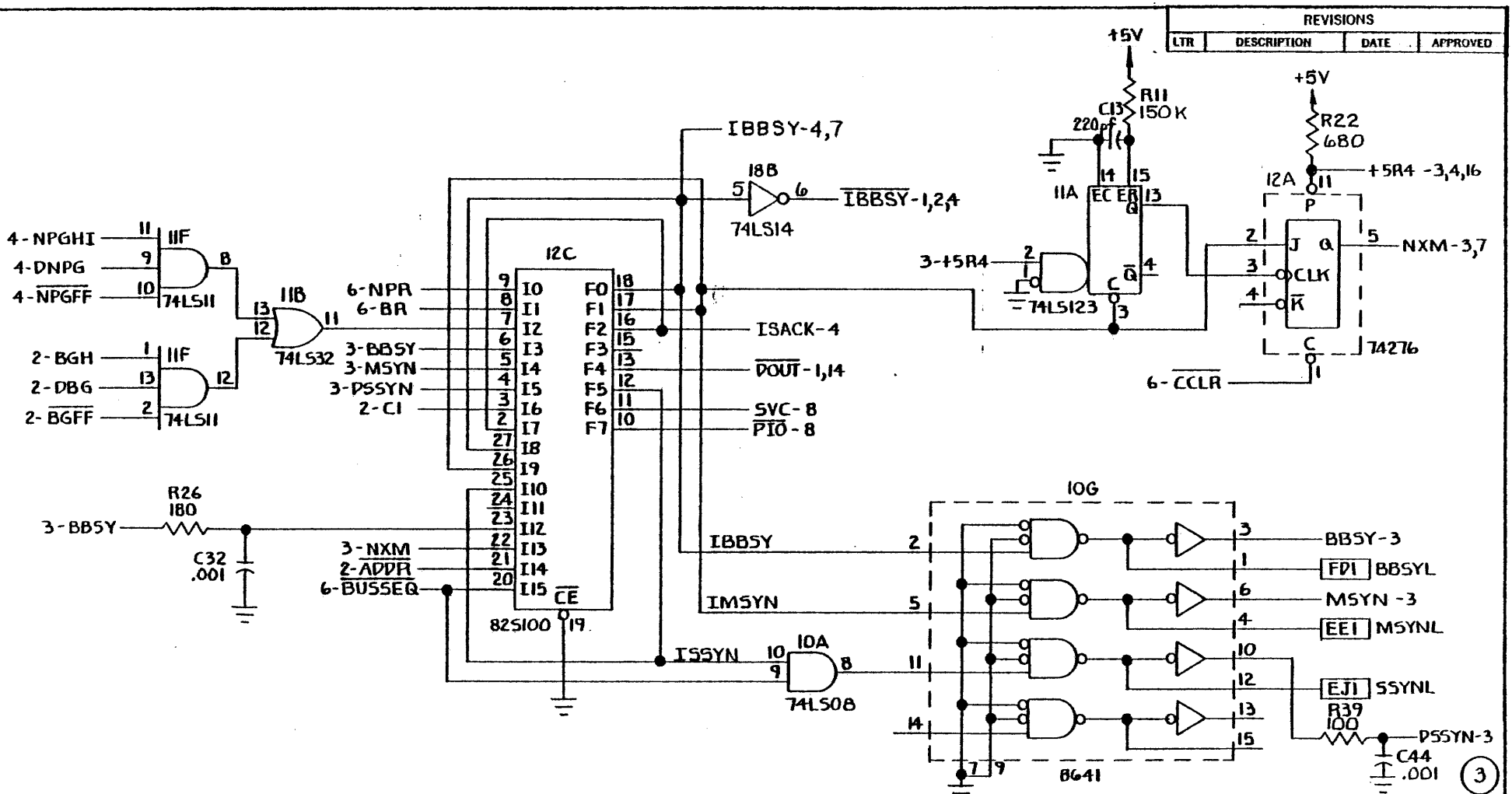

REVISIONS			
LTR	DESCRIPTION	DATE	APPROVED

TOLERANCES UNLESS OTHERWISE SPECIFIED	
FRACTIONS	DEC. ANGLES
±	±
APPROVALS	DATE
DRAWN L. FRANZKE	10-28-80
CHECKED HD KOGA	11-10-80

western peripherals™  
TUSTIN, CALIFORNIA

### PDP-11 BUS CTRL AND NXM

SCALE	SIZE	DRAWING NO.
	B	75000539
DO NOT SCALE DRAWING		SHEET 4 OF 27

REVISIONS			
LTR	DESCRIPTION	DATE	APPROVED

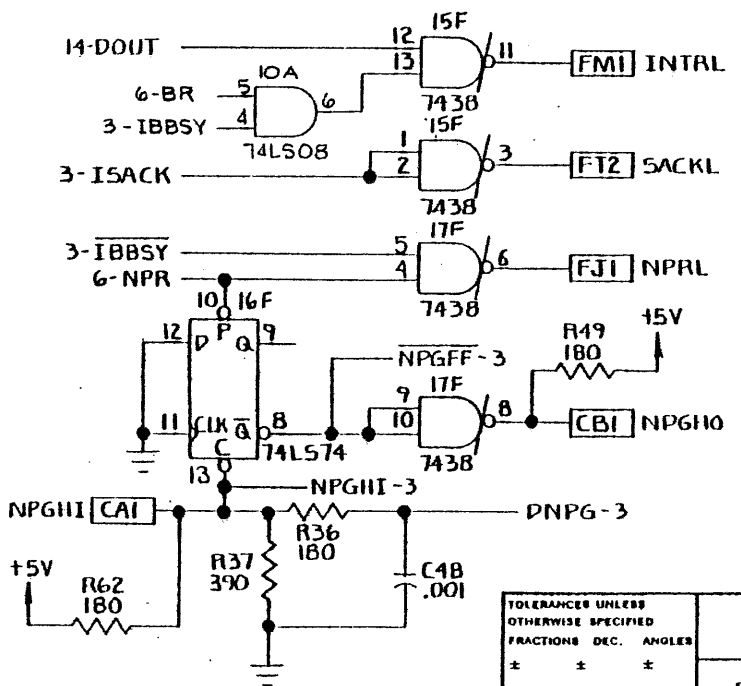
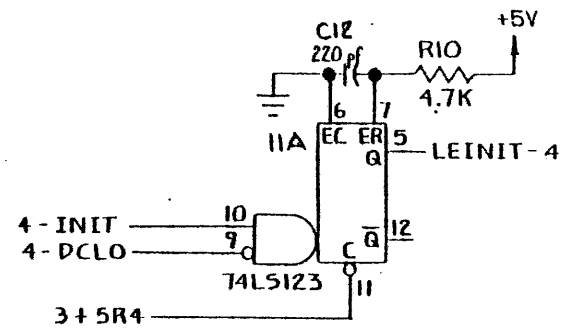
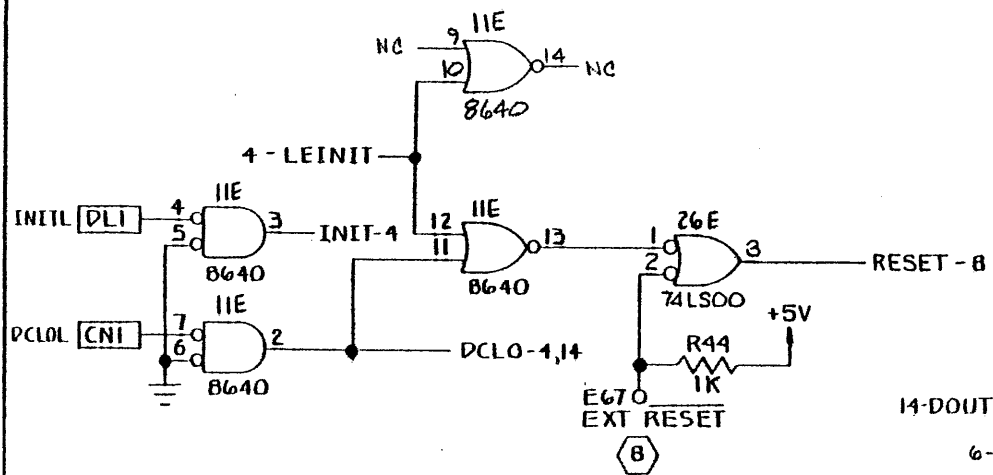

4

TOLERANCES UNLESS OTHERWISE SPECIFIED	
FRACTIONS DEC.	ANGLES
±	±
APPROVALS	DATE
DRAWN L. FRANZKE	10-28-80
CHECKED H.D. KOGA	11-10-80

**western peripherals™**  
 TUSTIN, CALIFORNIA

**PDP-11 INIT, DCLO, AND  
 NPR GRANT**

SCALE	SIZE	DRAWING NO.
	B	75000539

DO NOT SCALE DRAWING      SHEET 5 OF 27

FOR "B" REV NETWORK ONLY

REVISIONS			
LTR	DESCRIPTION	DATE	APPROVED

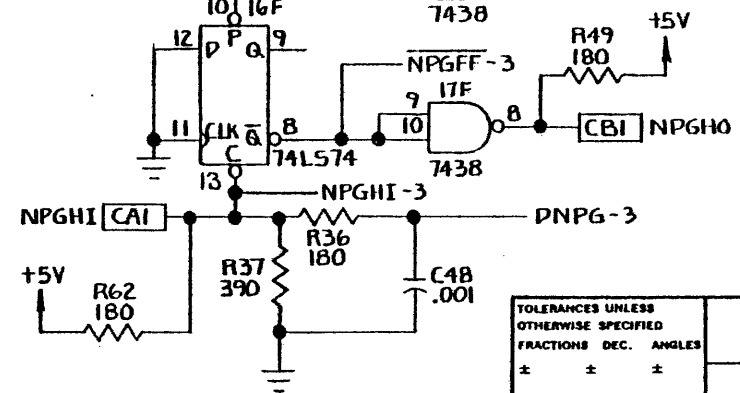
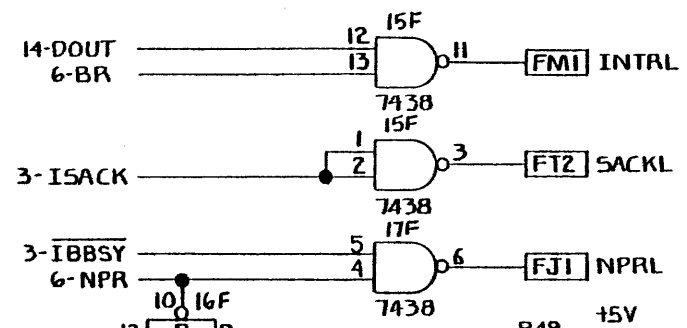
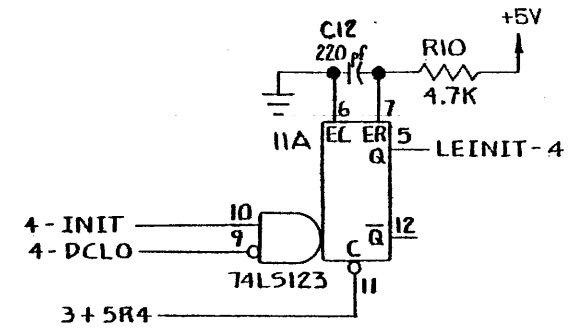
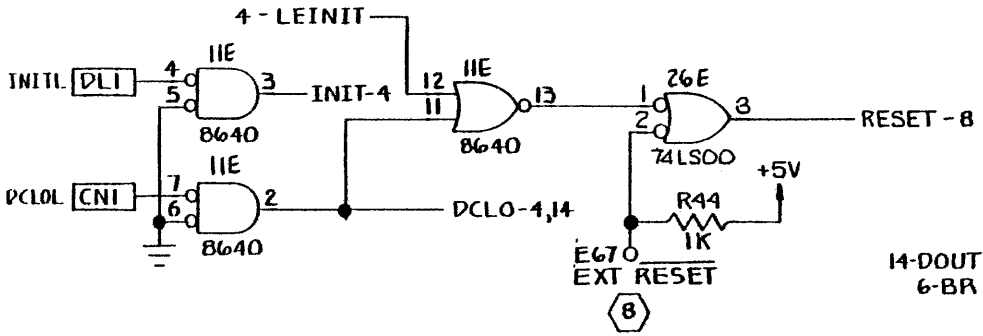

4

TOLERANCES UNLESS OTHERWISE SPECIFIED FRACTIONS DEC. ANGLES ± ± ±		 western peripherals™ TUSTIN, CALIFORNIA	
APPROVALS		DATE	
DRAWN L. FRANZKE		10-28-80	
CHECKED HD KOGA		11-10-80	
SCALE		SIZE B	DRAWING NO. 75000539
DO NOT SCALE DRAWING			SHEET 5 OF 27

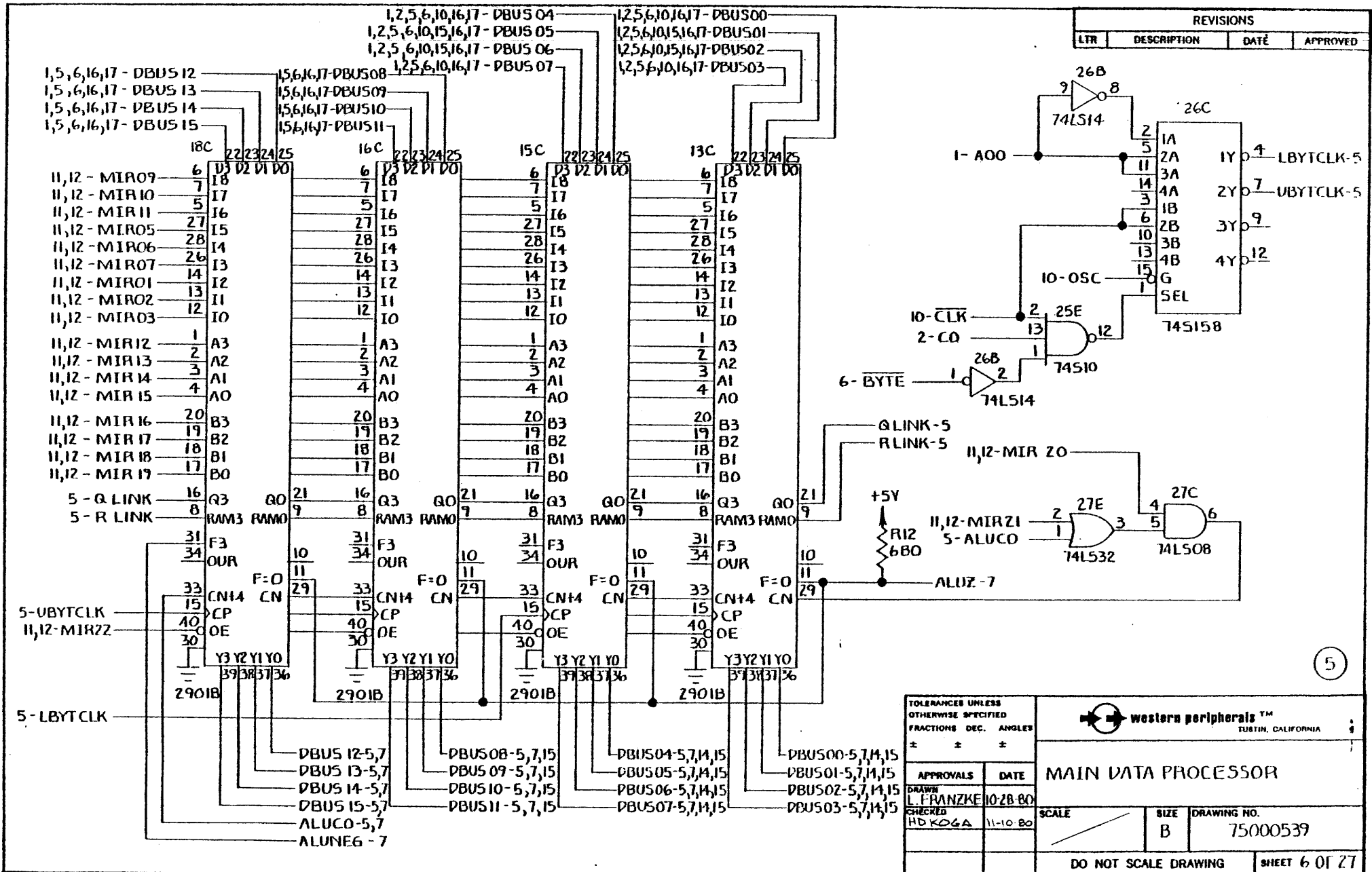

REVISIONS			
LTR	DESCRIPTION	DATE	APPROVED

5

TOLERANCES UNLESS OTHERWISE SPECIFIED FRACTIONS DEC. ANGLES ± ± ±		<b>western peripherals™</b> TUSTIN, CALIFORNIA	
APPROVALS		DATE	
DRAWN L. FRANZKE		10-28-80	
CHECKED HD KOGA		11-10-80	
SCALE		SIZE	DRAWING NO.
		B	75000539
DO NOT SCALE DRAWING			SHEET 6 OF 27

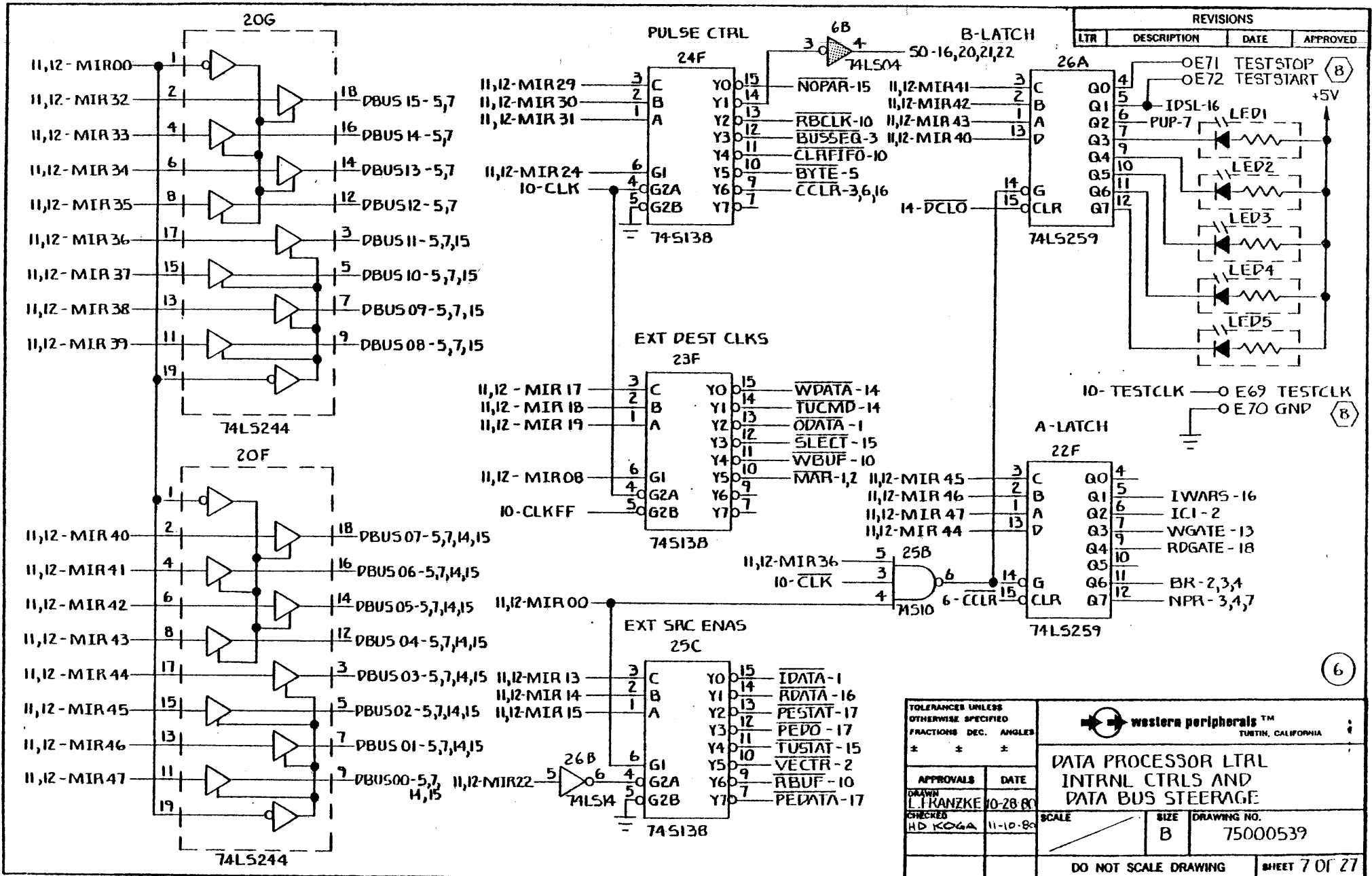

TOLERANCES UNLESS OTHERWISE SPECIFIED			western peripherals™ TURTIN, CALIFORNIA		
FRACTIONS	DEC.	ANGLES			
±	±	±	<b>DATA PROCESSOR LTR</b> <b>INTRNL CTRLS AND</b> <b>DATA BUS STEERING</b>		
APPROVALS	DATE				
DESIGN L. KRANZKE	10-28-80		SCALE	SIZE	DRAWING NO.
CHECKED HD KOGA	11-10-80			B	75000539
DO NOT SCALE DRAWING					SHEET 7 OF 27

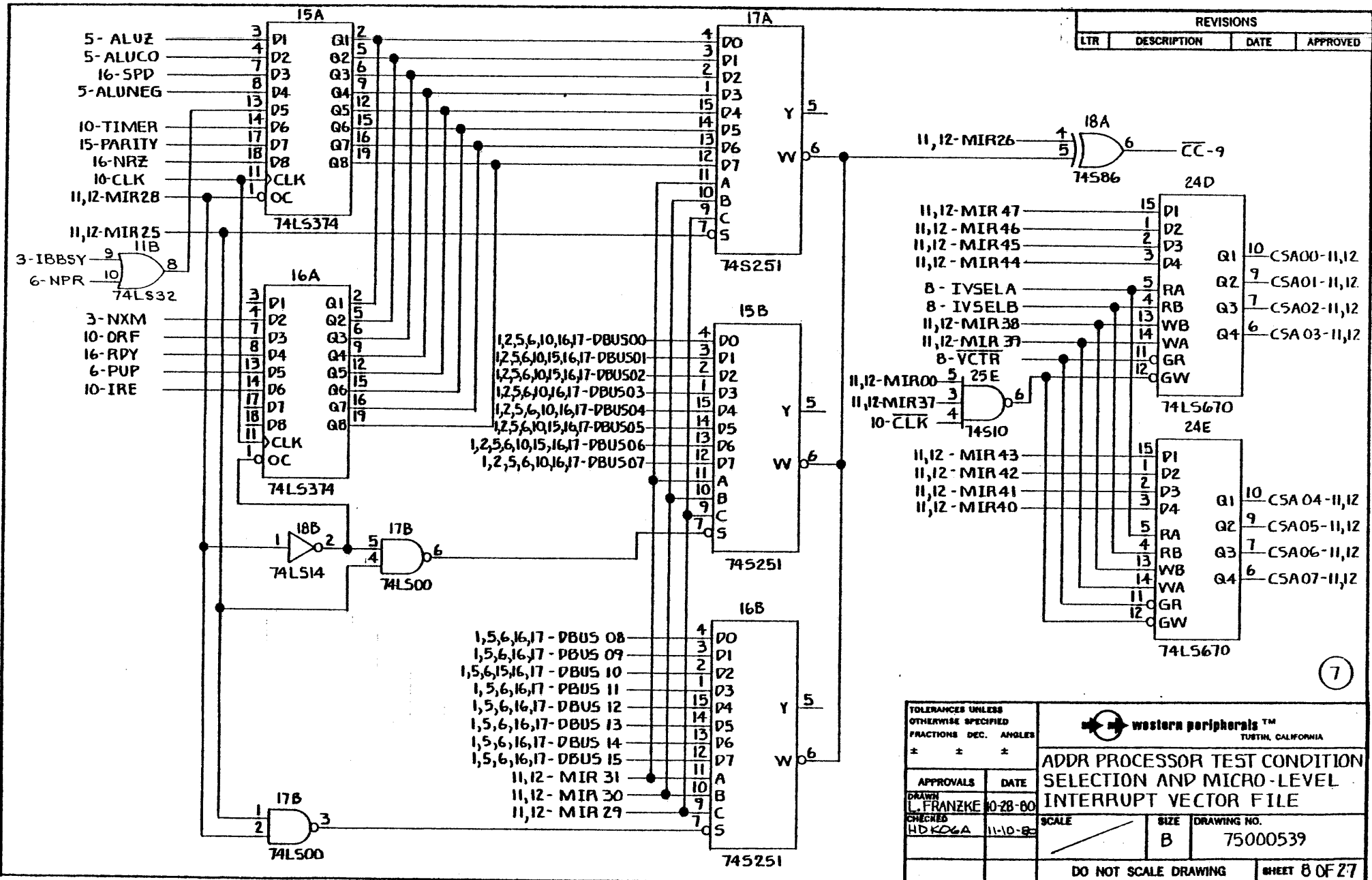

7

TOLERANCES UNLESS OTHERWISE SPECIFIED  
FRACTIONS DEC. ANGLES  
± ± ±

**western peripherals™**  
TUSTIN, CALIFORNIA

**ADDR PROCESSOR TEST CONDITION  
SELECTION AND MICRO-LEVEL  
INTERRUPT VECTOR FILE**

APPROVALS	DATE	SCALE	SIZE	DRAWING NO.
DRAWN L. FRANZKE	10-28-80		B	75000539
CHECKED HD KOGA	11-10-80			

DO NOT SCALE DRAWING    SHEET 8 OF 27

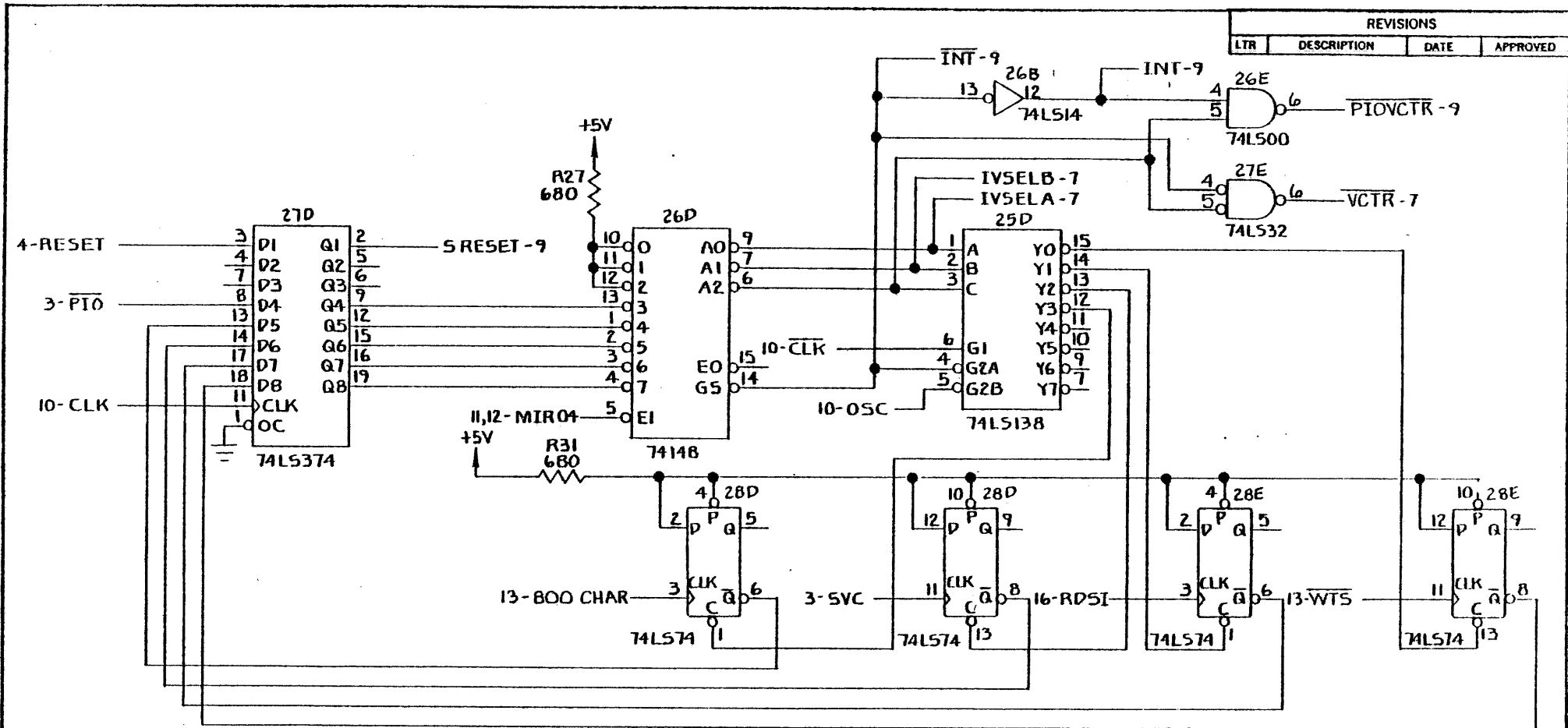

REVISIONS			
LTR	DESCRIPTION	DATE	APPROVED

(B)

TOLERANCES UNLESS OTHERWISE SPECIFIED FRACTIONS DEC. ANGLES * * *		<b>western peripherals™</b> TUSTIN, CALIFORNIA	
<b>MICRO-LEVEL INTERRUPT CTRL.</b>			
APPROVALS	DATE	SCALE	SIZE DRAWING NO.
DRAWN L. FRANZKE	10-28-80	/	B 75000539
CHECKED H.D. KOEHLER	11-10-80		
DO NOT SCALE DRAWING			SHEET 9 OF 27

REVISIONS			
LTR	DESCRIPTION	DATE	APPROVED

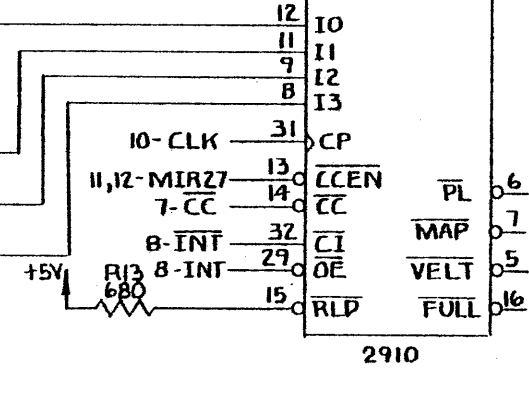
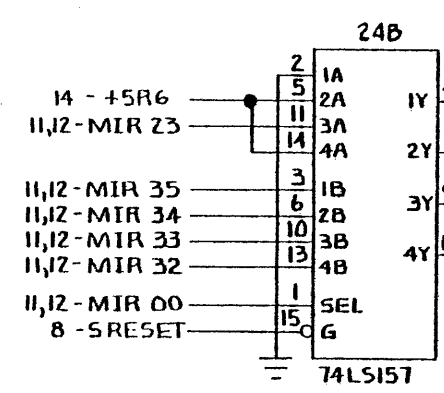
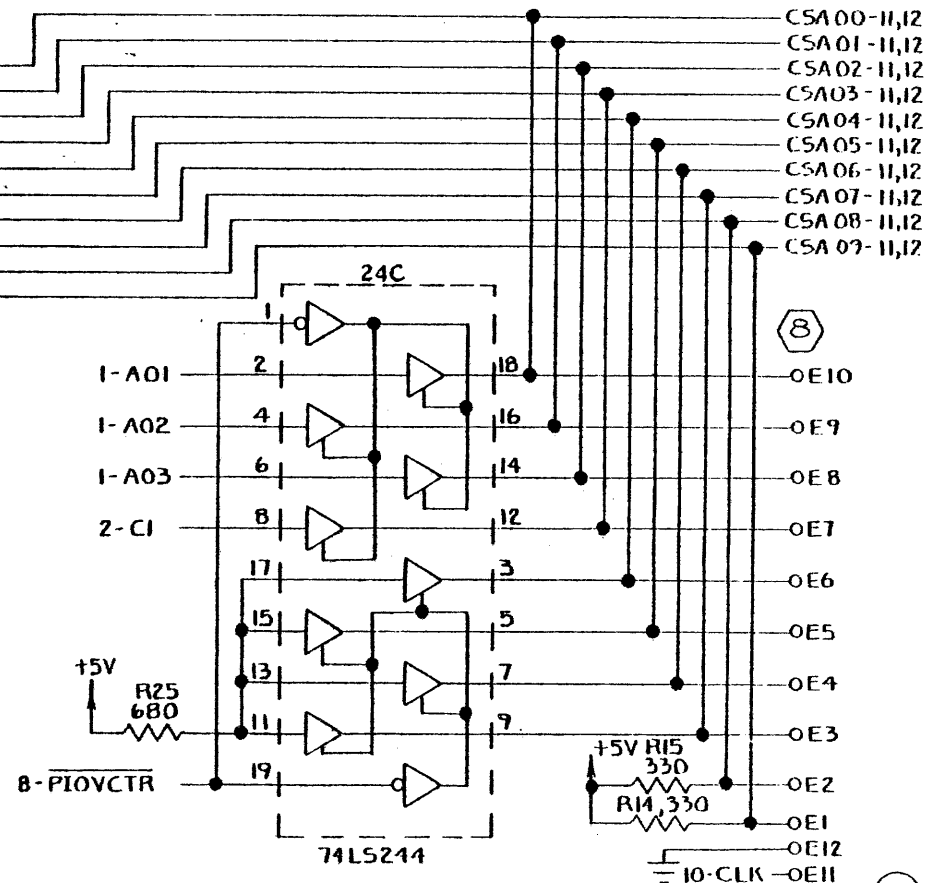
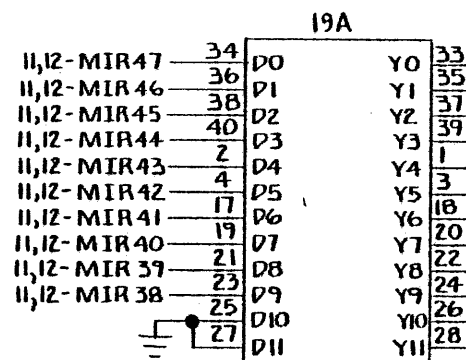

- CSA00-11,12
- CSA01-11,12
- CSA02-11,12
- CSA03-11,12
- CSA04-11,12
- CSA05-11,12
- CSA06-11,12
- CSA07-11,12
- CSA08-11,12
- CSA09-11,12

- 1-A01
- 1-A02
- 1-A03
- 2-CI
- 18
- 16
- 14
- 12
- 3
- 5
- 7
- 9
- 17
- 15
- 13
- 11
- 19
- OE10
- OE9
- OE8
- OE7
- OE6
- OE5
- OE4
- OE3
- OE2
- OE1
- OE12
- OE11

TOLERANCES UNLESS OTHERWISE SPECIFIED	
FRACTIONS DEC. ANGLES	
± ± ±	
APPROVALS	DATE
DRAWN L. FRANZKE	10-28-80
CHECKED H. D. KOGA	11-10-80

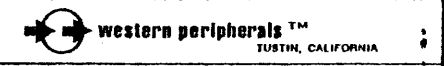

ADDR PROCESSOR

SCALE	SIZE B	DRAWING NO. 75000539
DO NOT SCALE DRAWING		SHEET 10 OF 27



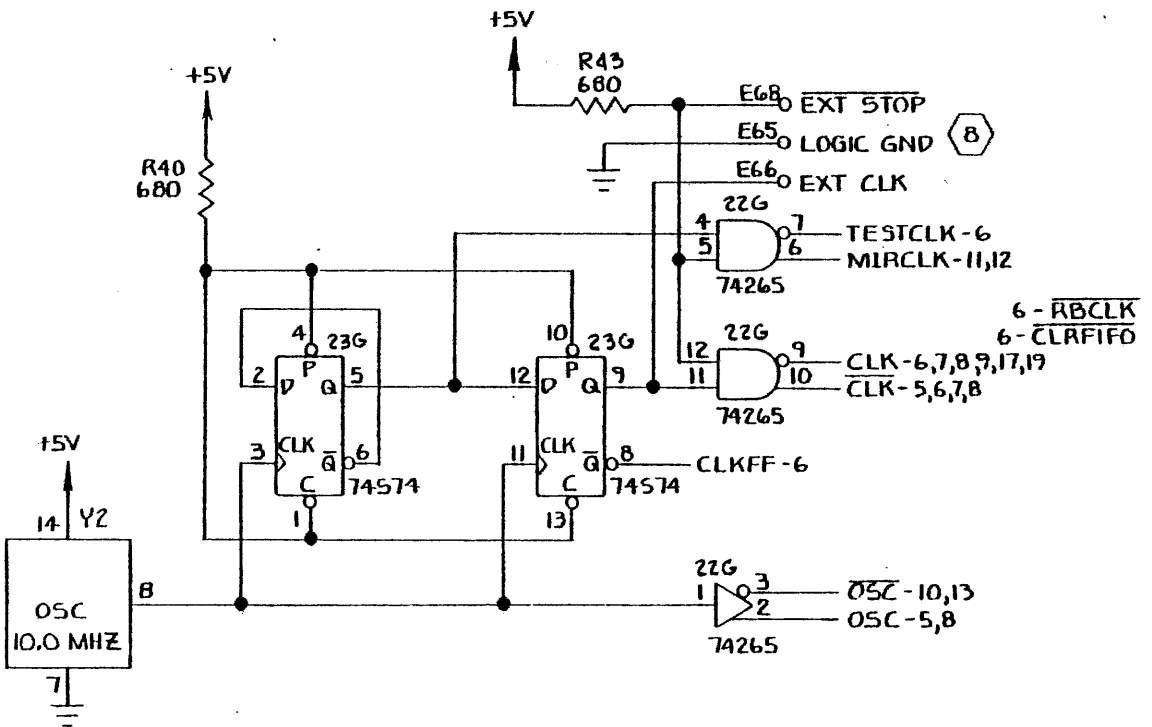
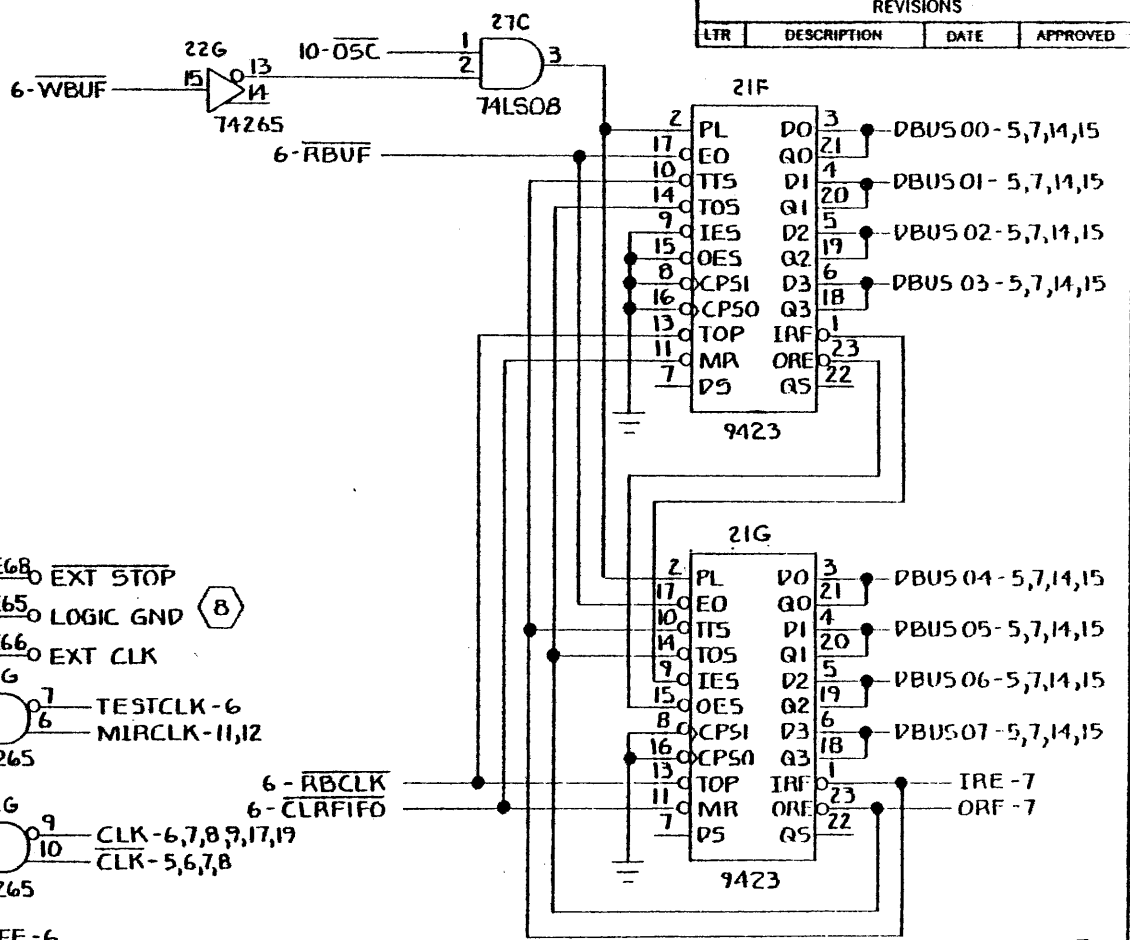
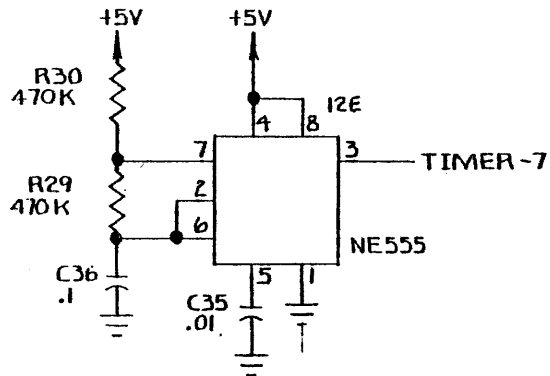

REVISIONS			
LTR	DESCRIPTION	DATE	APPROVED

TOLERANCES UNLESS OTHERWISE SPECIFIED	
FRACTIONS DEC. ANGLES	
±	±
APPROVALS	DATE
DRAWN L. FRANZKE	10-28-80
CHECKED HD KOGA	11-10-80

western peripherals™  
TUSTIN, CALIFORNIA

### TIMER CLOCK GENERATION DATA BUFFER

SCALE	SIZE	DRAWING NO.
	B	75000539

DO NOT SCALE DRAWING      SHEET 11 OF 27

(10)

REVISIONS			
LTR	DESCRIPTION	DATE	APPROVED

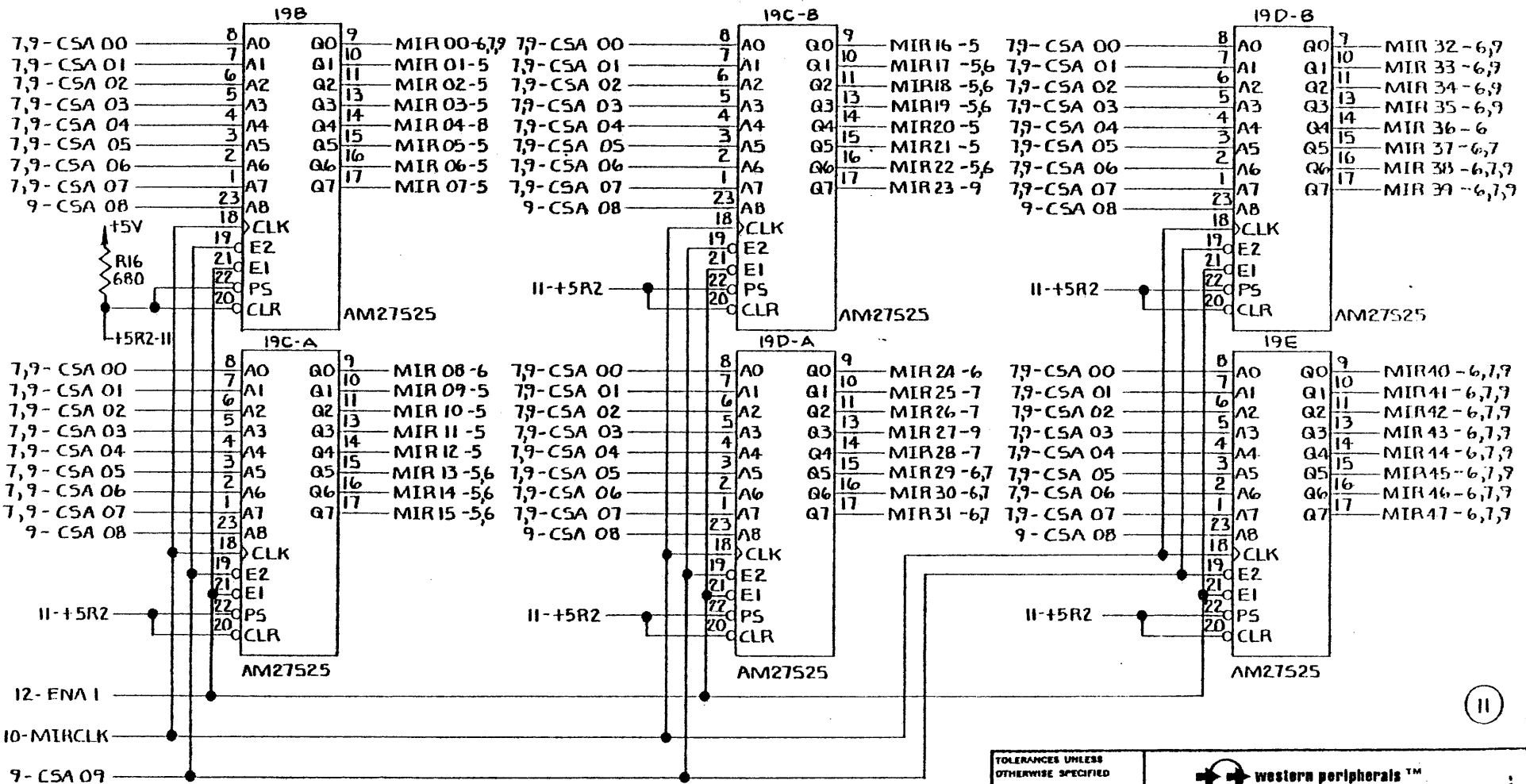

TOLERANCES UNLESS OTHERWISE SPECIFIED FRACTIONS DEC. ANGLES ± ± ±		 western peripherals™ TUSTIN, CALIFORNIA	
APPROVALS		DATE	
DRAWN L. FRANZKE		10-28-80	
CHECKED HP KOGA		11-10-80	
SCALE		SIZE	DRAWING NO.
		B	75000539
DO NOT SCALE DRAWING			SHEET 12 OF 27

REVISIONS			
LTR	DESCRIPTION	DATE	APPROVED

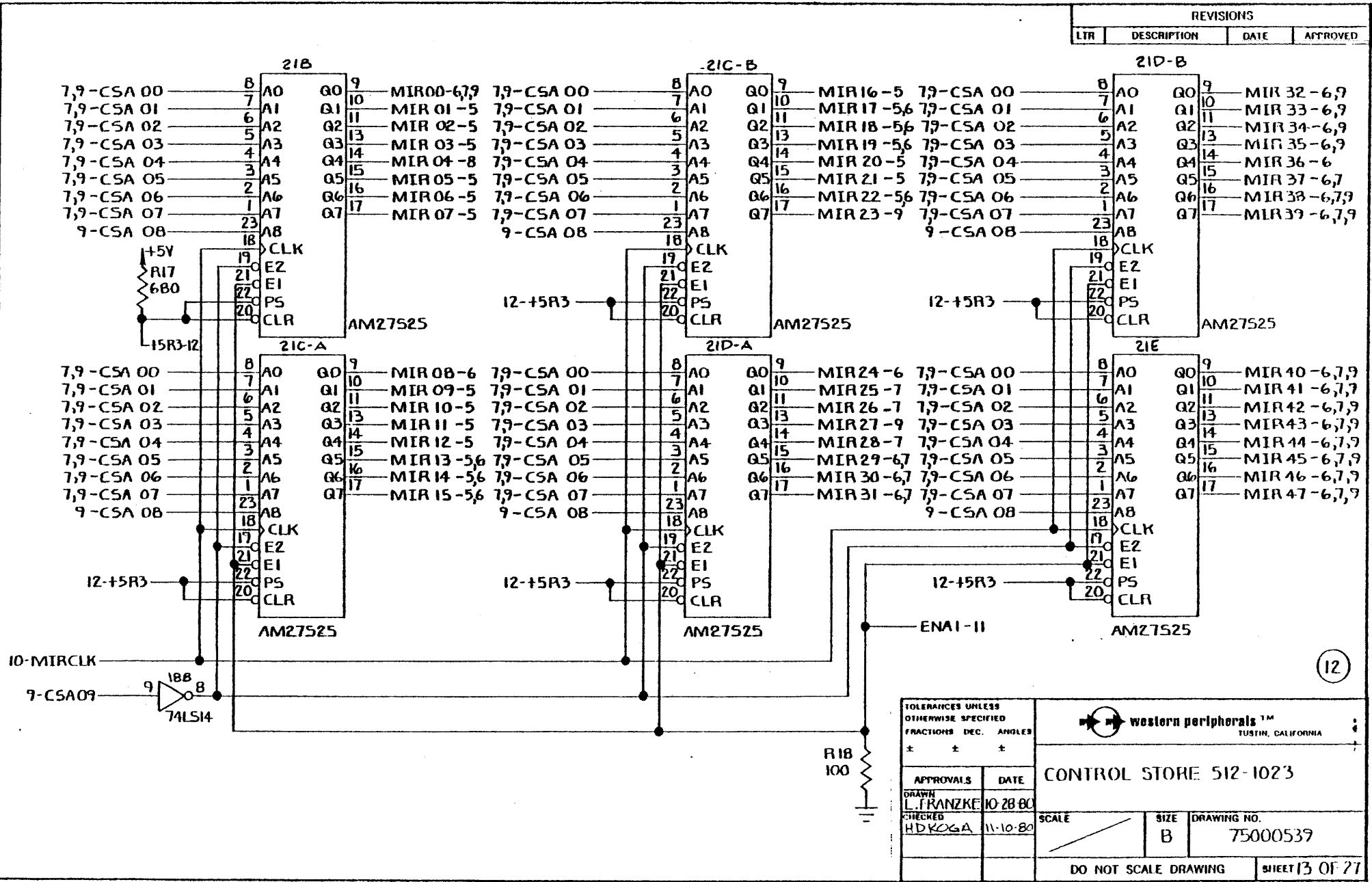

TOLERANCES UNLESS OTHERWISE SPECIFIED		western peripherals™	
FRACTIONS DEC. ANGLES		TUSTIN, CALIFORNIA	
* * *		CONTROL STORE 512-1023	
APPROVALS	DATE	SCALE	SIZE DRAWING NO.
DRAWN L. FRANZKE	10-28-80		B 75000539
CHECKED HDKOGA	11-10-80		
DO NOT SCALE DRAWING			SHEET 13 OF 27

12

REVISIONS			
LTR	DESCRIPTION	DATE	APPROVED

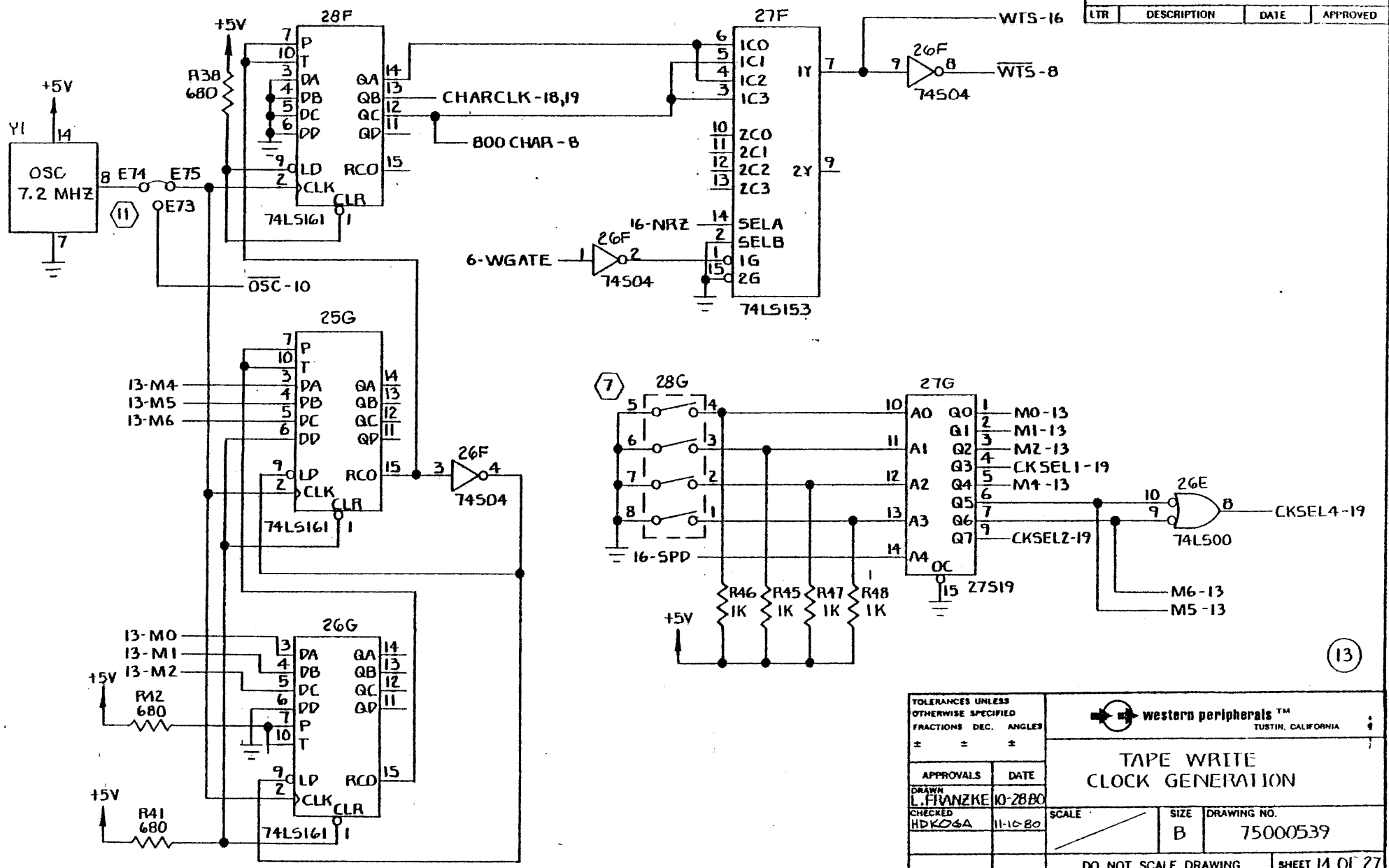

TOLERANCES UNLESS OTHERWISE SPECIFIED			<b>western peripherals™</b> TUSTIN, CALIFORNIA		
FRACTIONS	DEC.	ANGLES			
±	±	±	<b>TAPE WRITE CLOCK GENERATION</b>		
APPROVALS	DATE				
DRAWN L. FRANZKE	10-28-80		SCALE	SIZE B	DRAWING NO. 75000539
CHECKED HDK06A	11-10-80		DO NOT SCALE DRAWING		
			SHEET 14 OF 27		

REVISIONS			
LTR	DESCRIPTION	DATE	APPROVED

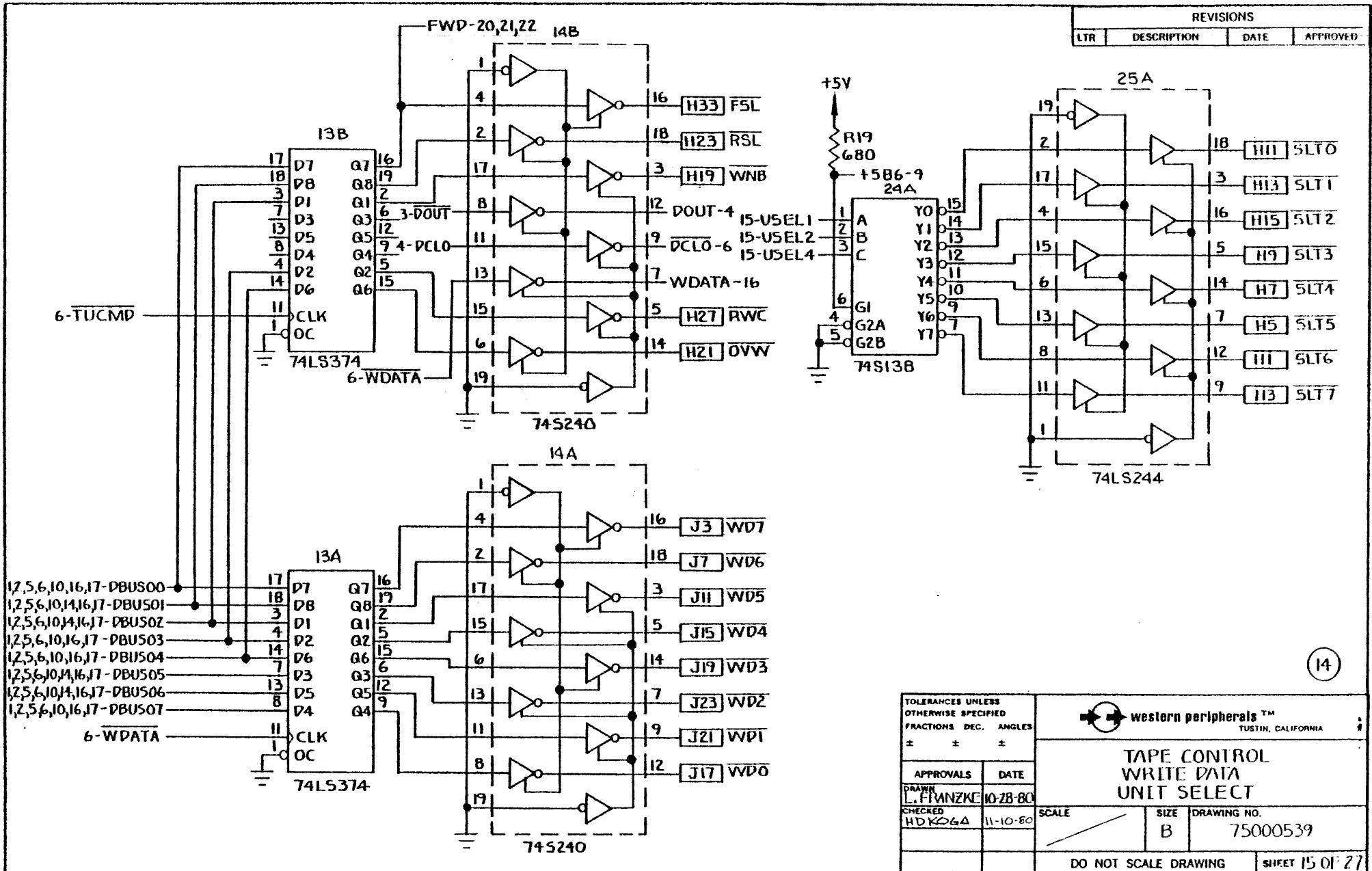

(14)

TOLERANCES UNLESS OTHERWISE SPECIFIED FRACTIONS DEC. ANGLES ± ± ±		<b>western peripherals™</b> TUSTIN, CALIFORNIA	
APPROVALS		DATE	
DRAWN L. FRANZKE		10-28-80	
CHECKED HDK/GA		11-10-80	
SCALE		SIZE B	DRAWING NO. 75000539
DO NOT SCALE DRAWING			SHIFET 15 01' 27

REVISIONS			
LTR	DESCRIPTION	DATE	APPROVED

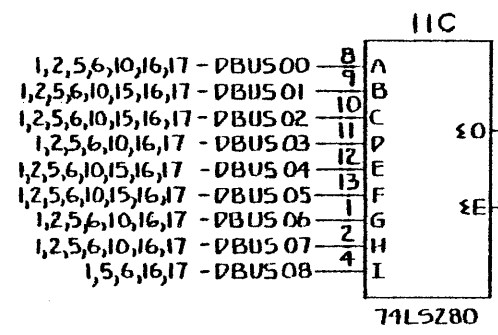
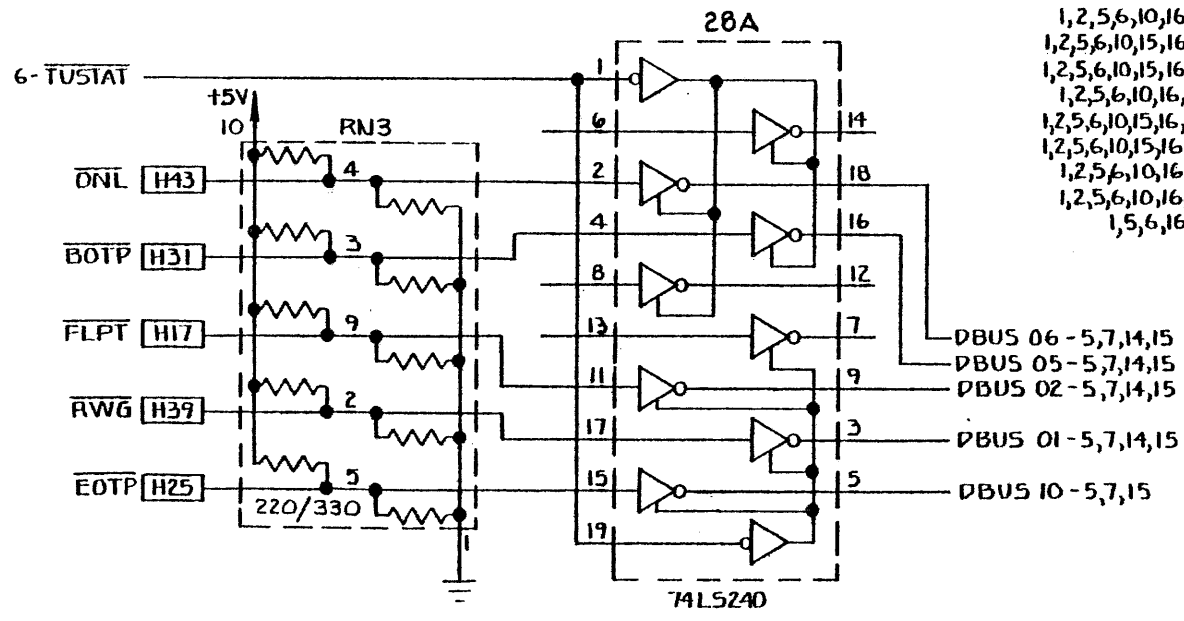
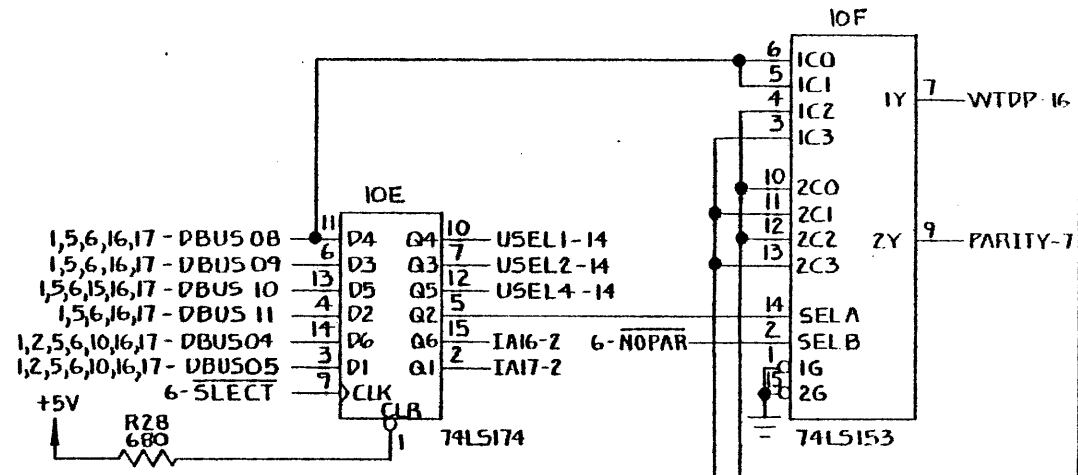

15

TOLERANCES UNLESS OTHERWISE SPECIFIED FRACTIONS DEC. ANGLES ± ± ±		western peripherals™ TUSTIN, CALIFORNIA	
APPROVALS		DATE	
DRAWN L. FRANZKE		10-28-80	
CHECKED H.D. KOZA		11-10-80	
SCALE		SIZE B	DRAWING NO. 75000539
DO NOT SCALE DRAWING			SHEET 16 OF 27



FOR "B" REV NETWORK ONLY

REVISIONS			
LTR	DESCRIPTION	DATE	APPROVED

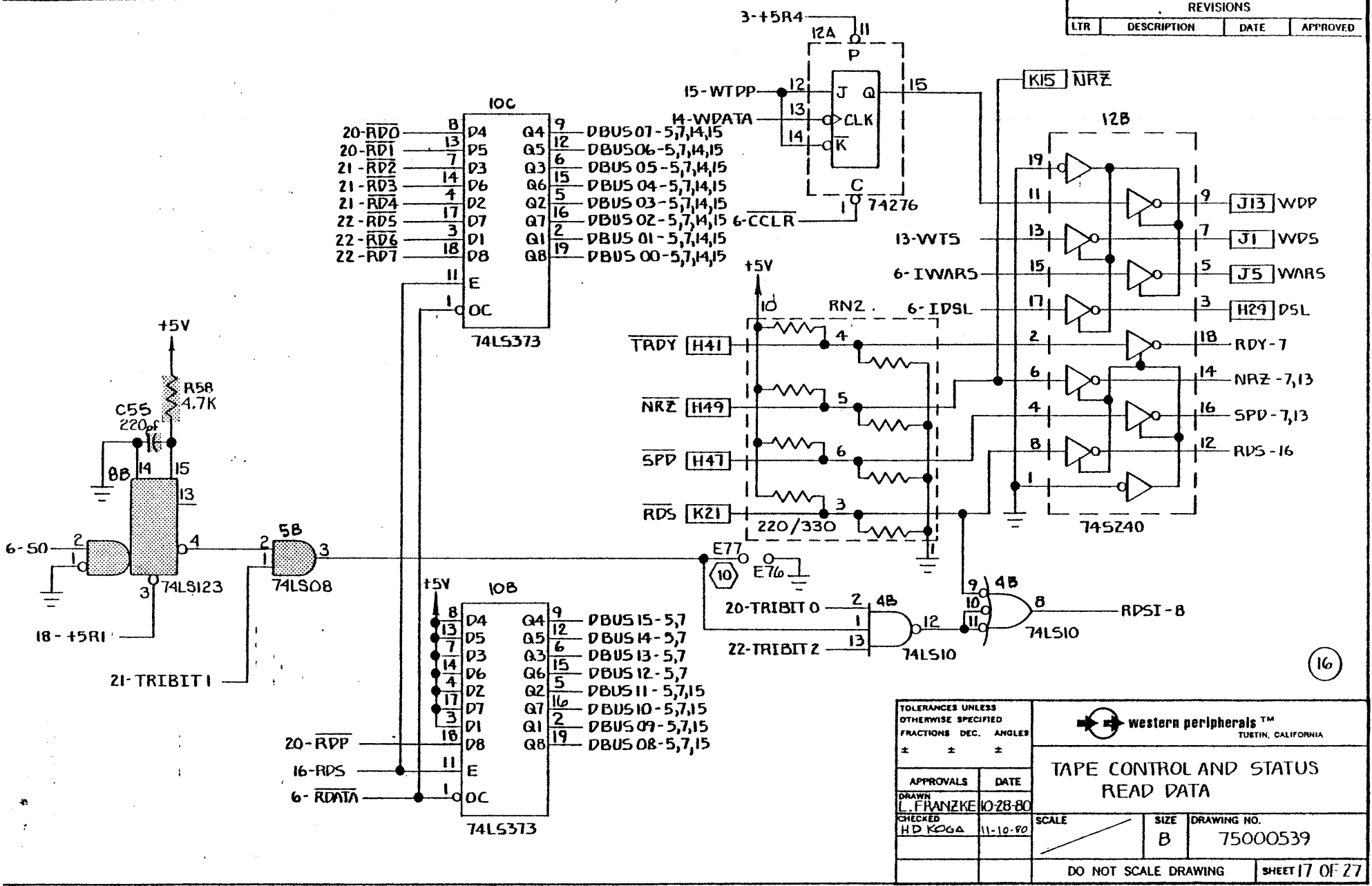

16

TOLERANCES UNLESS OTHERWISE SPECIFIED FRACTIONS DEC. ANGLES			western peripherals™ TUSTIN, CALIFORNIA		
±	±	±			
APPROVALS		DATE	TAPE CONTROL AND STATUS READ DATA		
DRAWN L. FRANZKE		10-28-80			
CHECKED HD KOGA		11-10-80	SCALE	SIZE B	DRAWING NO. 75000539
DO NOT SCALE DRAWING				SHEET 17 OF 27	



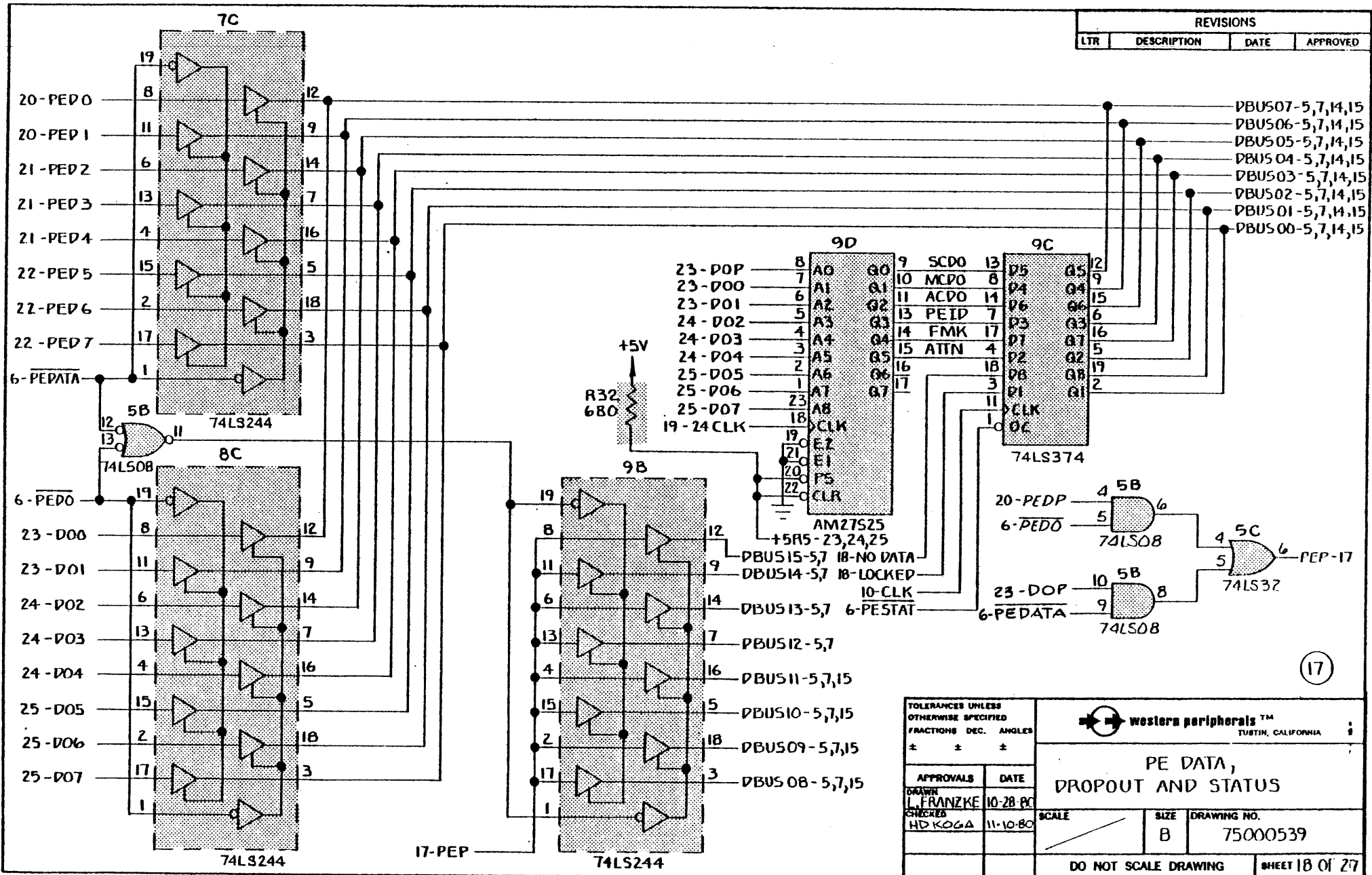

17

TOLERANCES UNLESS OTHERWISE SPECIFIED  
FRACTIONS DEC. ANGLES  
± ± ±

**western peripherals™**  
TUSTIN, CALIFORNIA

**PE DATA,  
DROPOUT AND STATUS**

APPROVALS	DATE	SCALE	SIZE	DRAWING NO.
DRAWN L. FRANZKE	10-28-80		B	75000539
CHECKED HD KOGA	11-10-80			

DO NOT SCALE DRAWING SHEET 18 OF 27

REVISIONS			
LTR	DESCRIPTION	DATE	APPROVED

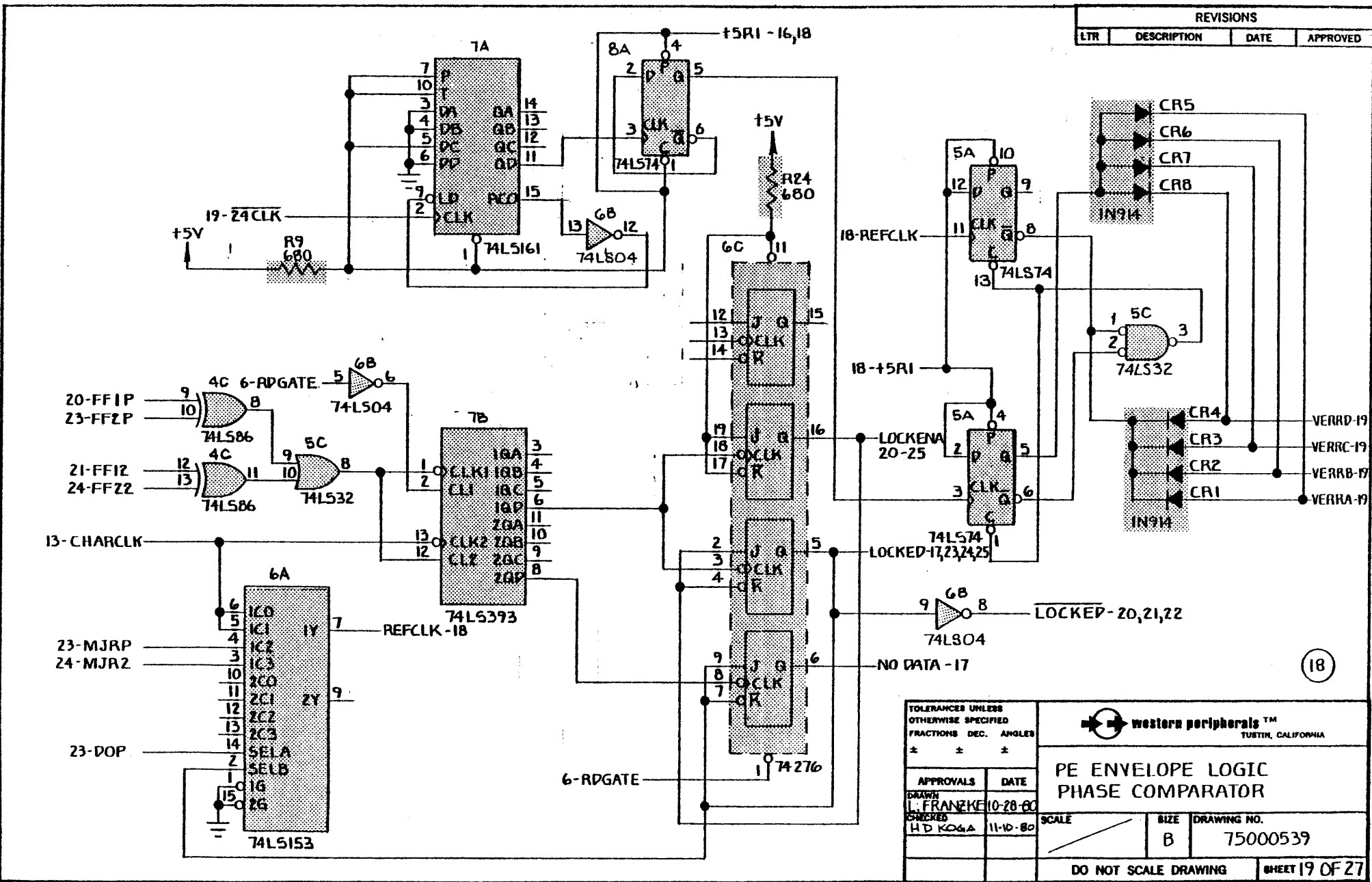

TOLERANCES UNLESS OTHERWISE SPECIFIED	
FRACTIONS	DEC. ANGLES
±	±
APPROVALS	DATE
DRAWN L. FRANZKE	10-20-80
CHECKED H.D. KOZA	11-10-80

 western peripherals™ TUSTIN, CALIFORNIA		
<b>PE ENVELOPE LOGIC PHASE COMPARATOR</b>		
SCALE	SIZE	DRAWING NO.
	B	75000539
DO NOT SCALE DRAWING		SHEET 19 OF 27

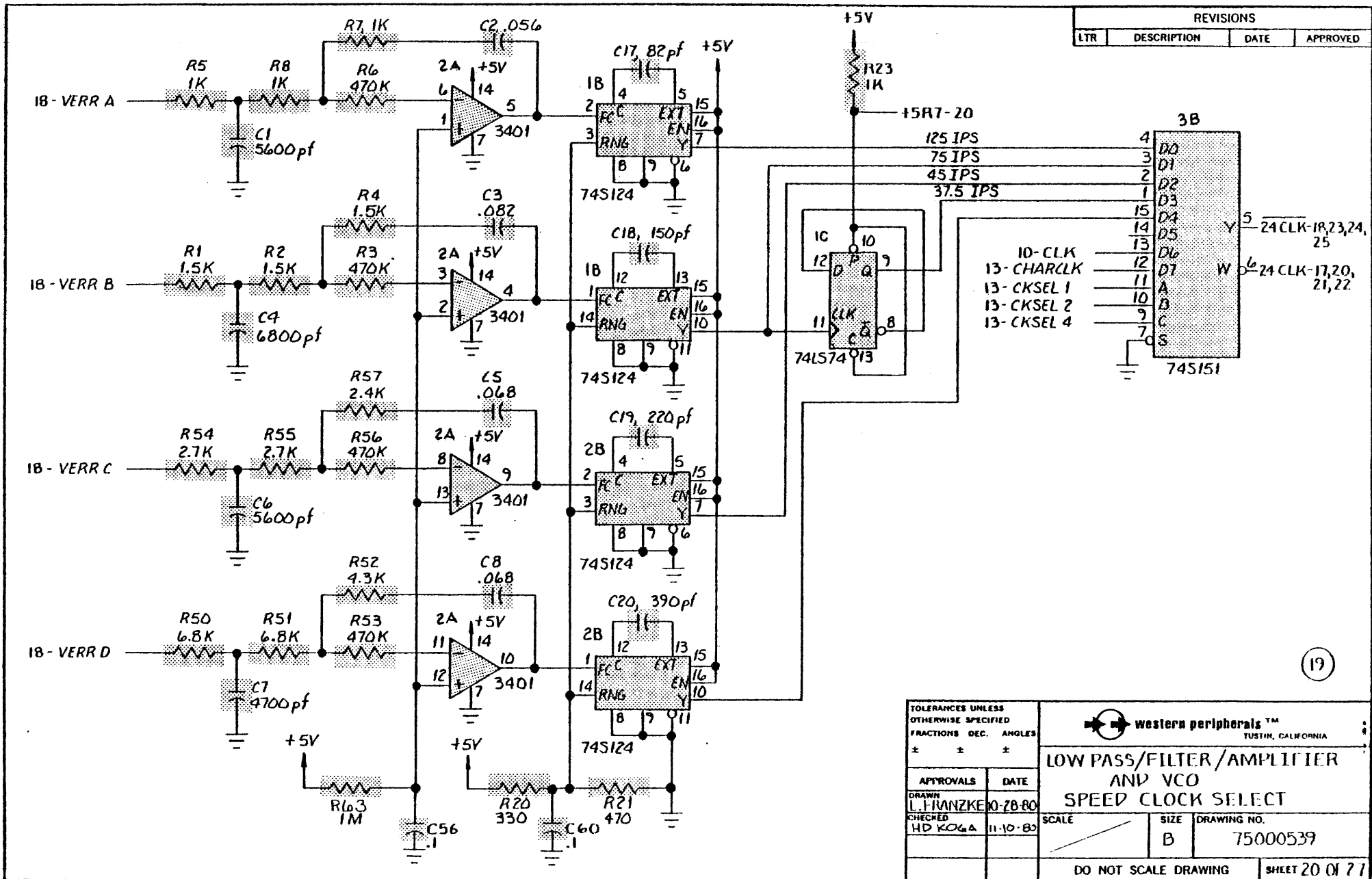

REVISIONS			
LTR	DESCRIPTION	DATE	APPROVED

(19)

TOLERANCES UNLESS OTHERWISE SPECIFIED		 western peripherals™ TUSTIN, CALIFORNIA	
FRACTIONS DEC.	ANGLES		
±	±	LOW PASS/FILTER/AMPLIFIER AND VCO SPEED CLOCK SELECT	
APPROVALS	DATE	SCALE	DRAWING NO.
DRAWN L. FRANZKE	10-28-80		75000539
CHECKED HD KOGA	11-10-80		
DO NOT SCALE DRAWING			SHEET 20 OF 27

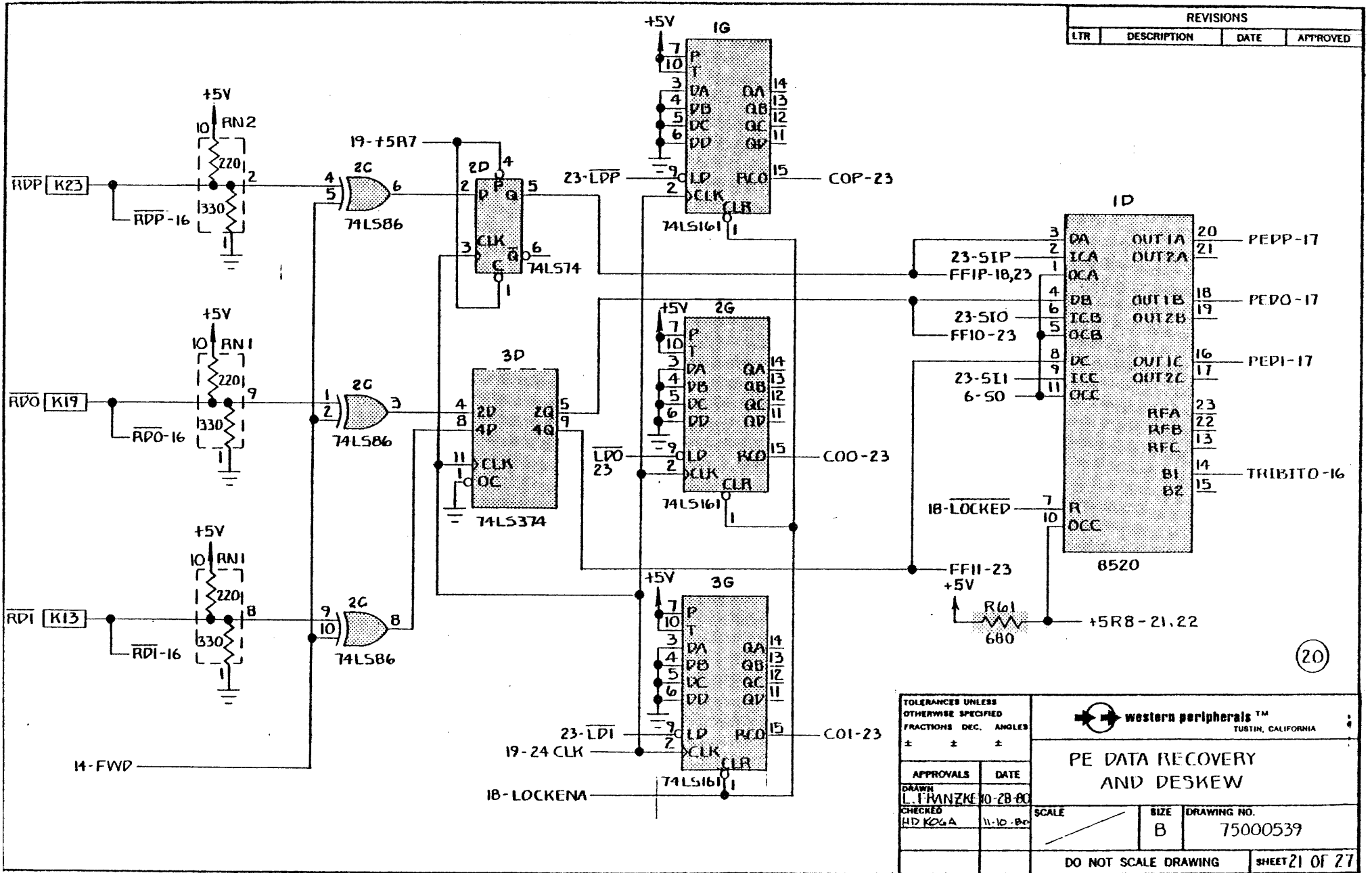

REVISIONS			
LTR	DESCRIPTION	DATE	APPROVED

(20)

TOLERANCES UNLESS OTHERWISE SPECIFIED  
 FRACTIONS DEC. ANGLES  
 ± ± ±

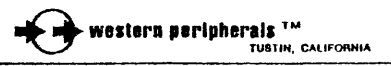

PE DATA RECOVERY AND DESKEW

APPROVALS	DATE
DRAWN L. FRANZKE	10-28-80
CHECKED HD KOGA	11-10-80

SCALE	SIZE B	DRAWING NO. 75000539
-------	-----------	-------------------------

DO NOT SCALE DRAWING SHEET 21 OF 27

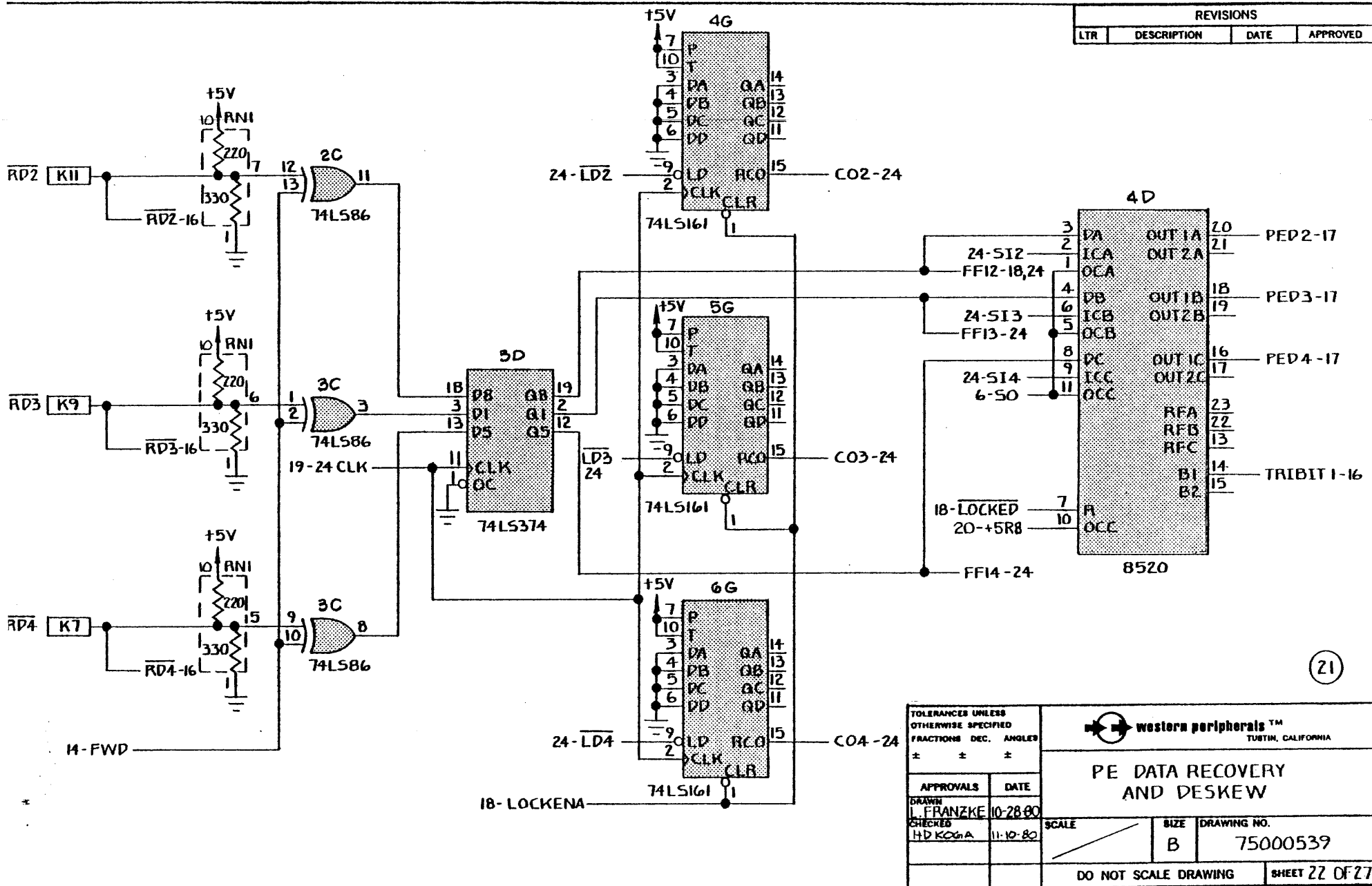

REVISIONS			
LTR	DESCRIPTION	DATE	APPROVED

(21)

TOLERANCES UNLESS OTHERWISE SPECIFIED FRACTIONS DEC. ANGLES		 western peripherals™ TUSTIN, CALIFORNIA	
±	±		
APPROVALS		DATE	
DRAWN L. FRANZKE		10-28-80	
CHECKED H.D. KOGMA		11-10-80	
SCALE		SIZE	DRAWING NO.
		B	75000539
DO NOT SCALE DRAWING			SHEET 22 OF 27

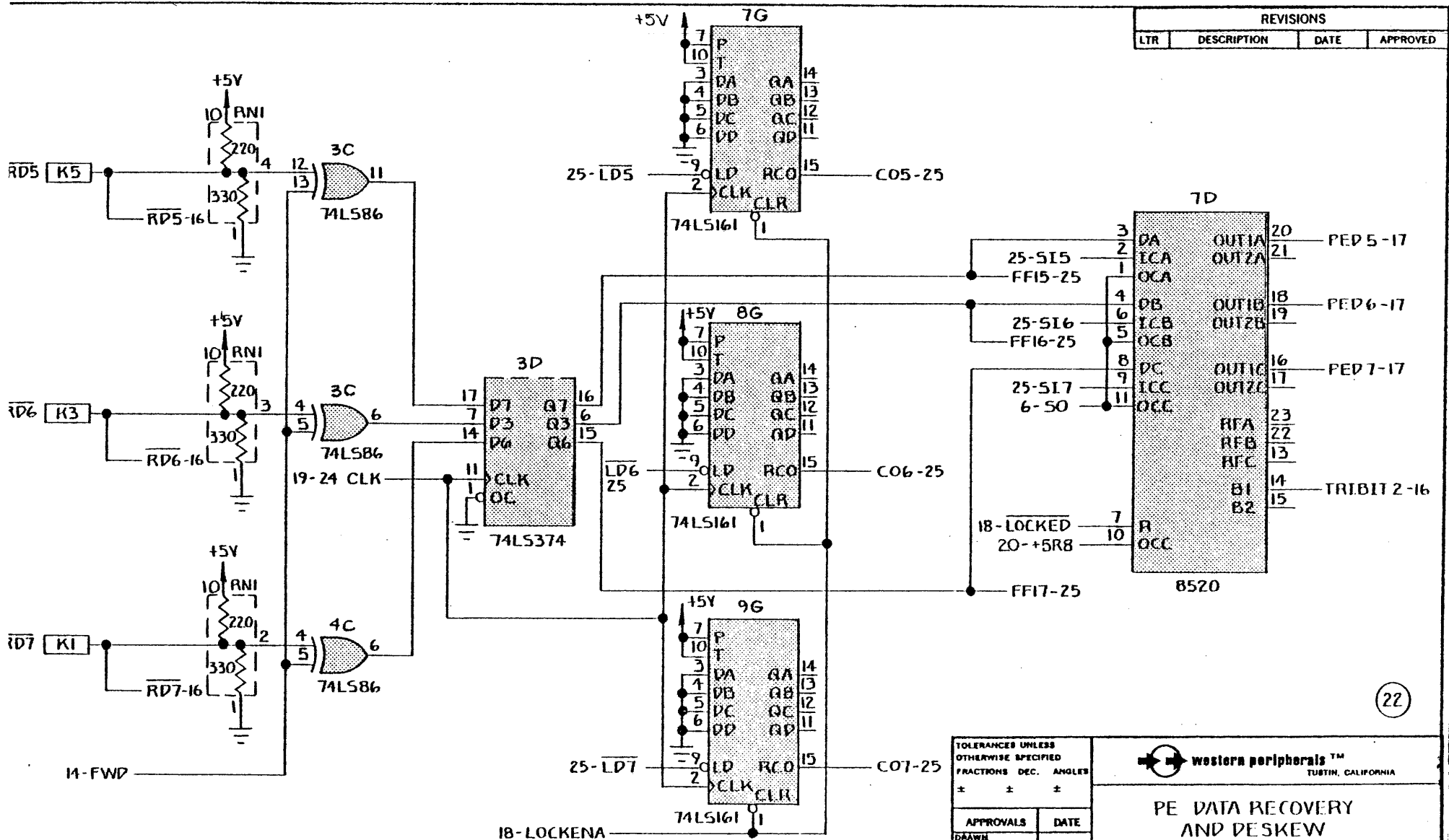

REVISIONS			
LTR	DESCRIPTION	DATE	APPROVED

(22)

TOLERANCES UNLESS OTHERWISE SPECIFIED FRACTIONS DEC. ANGLES ± ± ±		 <b>western peripherals™</b> TUSTIN, CALIFORNIA		
<b>PE DATA RECOVERY AND DESKEW</b>				
APPROVALS	DATE	SCALE	SIZE	DRAWING NO.
DRAWN L. FRANZKE	10-28-80			
CHECKED HD KOA	11-10-80	DO NOT SCALE DRAWING		SHEET 23 OF 27

REVISIONS			
LTR	DESCRIPTION	DATE	APPROVED

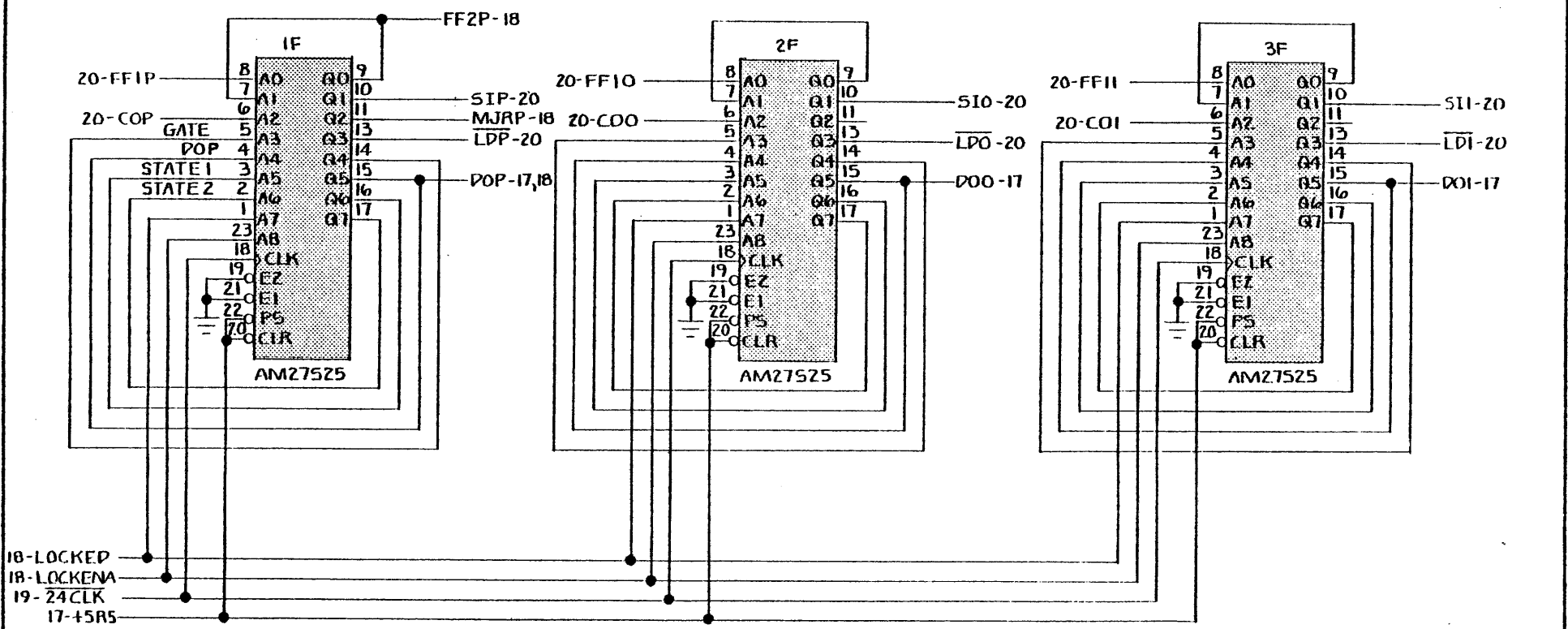

(23)

TOLERANCES UNLESS OTHERWISE SPECIFIED FRACTIONS DEC. ANGLES * * *		 <b>western peripherals™</b> TUSTIN, CALIFORNIA	
APPROVALS		DATE	
DRAWN L. FRANZKE		10-28-80	
CHECKED HD KO-A		11-10-80	
SCALE		SIZE B	DRAWING NO. 75000539
DO NOT SCALE DRAWING			SHEET 24 OF 27

REVISIONS			
LTR	DESCRIPTION	DATE	APPROVED

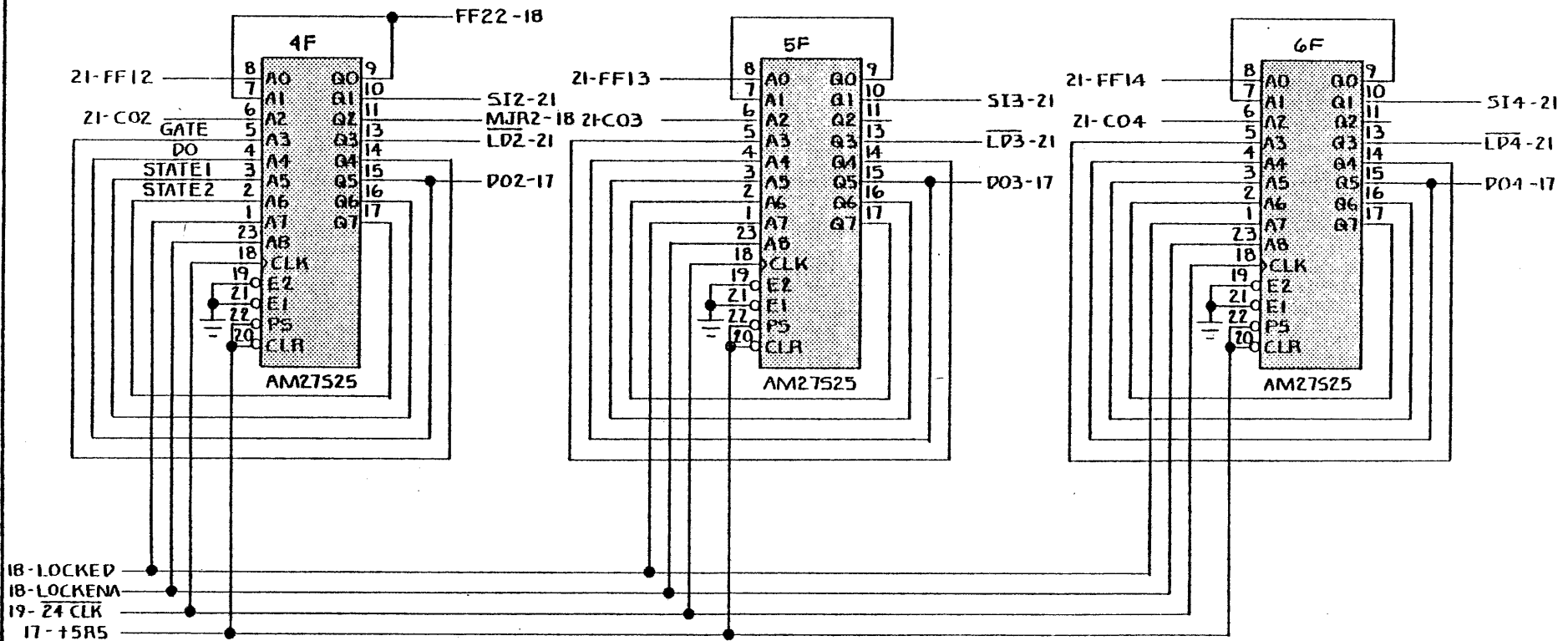

(24)

TOLERANCES UNLESS OTHERWISE SPECIFIED FRACTIONS DEC. ANGLES ± ± ±		 <b>western peripherals</b> ™ TUSTIN, CALIFORNIA	
APPROVALS		DATE	
DRAWN L. J. RANZKE		10-28-80	
CHECKED H.D. KOGA		11-10-80	
SCALE		SIZE B	DRAWING NO. 75000539
DO NOT SCALE DRAWING			SHEET 25 OF 27



REVISIONS			
LTR	DESCRIPTION	DATE	APPROVED

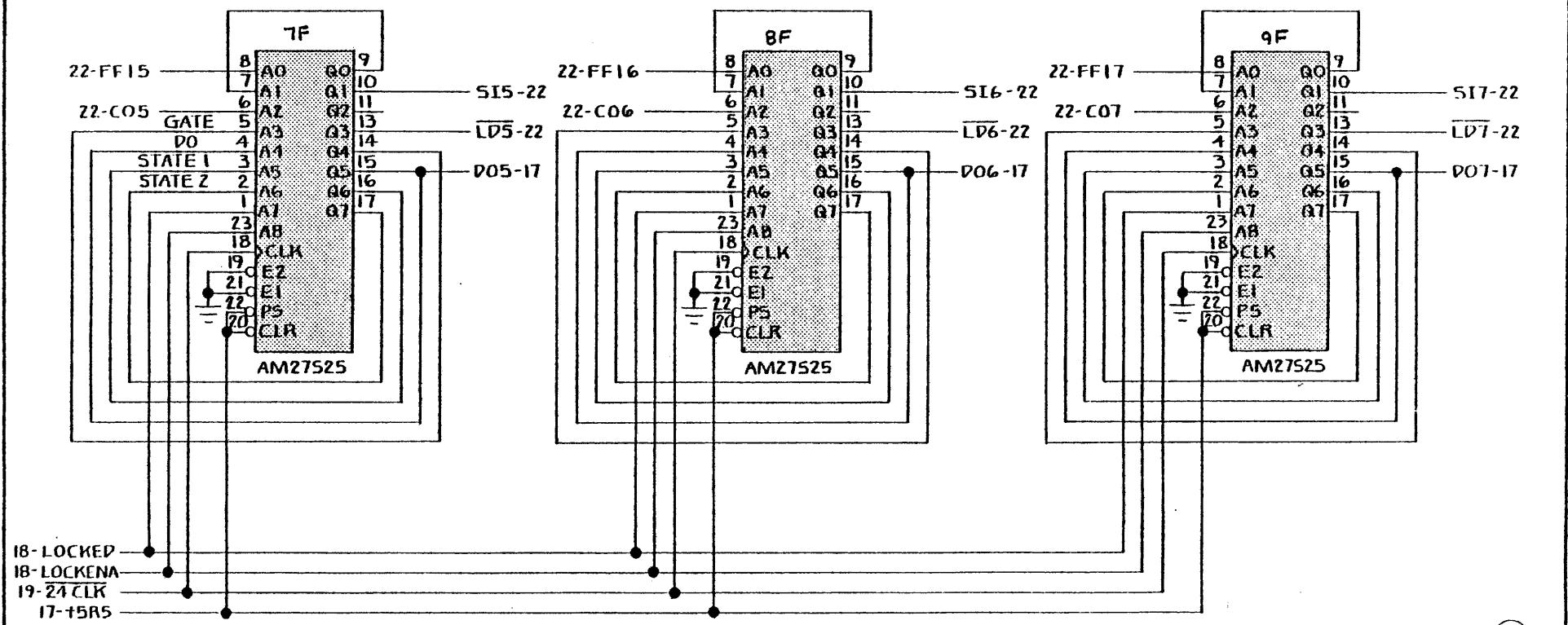

(25)

TOLERANCES UNLESS OTHERWISE SPECIFIED FRACTIONS DEC. ANGLES		 <b>western peripherals™</b> TUSTIN, CALIFORNIA	
± ± ±		PE CHNL SEQ CTRL	
APPROVALS	DATE	SCALE	SIZE DRAWING NO.
DRAWN I. FRANZKI	10-28-80		B 75000539
CHECKED H. DRZGA	11-10-80		
DO NOT SCALE DRAWING			SHEET 26 OF 27

REVISIONS			
LTR	DESCRIPTION	DATE	APPROVED

④ DEVICE ADDRESS  
STD ADDR 772520<sub>8</sub>

ADDR BIT	ADDR RANGE	E JUMPERS	STD ADDR	INSTALLED JUMPERS
17				
16				
15				
14				
13				
12				
11	0/1	28-20	0	X
10	0/1	27-19		
9	0/1	26-18	0	X
8	0/1	25-17		
7	0/1	24-16	0	X
6	0/1	23-15		
5	0/1	22-14	0	X
4	0/1	21-13		
3	X		X	
2	X		X	
1	X		X	
0	X		X	

INSTALL JUMPERS FOR "0's" IN DESIRED ADDR

OSCILLATOR JUMPERS

OPERATION	E JUMPERS
TEST FIXTURE	E73 → E75
NORMAL	E74 → E75

INTERRUPT PRIORITY LEVEL

BR4	BR5	BR6	BR7
E41 → E53	E43 → E55	E45 → E57	E47 → E59
E42 → E54	E44 → E56	E46 → E58	E48 → E60
E49 → E61	E50 → E62	E51 → E63	E52 → E64
E55 → E56	E53 → E54	E53 → E54	E53 → E54
E57 → E58	E57 → E58	E55 → E56	E55 → E56
E59 → E60	E59 → E60	E59 → E60	E57 → E58

⑤ INTERRUPT VECTOR  
STD VECTOR 224<sub>8</sub>

VCTR BIT	E JUMPERS	STD VCTR	INSTALLED JUMPERS
7	40-34		
6	39-33	0	X
5	38-32	0	X
4	37-31		
3	36-30	0	X
2	35-29		
1		0	
0		0	

INSTALL JUMPERS FOR "0's" IN DESIRED VECTOR

TOLERANCES UNLESS OTHERWISE SPECIFIED FRACTIONS DEC. ANGLES ± ± ±		 <b>western peripherals™</b> TUSTIN, CALIFORNIA	
APPROVALS DRAWN <i>C. Apada</i> CHECKED			
<b>SCHEMATIC</b> <b>TC-131 TAPE CONTROLLER</b>			
SCALE		SIZE B	DRAWING NO. 75000539
DO NOT SCALE DRAWING			SHEET 27 OF 27

REVISIONS			
LTR	DESCRIPTION	DATE	APPROVED
A	RELEASE	1-19-81	<i>[Signature]</i>
Δ	RECORD CHG P4 (2) (82)	7-17-81	<i>[Signature]</i>

CONTROL A

	H		
SLT 6	1	2	GND
SLT 7	3	4	GND
SLT 5	5	6	GND
SLT 4	7	8	GND
SLT 3	9	10	GND
SLT 0	11	12	GND
SLT 1	13	14	GND
SLT 2	15	16	GND
FLPT	17	18	GND
WNB	19	20	GND
OVW	21	22	GND
ASL	23	24	GND
EOTP	25	26	GND
RWC	27	28	GND
VSL	29	30	GND
BOIP	31	32	GND
FSL	33	34	GND
+5V	35	36	GND
+5V	37	38	GND
RWG	39	40	GND
TRDY	41	42	GND
ONL	43	44	GND
	45	46	GND
SPD	47	48	GND
NRZ	49	50	GND

WRITE B1

	J		
WDS	1	2	GND
WD7	3	4	GND
WARS	5	6	GND
WDS	7	8	GND
	9	10	GND
WD5	11	12	GND
WDP	13	14	GND
WD4	15	16	GND
WDO	17	18	GND
WD3	19	20	GND
WD1	21	22	GND
WD2	23	24	GND
+5V	25	26	GND

READ B2

	K		
RD7	1	2	GND
RD6	3	4	GND
RD5	5	6	GND
RD4	7	8	GND
RD3	9	10	GND
RD2	11	12	GND
RD1	13	14	GND
NRZ	15	16	GND
	17	18	GND
RDO	19	20	GND
RDS	21	22	GND
RDP	23	24	GND
	25	26	GND

7 SPEED SETTING

SW POS	125	125	125	125	75	75	75	45	45	375	SELB
628	75	15	375	25	45	375	25	375	25	25	SELA
1	C	C	C	C	C	C	C	O	O	O	
2	C	C	C	C	O	O	O	C	C	O	
3	C	C	O	O	C	O	O	C	O	C	
4	C	O	C	O	O	C	O	O	C	C	

C = ON  
O = OFF

TAPE CTRL CBL NRZ SWA-4

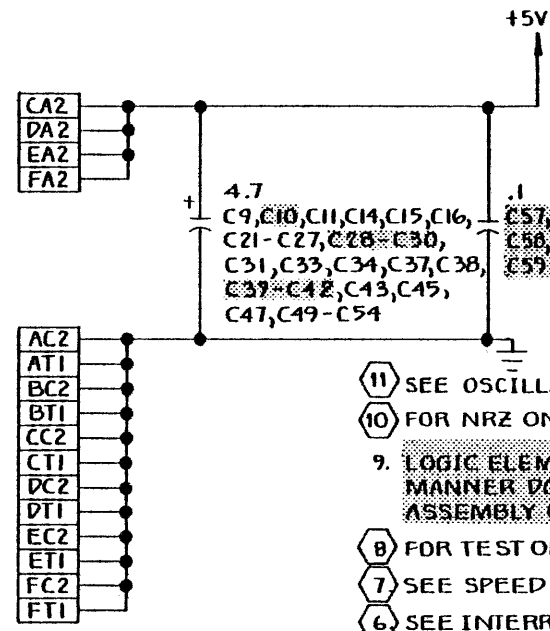

LAST DESIGNATION USEV	
RESISTOR	R65
CAPACITOR	C60
DIODE	CR8
OSCILLATOR	Y2
LIGHT EMITTING DIODE	LED5
RESISTOR NETWORK	RN5

- 11 SEE OSCILLATOR JUMPER TABLE.
  - 10 FOR NRZ ONLY OPERATION.
  - 9 LOGIC ELEMENTS SHADED IN THIS MANNER DO NOT EXIST ON THE TC-131N ASSEMBLY 60000890 (NRZ ONLY).
  - 8 FOR TEST ONLY
  - 7 SEE SPEED SETTING TABLE.
  - 6 SEE INTERRUPT PRIORITY LEVEL TABLE.
  - 5 SEE INTERRUPT VECTOR TABLE.
  - 4 SEE DEVICE ADDRESS TABLE
  - 3. REFERENCE ASSY 60000841
  - 2. CAPACITOR VALUES ARE IN MICROFARADS.
  - 1. RESISTANCE VALUES ARE IN OHMS.
- NOTES: UNLESS OTHERWISE SPECIFIED

TOLERANCES UNLESS OTHERWISE SPECIFIED		 western peripherals™ TUSTIN, CALIFORNIA	
FRACTIONS DEC. ANGLES		<p style="text-align: center;">SCHEMATIC TC-131 TAPE CONTROLLER</p>	
±	±	±	
APPROVALS	DATE	SCALE	SIZE DRAWING NO.
DRAWN L. FRANZKE	10-28-80		B 75000752
CHECKED HD	11-10-80		
	11-10-80		
DO NOT SCALE DRAWING			SHEET 1 OF 27

REVISIONS			
LTR	DESCRIPTION	DATE	APPROVED

IBM PACK	REMOTE DENSITY SELECT
1. STANDARD - Bit 10 in MTRD	1. STANDARD - Drive Density Switch
2. OPTION 1 - Use of Drive Select- Bit 10 in MTC	2. OPTION 1 - Use of Drive Select- Bit 10 in MTC
3. OPTION 2 - Customer installed jumper or remote switch	

When using OPTION 1 either IBM Pack OR Remote Density Select can be opted, NOT both. In order for a customer to have both options, the following are the different combinations.

IBM PACK	REMOTE DENSITY SELECT
1. Standard	Standard and/or Option 1
2. Option 1	Standard
3. Option 2	Standard and/or Option 1

IBM PACK	REMOTE DENSITY SELECT	JUMPERS
Standard	Standard	E82 to E83, E84 to E85
Standard	Option 1	E83 to E85, E82 to E84
Option 1	Standard	E83 to E85, E84 to E85, E80 to E81
Option 2	Standard	E82 to E83, E84 to E85, E78 to E79
Option 2	Option 1	E83 to E85, E82 to E84, E78 to E79

TOLERANCES UNLESS OTHERWISE SPECIFIED FRACTIONS DEC ANGLES ± ± ±		 <b>western peripherals™</b> TUSTIN, CALIFORNIA	
APPROVALS			
DRAWN		6-17-81	
CHECKED		SCALE	SIZE
			<b>B</b>
		DRAWING NO.	
		75000752	
DO NOT SCALE DRAWING			SHEET 1A-27

REVISIONS			
LTR	DESCRIPTION	DATE	APPROVED

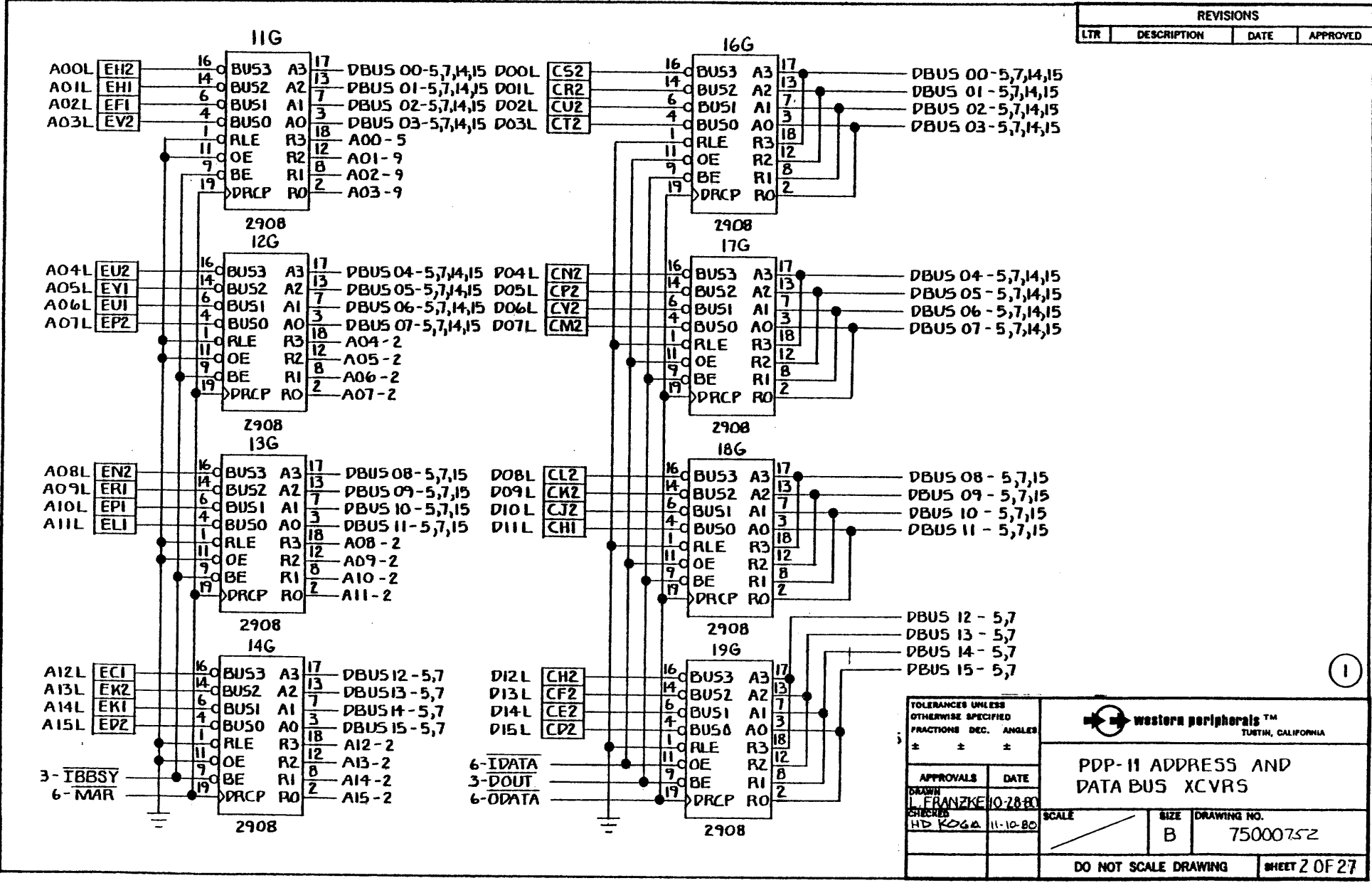

TOLERANCES UNLESS OTHERWISE SPECIFIED		 western peripherals™ TUSTIN, CALIFORNIA	
FRACTIONS DEC.	ANGLES		
±	±	PDP-11 ADDRESS AND DATA BUS XCVRS	
APPROVALS	DATE	SCALE	SIZE
DRAWN L. FRANZKE	10-28-80		B
CHECKED HD KOGA	11-10-80	DRAWING NO. 75000752	
DO NOT SCALE DRAWING			SHEET 2 OF 27

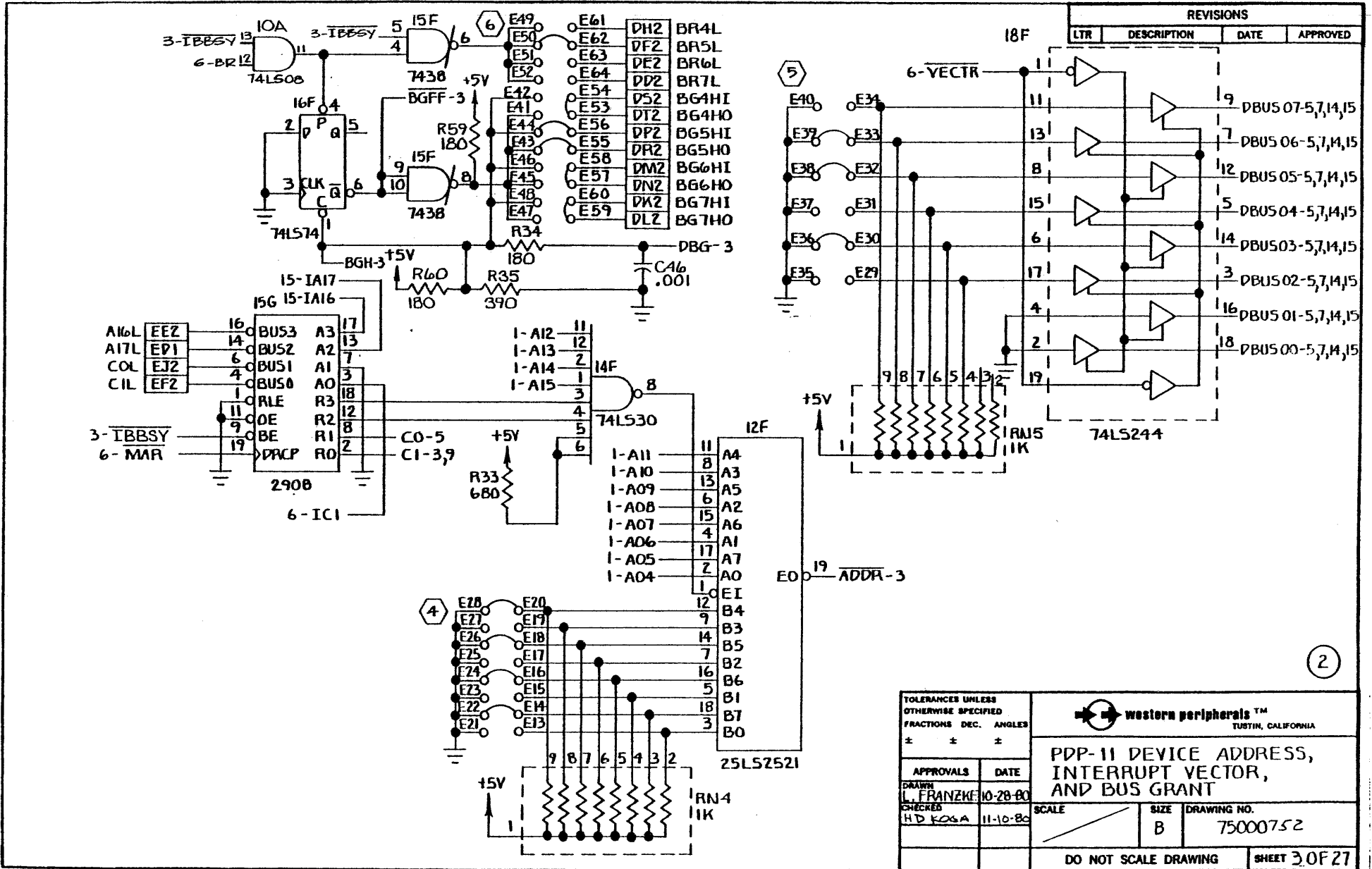

2

TOLERANCES UNLESS OTHERWISE SPECIFIED FRACTIONS DEC. ANGLES ± ± ±		<b>western peripherals™</b> TUSTIN, CALIFORNIA	
APPROVALS DRAWN L. FRANZKE CHECKED H.D. KOSA		DATE 10-28-80 11-10-80	
SCALE		SIZE B	DRAWING NO. 75000752
DO NOT SCALE DRAWING			SHEET 3 OF 27

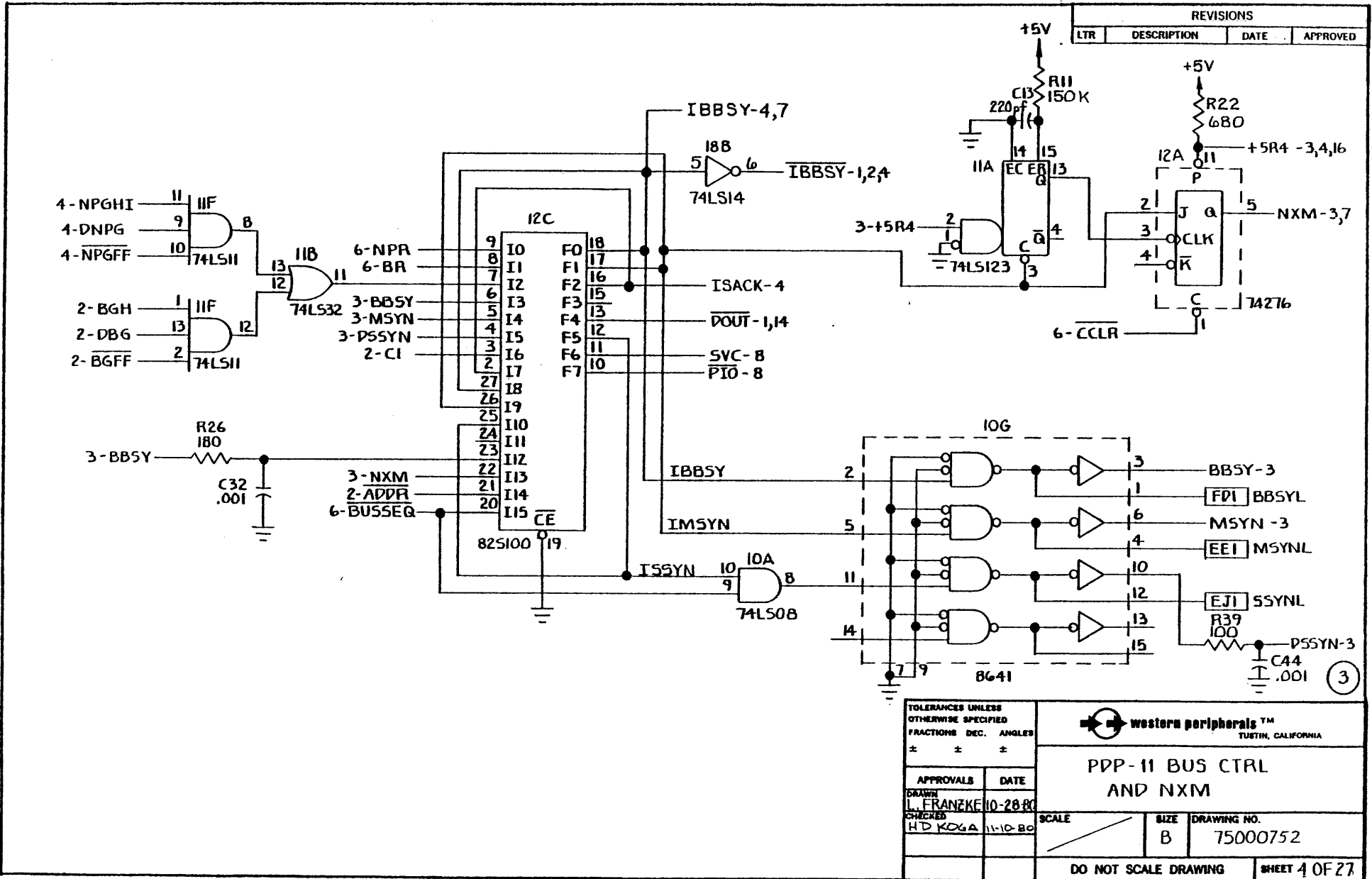

REVISIONS			
LTR	DESCRIPTION	DATE	APPROVED

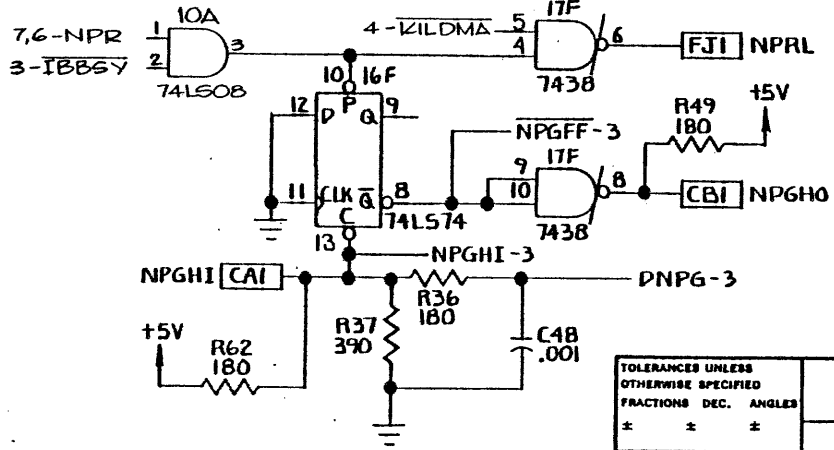
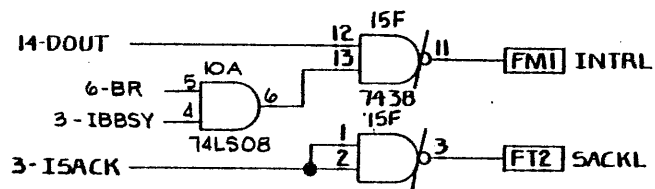
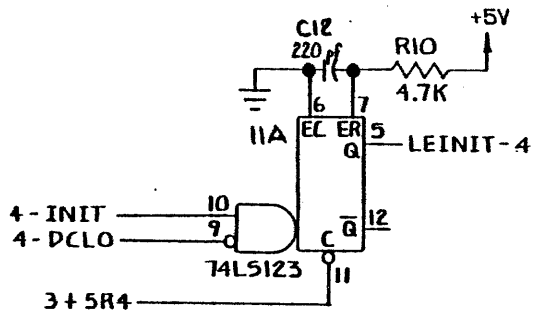
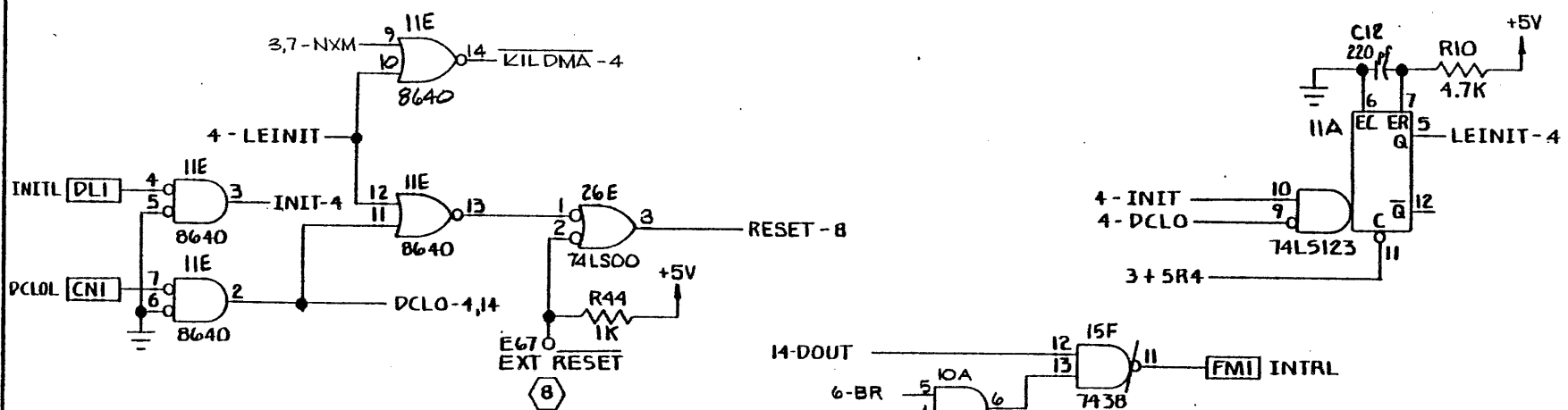

4

TOLERANCES UNLESS OTHERWISE SPECIFIED FRACTIONS DEC. ANGLES ± ± ±		western peripherals™ TUSTIN, CALIFORNIA	
PDP-11 INIT, DCLO, AND NPR GRANT			
APPROVALS DRAWN L. FRANZKE	DATE 10-28-80	SCALE	SIZE B
CHECKED H.D. KOEHLER	DATE 11-10-80	DRAWING NO. 75000752	
DO NOT SCALE DRAWING			SHEET 5 OF 27



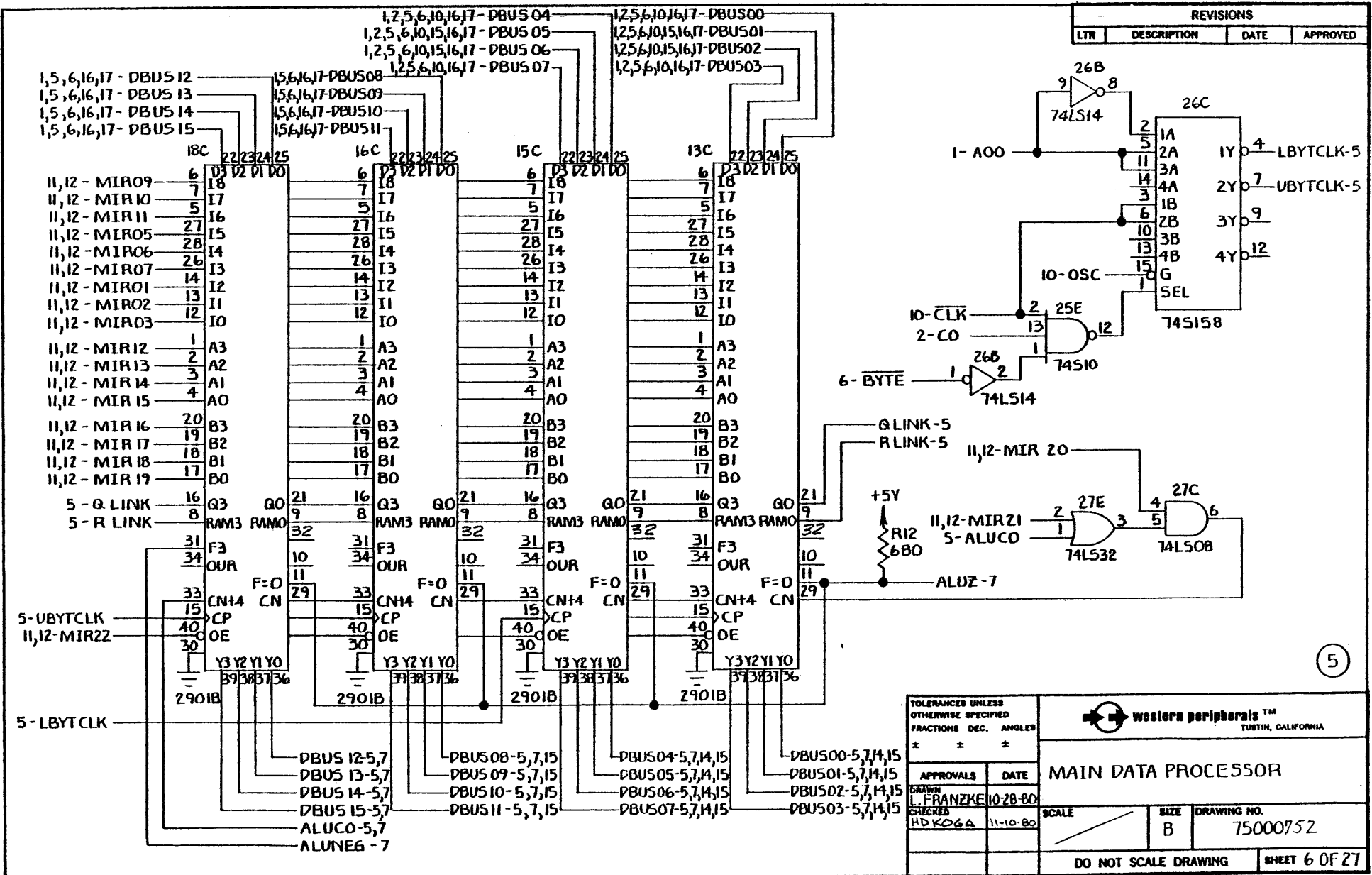

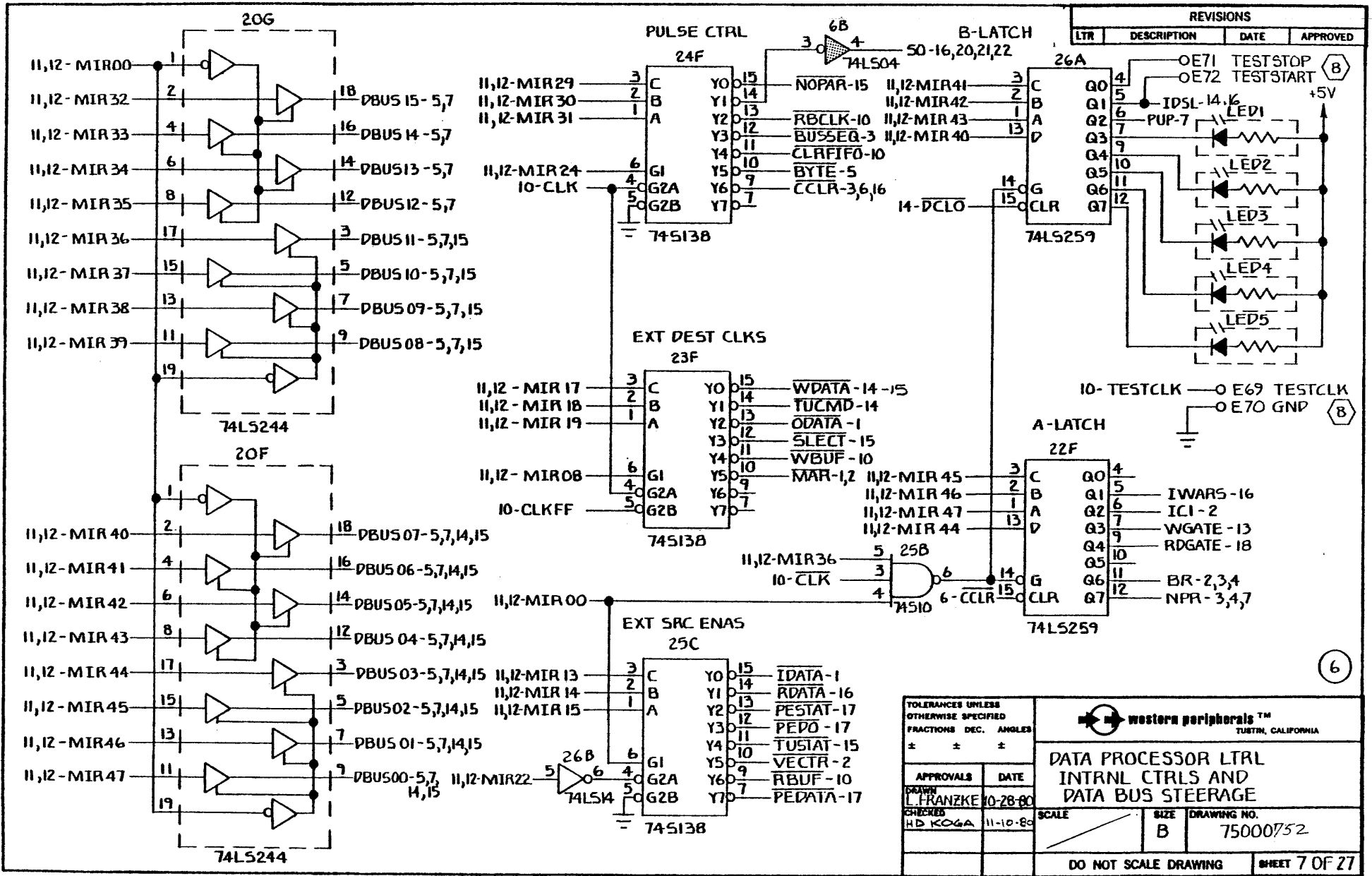

6

TOLERANCES UNLESS OTHERWISE SPECIFIED  
FRACTIONS DEC. ANGLES  
± ± ±

**western peripherals™**  
TUSTIN, CALIFORNIA

**DATA PROCESSOR LTRL  
INTRNL CTRLS AND  
DATA BUS STEERAGE**

APPROVALS	DATE	SCALE	SIZE	DRAWING NO.
DRAWN L. FRANZKE	10-28-80			
CHECKED HD KOGA	11-10-80	DO NOT SCALE DRAWING		SHEET 7 OF 27

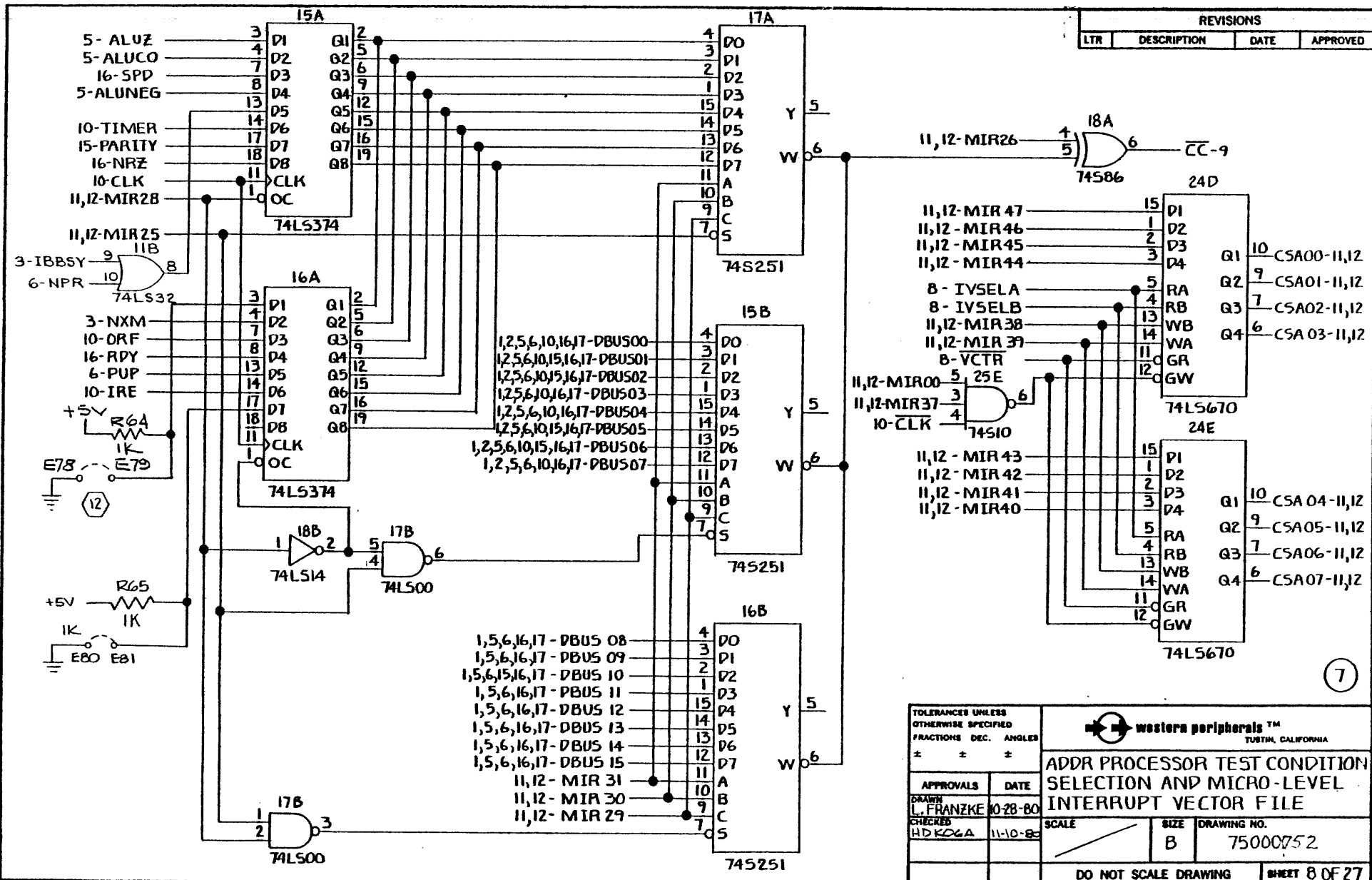

REVISIONS			
LTR	DESCRIPTION	DATE	APPROVED

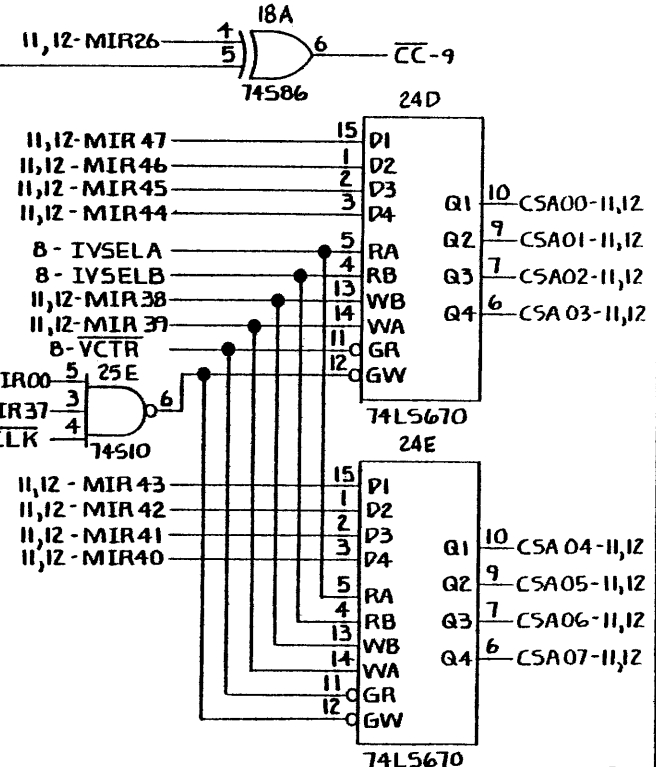

TOLERANCES UNLESS OTHERWISE SPECIFIED		 western peripherals™ TUSTIN, CALIFORNIA	
FRACTIONS	DEC.		
±	±	±	<b>ADDR PROCESSOR TEST CONDITION SELECTION AND MICRO-LEVEL INTERRUPT VECTOR FILE</b>
APPROVALS	DATE	SCALE	
DRAWN L. FRANZKE	10-28-80	SIZE B	
CHECKED HD KOGA	11-10-80	DRAWING NO. 75000752	
DO NOT SCALE DRAWING			SHEET 8 OF 27

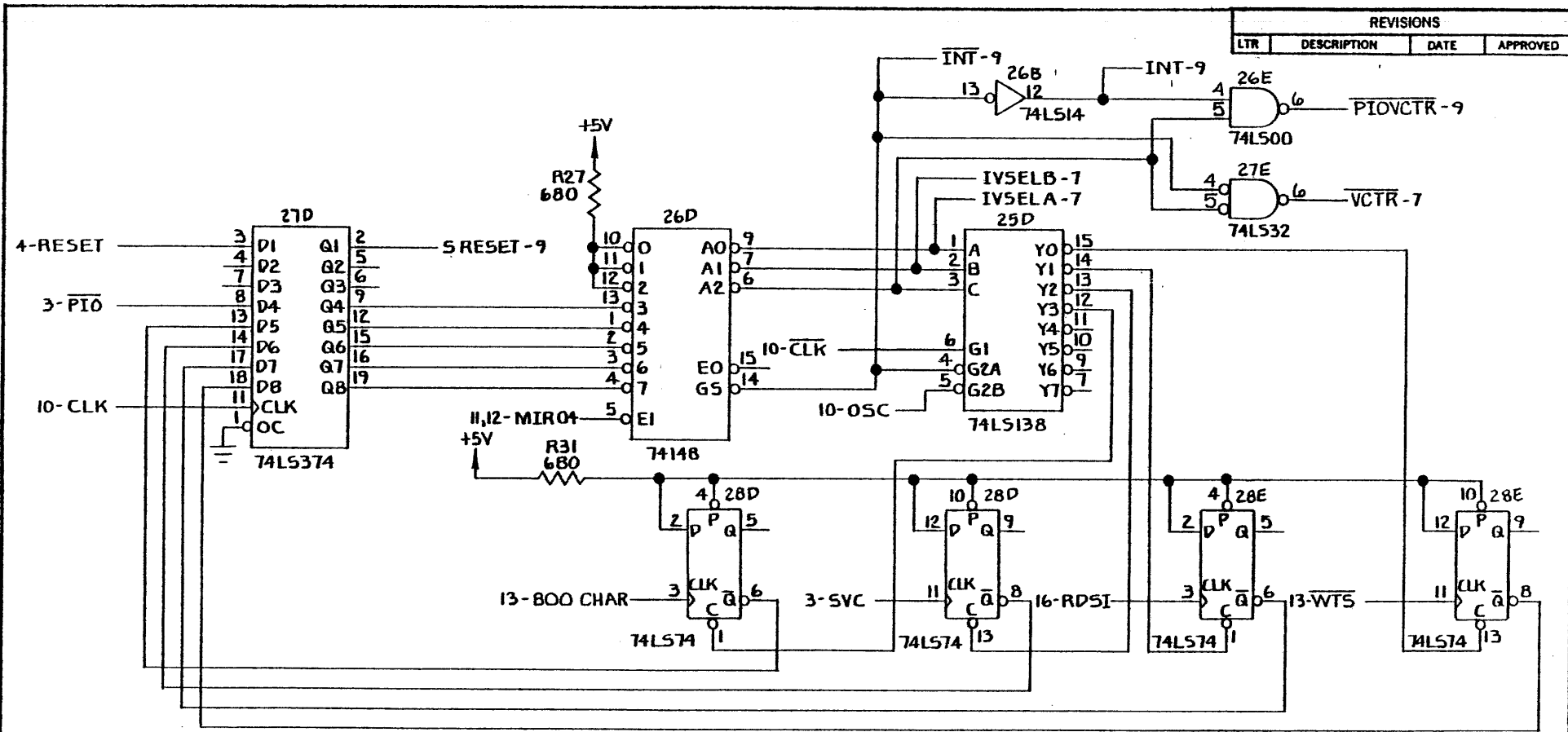

REVISIONS			
LTR	DESCRIPTION	DATE	APPROVED

(B)

TOLERANCES UNLESS OTHERWISE SPECIFIED		western peripherals™ TUSTIN, CALIFORNIA	
FRACTIONS DEC.	ANGLES		
±	±	MICRO-LEVEL INTERRUPT CTRL	
APPROVALS	DATE	SCALE	SIZE
DRAWN L. FRANZKE	10-28-80	/	B
CHECKED HD KOGA	11-10-80		
DRAWING NO. 75000752		DO NOT SCALE DRAWING	
SHEET 9 OF 27			

REVISIONS			
LTR	DESCRIPTION	DATE	APPROVED

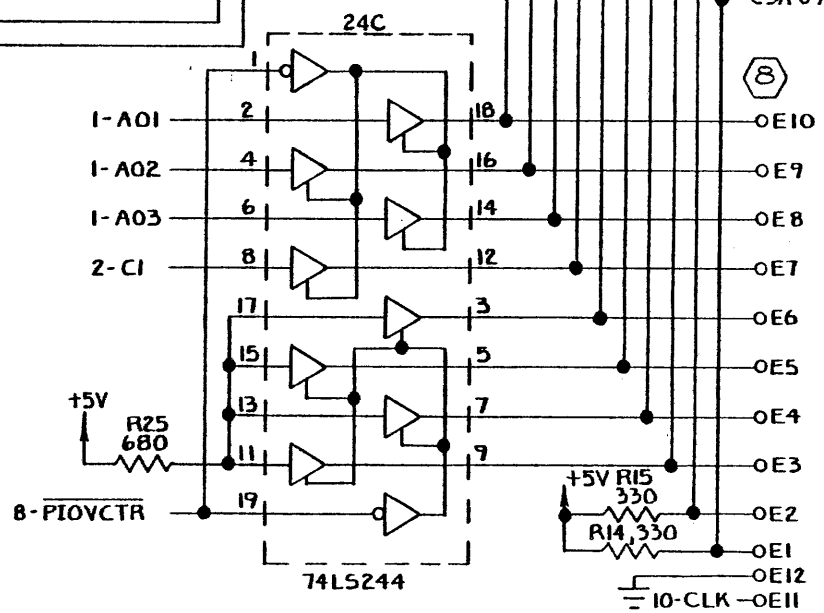
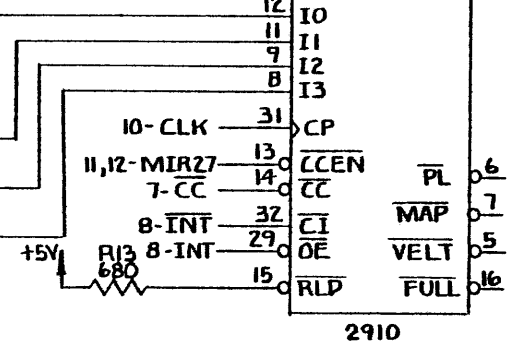
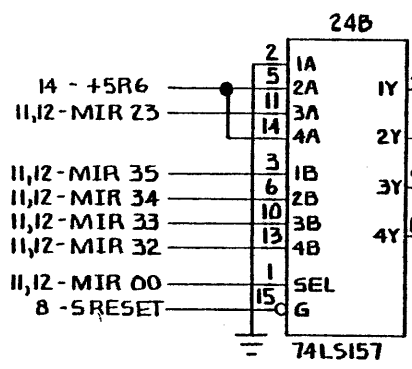
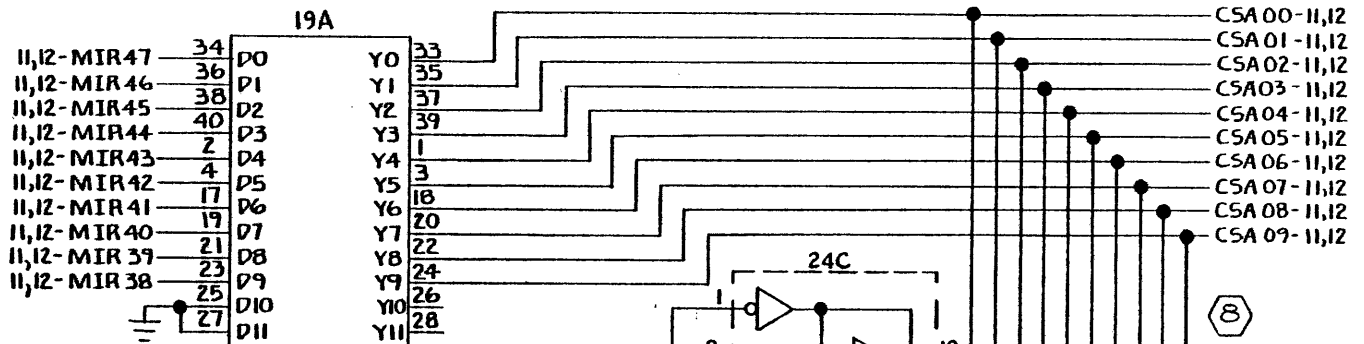

8

9

TOLERANCES UNLESS OTHERWISE SPECIFIED		western peripherals™ TUSTIN, CALIFORNIA	
FRACTIONS DEC. ANGLES	± ± ±		
APPROVALS		DATE	
DRAWN L. FRANZKE		10-28-80	
CHECKED H.D. KOGA		11-10-80	
SCALE		SIZE B	DRAWING NO. 75000752
DO NOT SCALE DRAWING			SHEET 10 OF 27

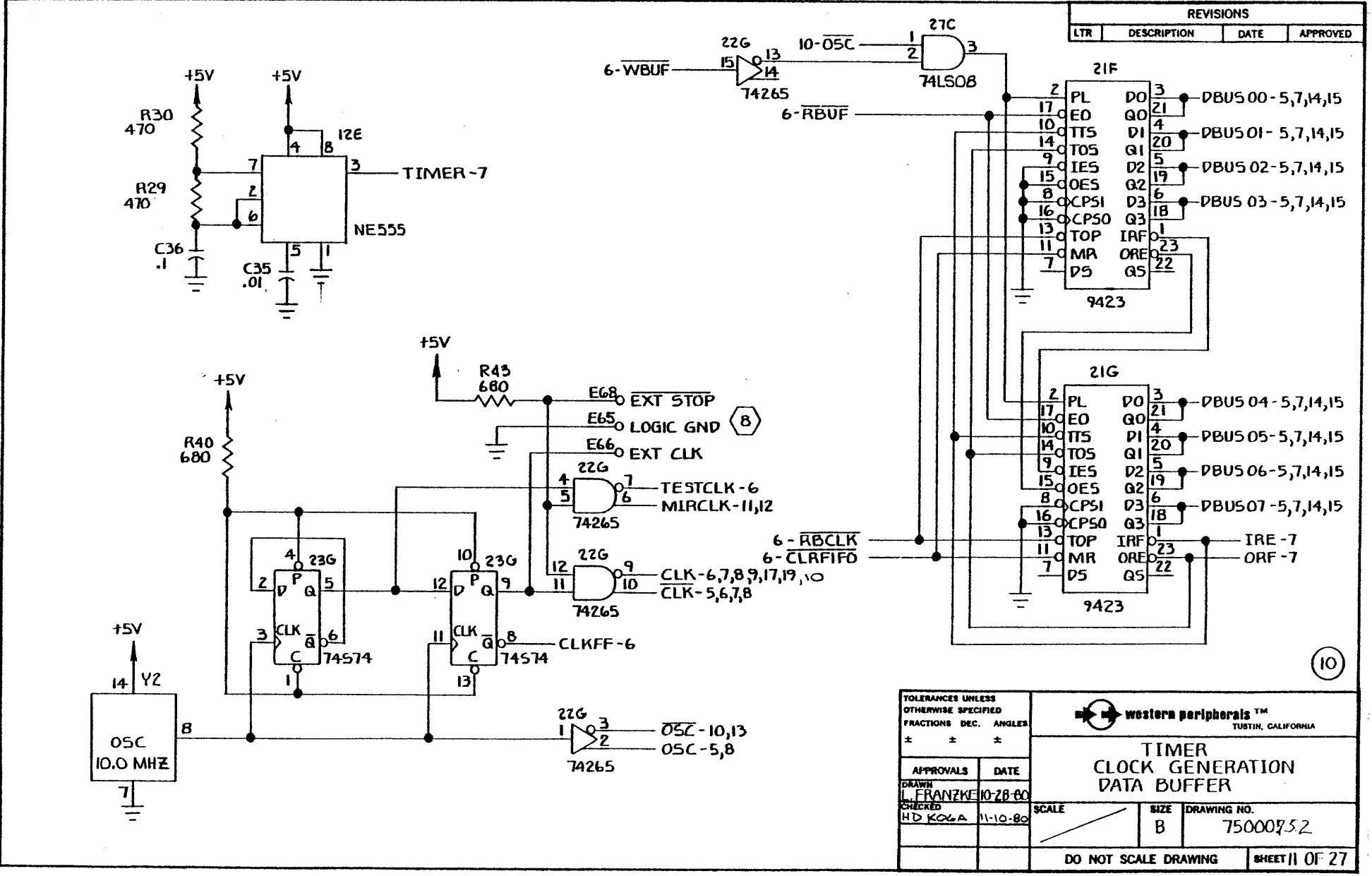

REVISIONS			
LTR	DESCRIPTION	DATE	APPROVED

(10)

TOLERANCES UNLESS OTHERWISE SPECIFIED		 western peripherals™ TUSTIN, CALIFORNIA	
FRACTIONS DEC.	ANGLES		
±	±		
APPROVALS	DATE	<b>TIMER CLOCK GENERATION DATA BUFFER</b>	
DRAWN L. FRANZKE	10-28-80		
CHECKED HD KOGA	11-10-80		
SCALE		SIZE B	DRAWING NO. 75000752
DO NOT SCALE DRAWING		SHEET 11 OF 27	

REVISIONS			
LTR	DESCRIPTION	DATE	APPROVED

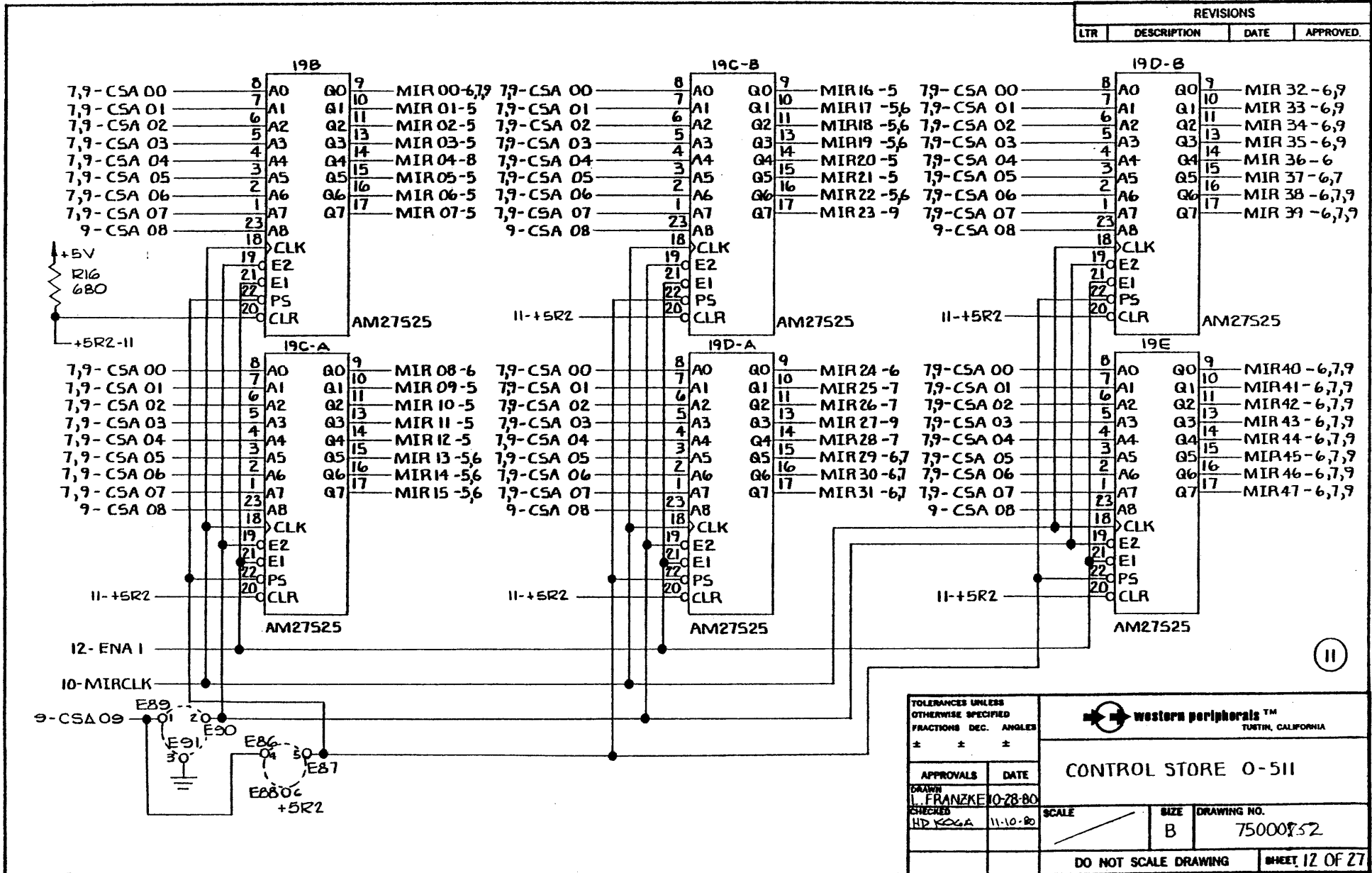

TOLERANCES UNLESS OTHERWISE SPECIFIED		 western peripherals™ TUSTIN, CALIFORNIA		
FRACTIONS DEC.	ANGLES			
±	±	<b>CONTROL STORE 0-511</b>		
APPROVALS	DATE			
DRAWN L. FRANZKE	10-28-80	SCALE	SIZE B	DRAWING NO. 75000852
CHECKED HD YCGA	11-10-80	DO NOT SCALE DRAWING		SHEET 12 OF 27

REVISIONS			
LTR	DESCRIPTION	DATE	APPROVED

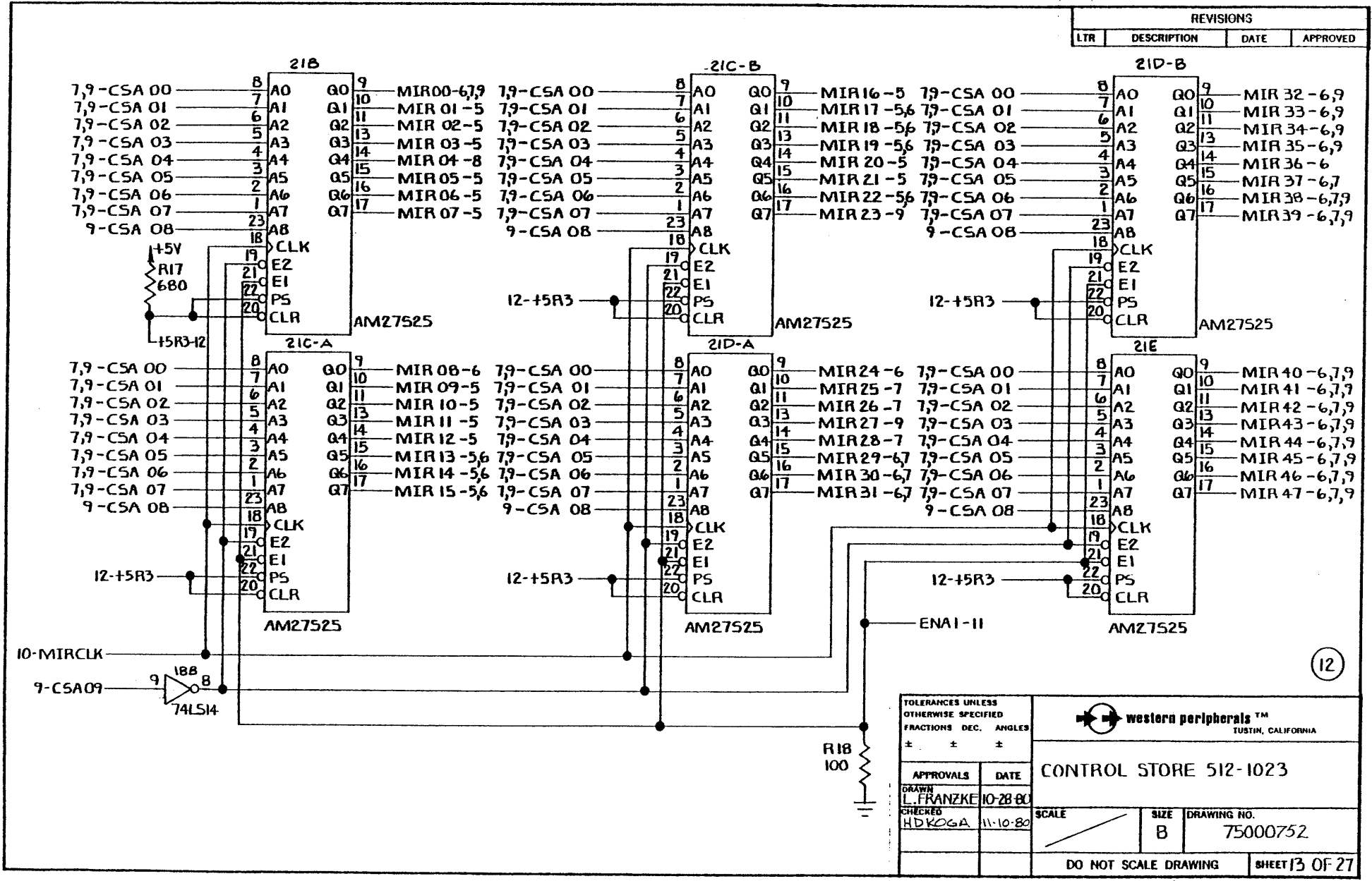

12

TOLERANCES UNLESS OTHERWISE SPECIFIED			 western peripherals™ TUSTIN, CALIFORNIA	
FRACTIONS	DEC.	ANGLES		
±	±	±	CONTROL STORE 512-1023	
APPROVALS	DATE	SCALE		
DRAWN L. FRANZKE	10-28-80		SIZE B	DRAWING NO. 75000752
CHECKED HDKOGA	11-10-80		DO NOT SCALE DRAWING	
			SHEET 13 OF 27	



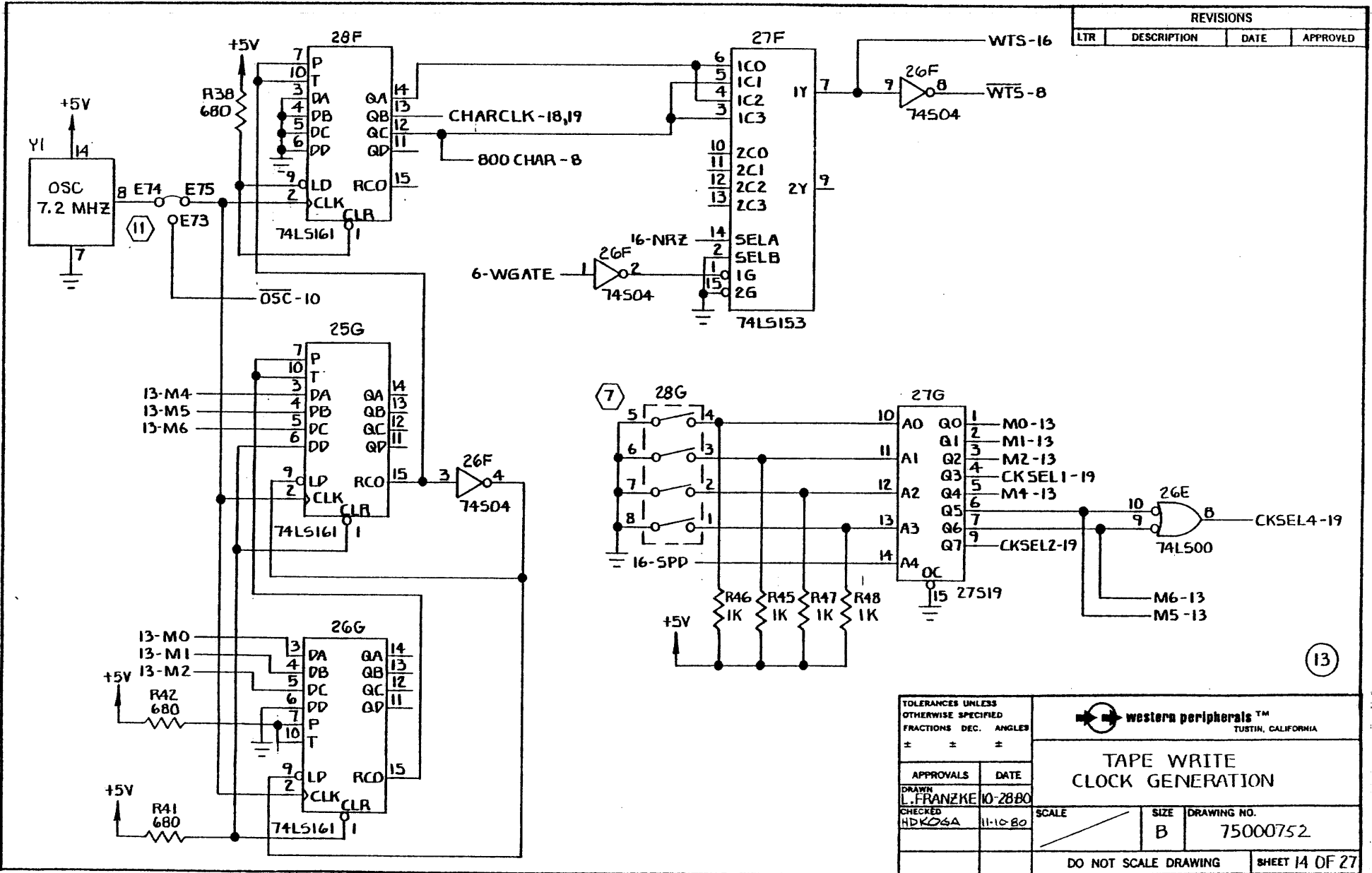

REVISIONS			
LTR	DESCRIPTION	DATE	APPROVED

TOLERANCES UNLESS OTHERWISE SPECIFIED FRACTIONS DEC. ANGLES ± ± ±		 western peripherals™ TUSTIN, CALIFORNIA	
APPROVALS			
DRAWN L. FRANZKE		10-28-80	<b>TAPE WRITE CLOCK GENERATION</b>
CHECKED HDK/64A		11-10-80	
SCALE		SIZE B	DRAWING NO. 75000752
DO NOT SCALE DRAWING			SHEET 14 OF 27

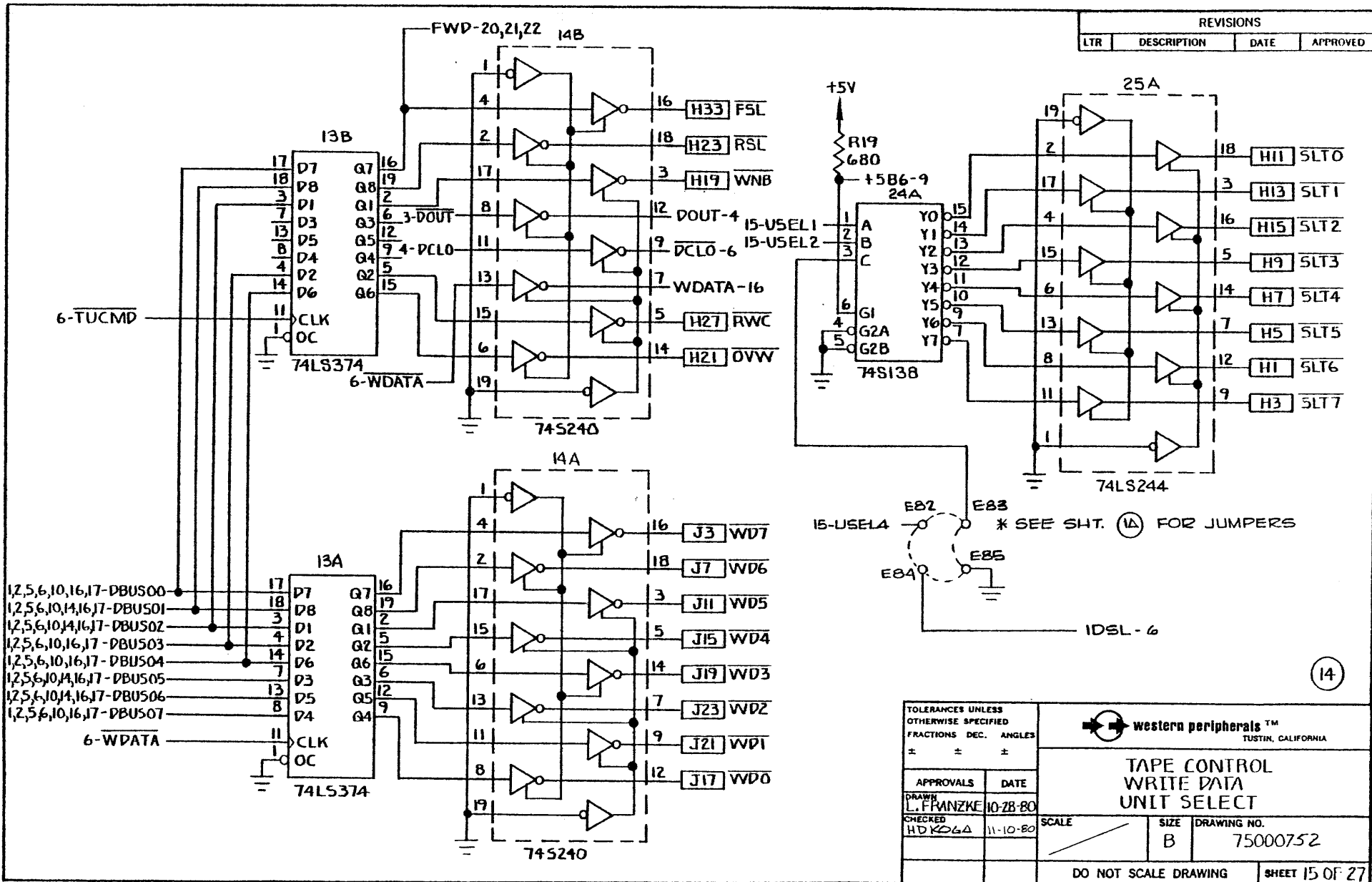

REVISIONS			
LTR	DESCRIPTION	DATE	APPROVED

(14)

TOLERANCES UNLESS OTHERWISE SPECIFIED FRACTIONS DEC. ANGLES ± ± ±		 western peripherals™ TUSTIN, CALIFORNIA	
APPROVALS		DATE	
DRAWN L. FRANZKE		10-28-80	
CHECKED HDK/DA		11-10-80	
SCALE		SIZE B	DRAWING NO. 75000752
DO NOT SCALE DRAWING			SHEET 15 OF 27

REVISIONS			
LTR	DESCRIPTION	DATE	APPROVED

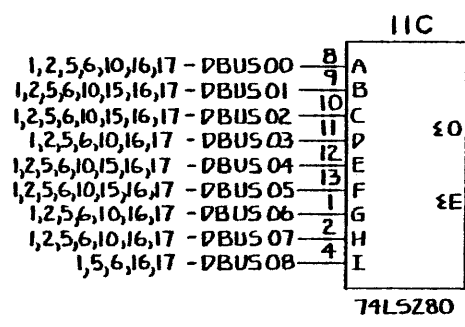
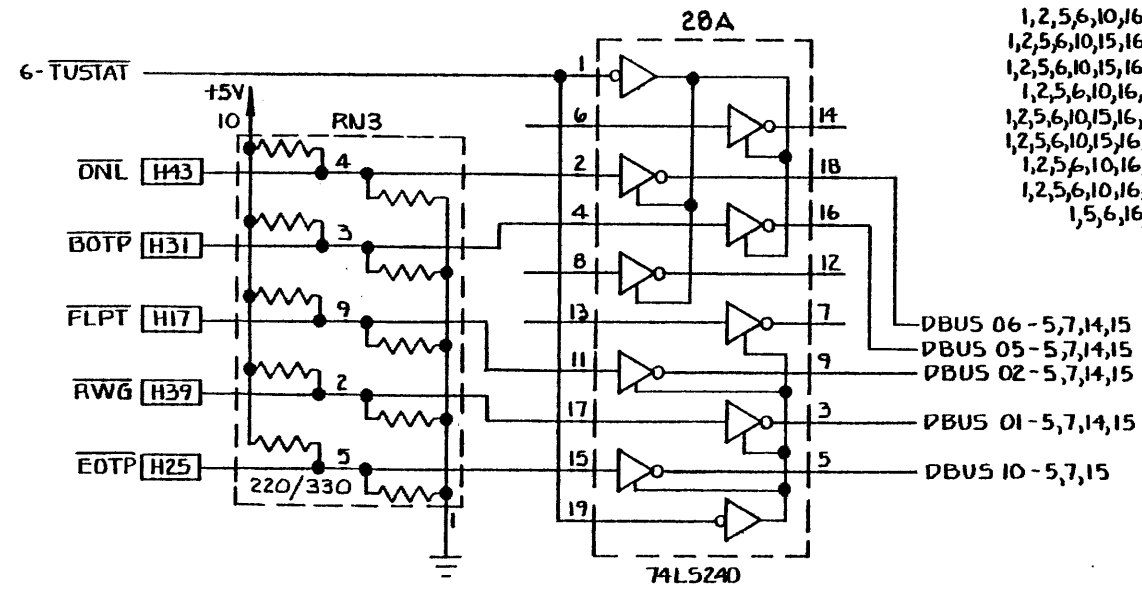
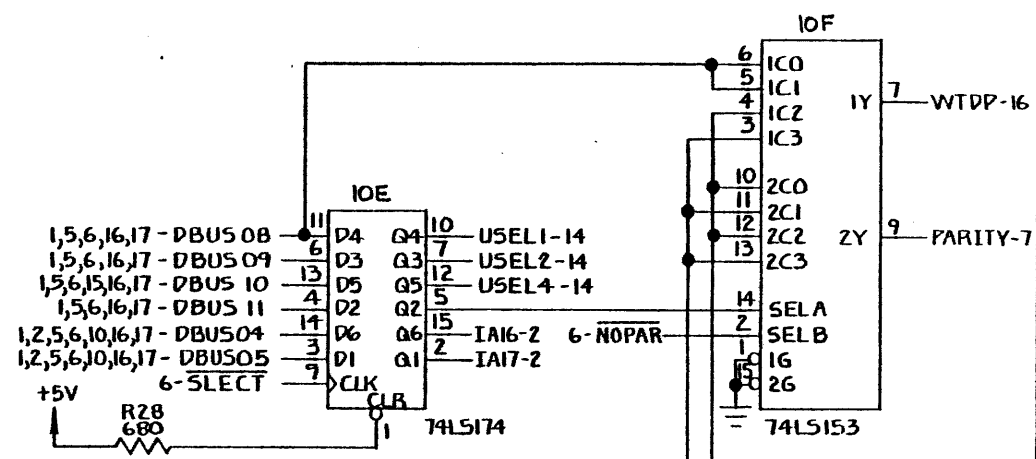

15

TOLERANCES UNLESS OTHERWISE SPECIFIED FRACTIONS DEC. ANGLES ± ± ±		 western peripherals™ TUSTIN, CALIFORNIA	
APPROVALS		DATE	
DRAWN L. FRANZKE		10-28-80	
CHECKED H.D. KOGA		11-10-80	
SCALE		SIZE B	DRAWING NO. 75000752
DO NOT SCALE DRAWING			SHEET 16 OF 27

REVISIONS			
LTR	DESCRIPTION	DATE	APPROVED

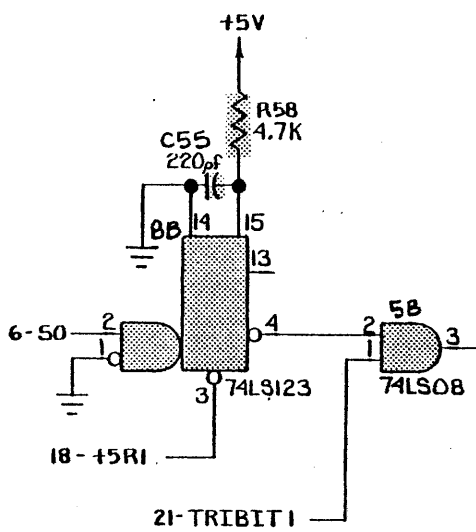
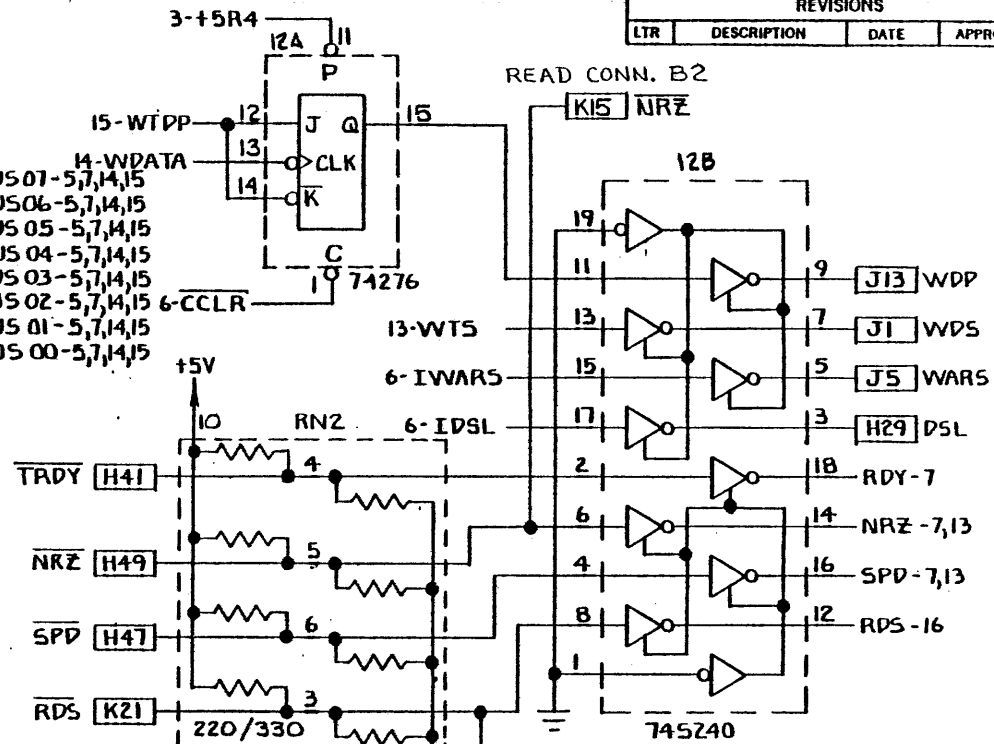
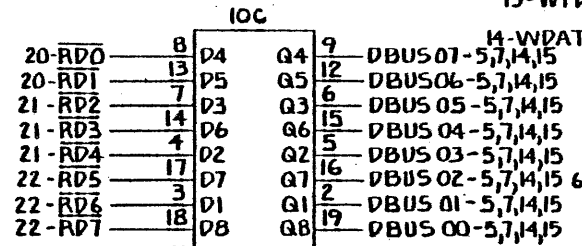

TOLERANCES UNLESS OTHERWISE SPECIFIED		 <b>western peripherals™</b> TUSTIN, CALIFORNIA	
FRACTIONS DEC. ANGLES		<b>TAPE CONTROL AND STATUS READ DATA</b>	
±	±	±	±
APPROVALS	DATE	SCALE	SIZE
DRAWN L. FRANZKE	10-28-80		B
CHECKED HD KOGA	11-10-80	DRAWING NO. 75000752	
DO NOT SCALE DRAWING			SHEET 17 OF 27

16

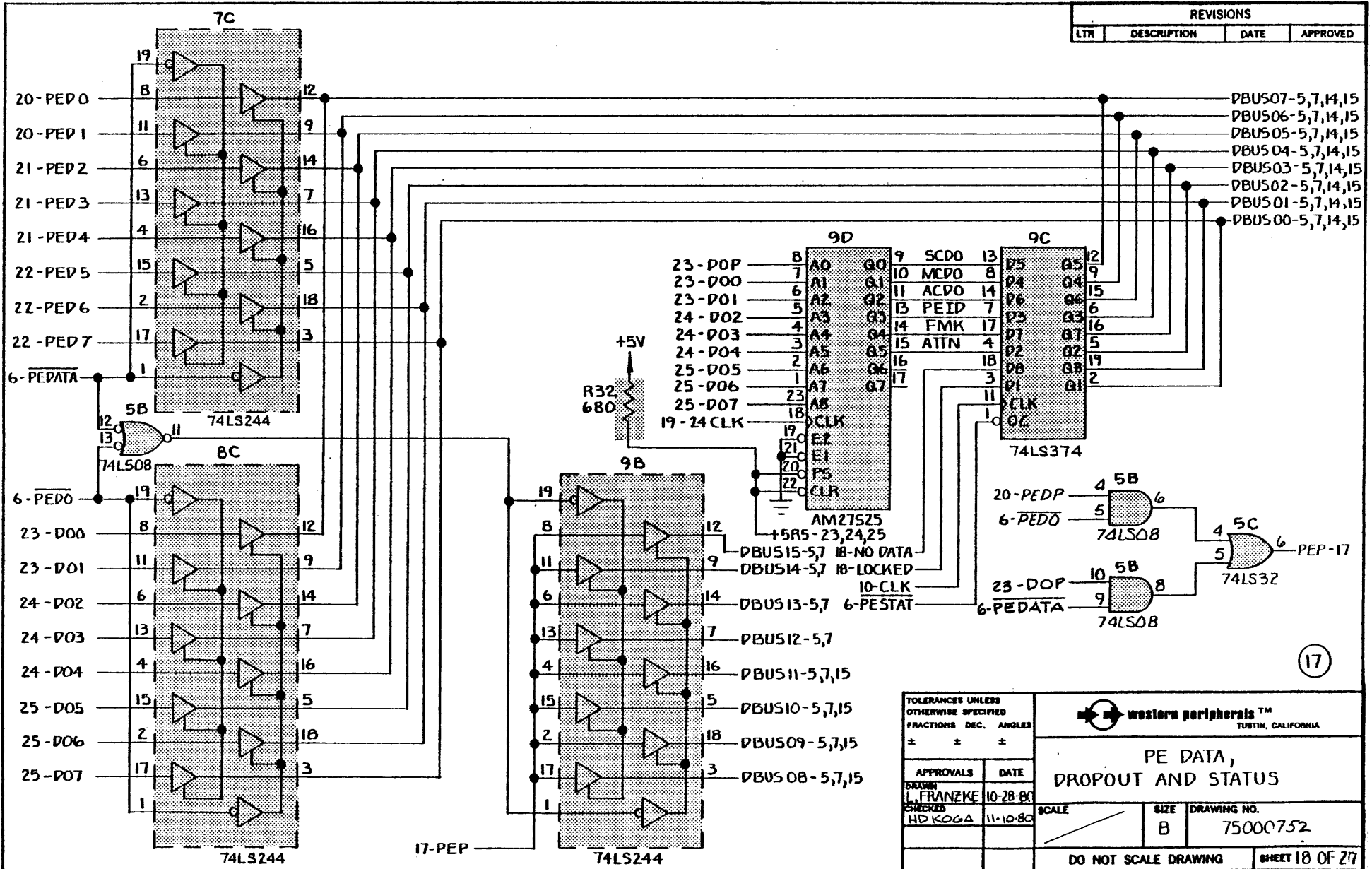

(17)

TOLERANCES UNLESS OTHERWISE SPECIFIED FRACTIONS DEC. ANGLES ± ± ±		 western peripherals™ TUSTIN, CALIFORNIA	
APPROVALS L. FRANZKE CHECKED HD KOGA		DATE 10-28-80 11-10-80	
SCALE		SIZE B	DRAWING NO. 75000752
DO NOT SCALE DRAWING		SHEET 18 OF 27	

REVISIONS			
LTR	DESCRIPTION	DATE	APPROVED

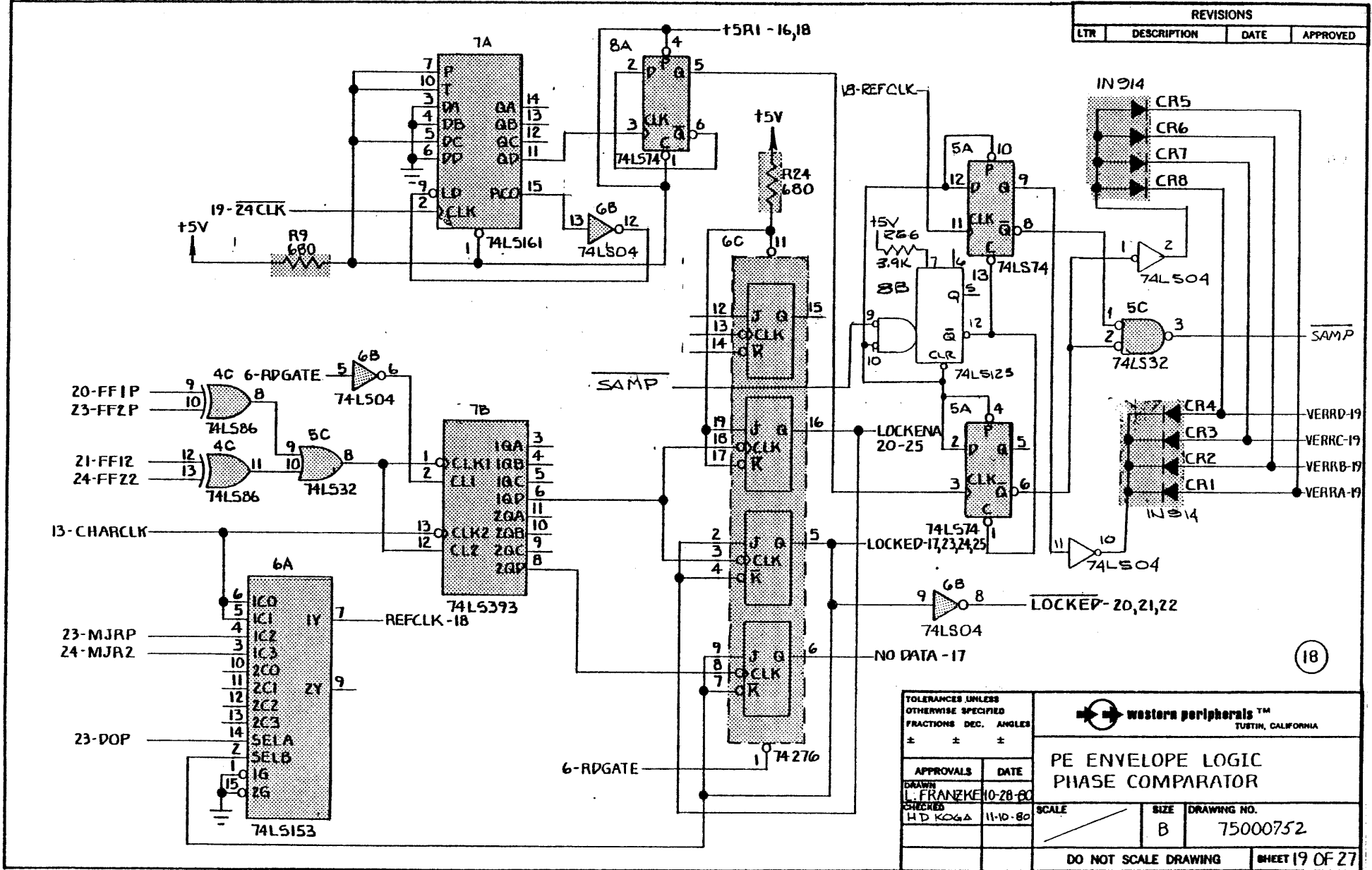

(18)

TOLERANCES UNLESS OTHERWISE SPECIFIED FRACTIONS DEC. ANGLES ± ± ±		 western peripherals™ TUSTIN, CALIFORNIA	
APPROVALS DRAWN L. FRANZKE 10-28-80 CHECKED H.D. KOGA 11-10-80		DATE SCALE SIZE B DRAWING NO. 75000752	
DO NOT SCALE DRAWING		SHEET 19 OF 27	

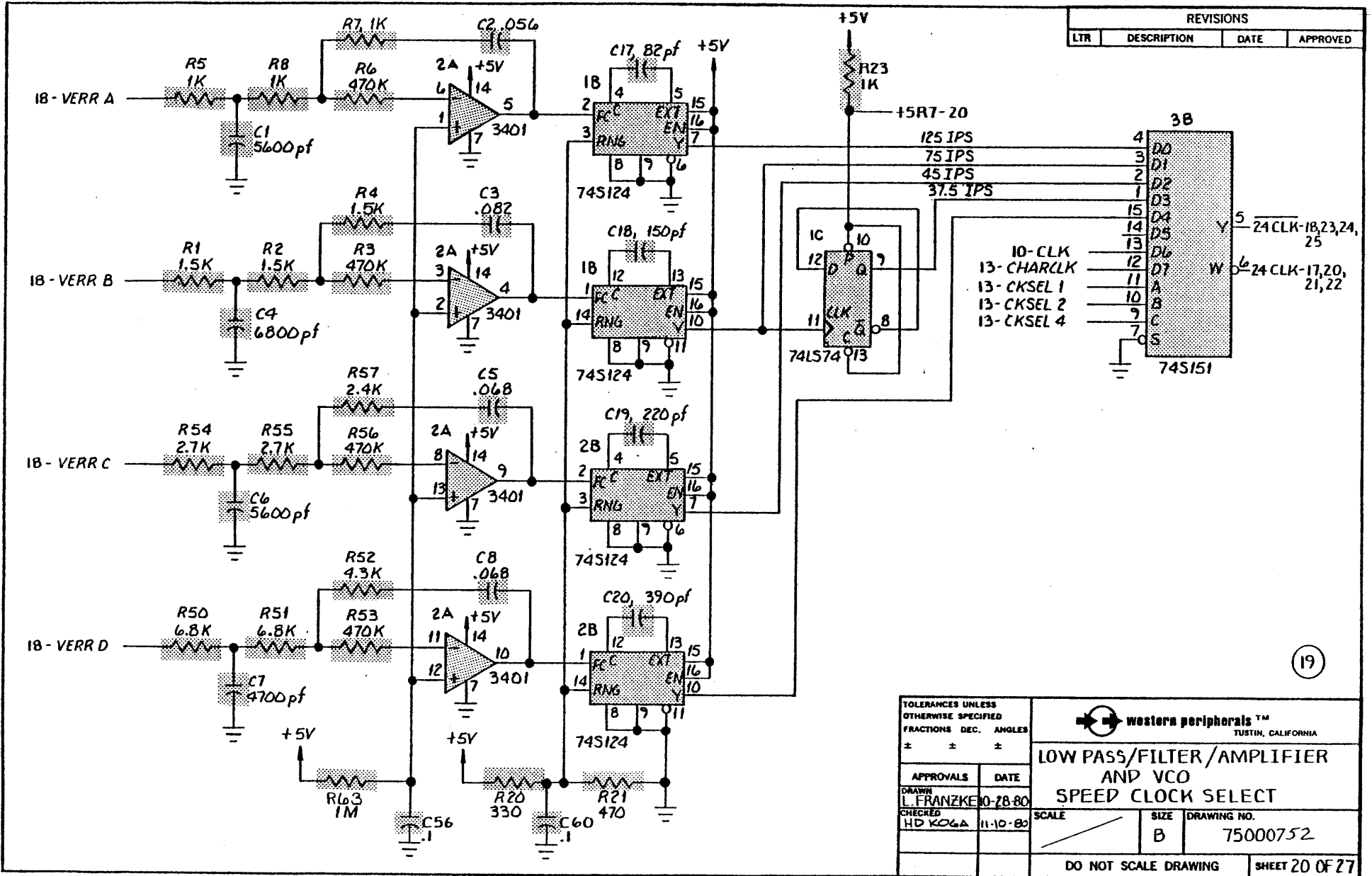

REVISIONS			
LTR	DESCRIPTION	DATE	APPROVED

(19)

TOLERANCES UNLESS OTHERWISE SPECIFIED		western peripherals™ TUSTIN, CALIFORNIA	
FRACTIONS DEC. ANGLES			
±	±	<b>LOW PASS/FILTER/AMPLIFIER AND VCO SPEED CLOCK SELECT</b>	
APPROVALS	DATE	SCALE	SIZE
DRAWN L. FRANZKE	10-28-80		B
CHECKED HD KOZA	11-10-80		DRAWING NO. 75000752
DO NOT SCALE DRAWING			SHEET 20 OF 27

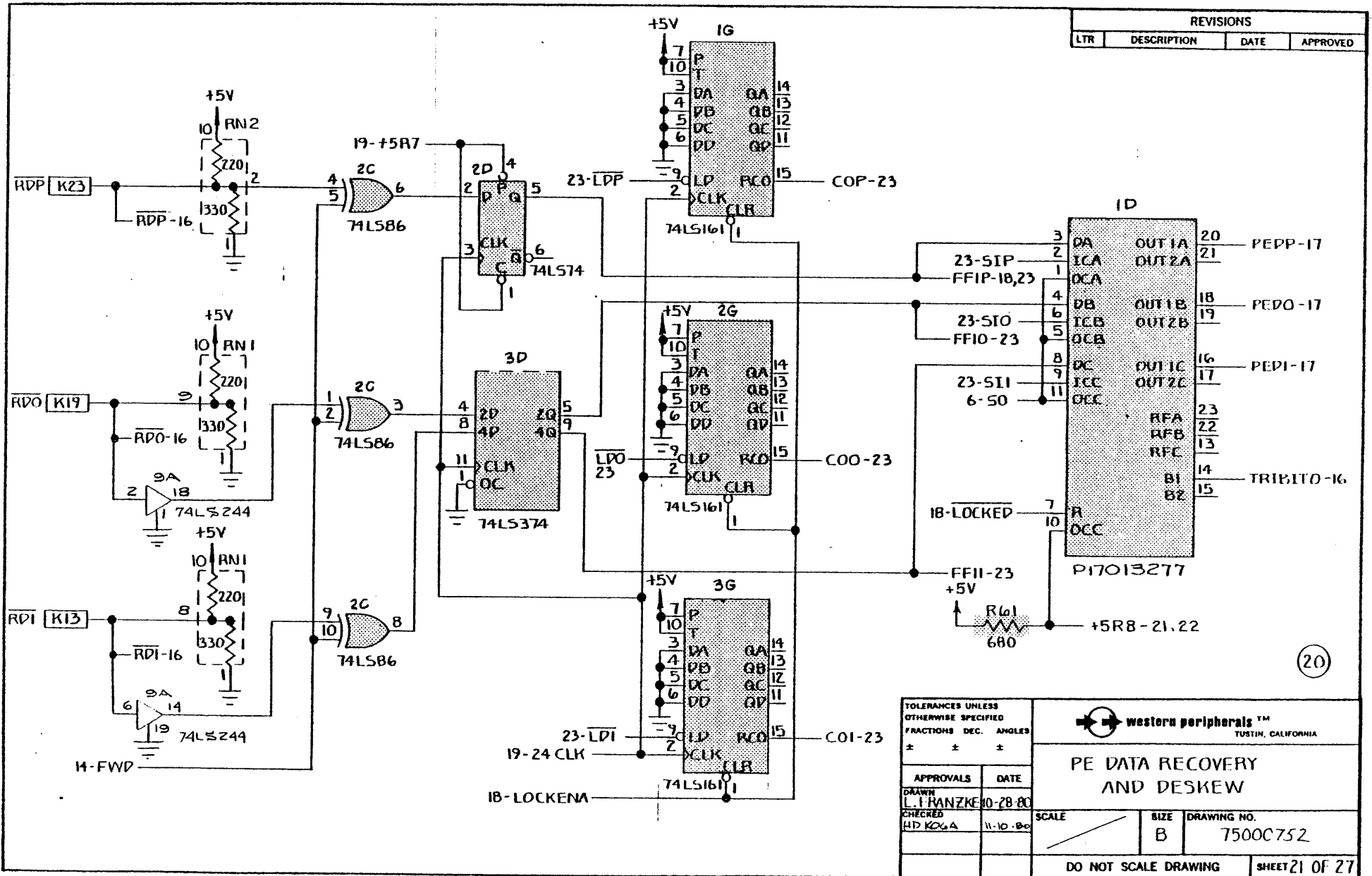

REVISIONS			
LTR	DESCRIPTION	DATE	APPROVED

(20)

TOLERANCES UNLESS OTHERWISE SPECIFIED  
FRACTIONS DEC. ANGLES  
\* \* \*

APPROVALS	DATE
DRAWN L. I. PANZKE	10-28-80
CHECKED HD KOGA	11-10-80

**western peripherals™**  
 TUSTIN, CALIFORNIA

PE DATA RECOVERY  
AND DESKEW

SCALE	SIZE B	DRAWING NO. 7500C752
DO NOT SCALE DRAWING		SHEET 21 OF 27



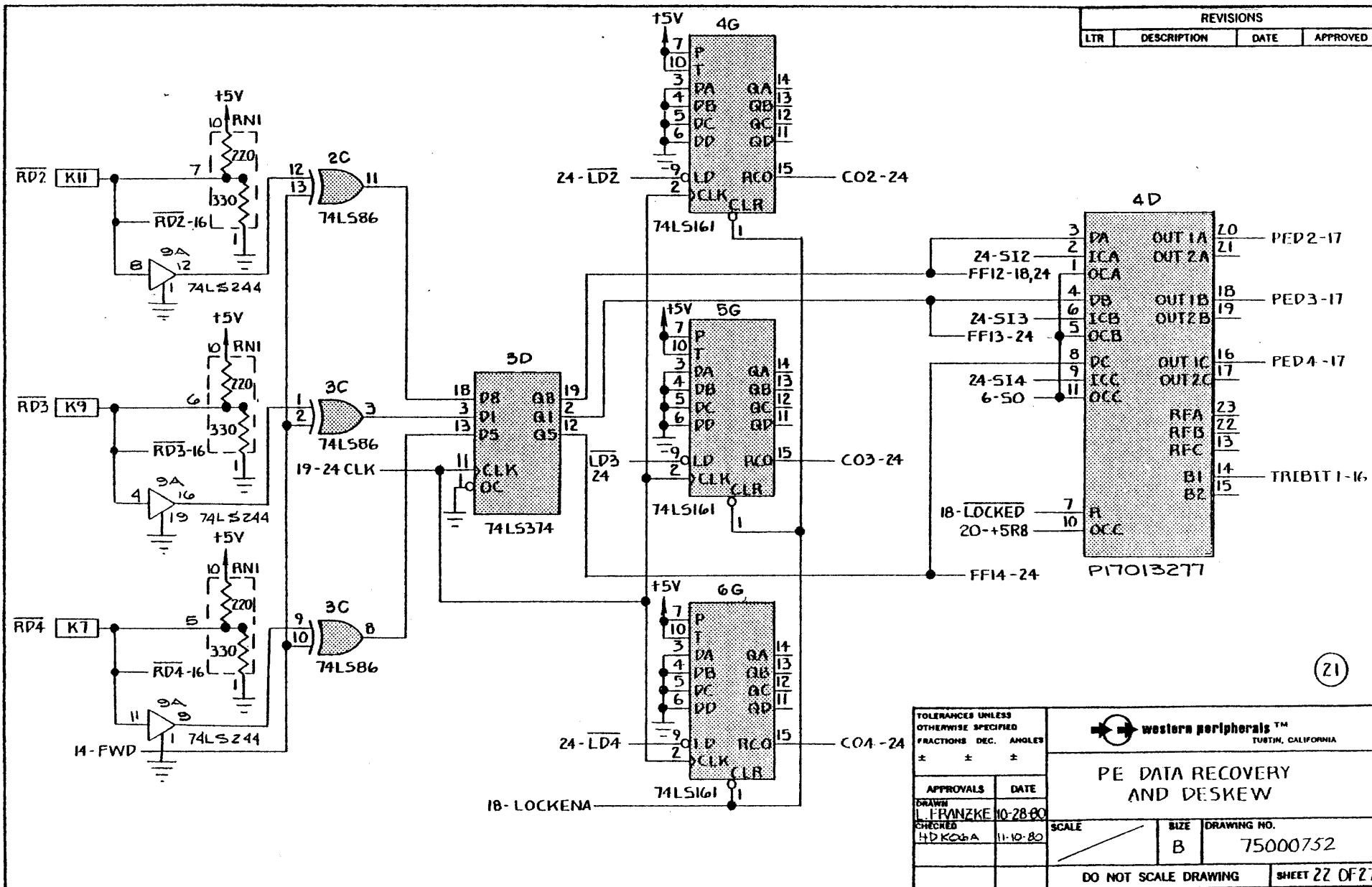

REVISIONS			
LTR	DESCRIPTION	DATE	APPROVED

(21)

TOLERANCES UNLESS OTHERWISE SPECIFIED		 western peripherals™ TUSTIN, CALIFORNIA	
FRACTIONS	DEC.		
±	±	±	<b>PE DATA RECOVERY AND DESKEW</b>
APPROVALS	DATE	SCALE	
DRAWN L. FRANZKE CHECKED H. P. KOEBA	10-28-80	1:10-80	
SIZE		DRAWING NO.	SHEET 22 OF 27
B		75000752	
DO NOT SCALE DRAWING			

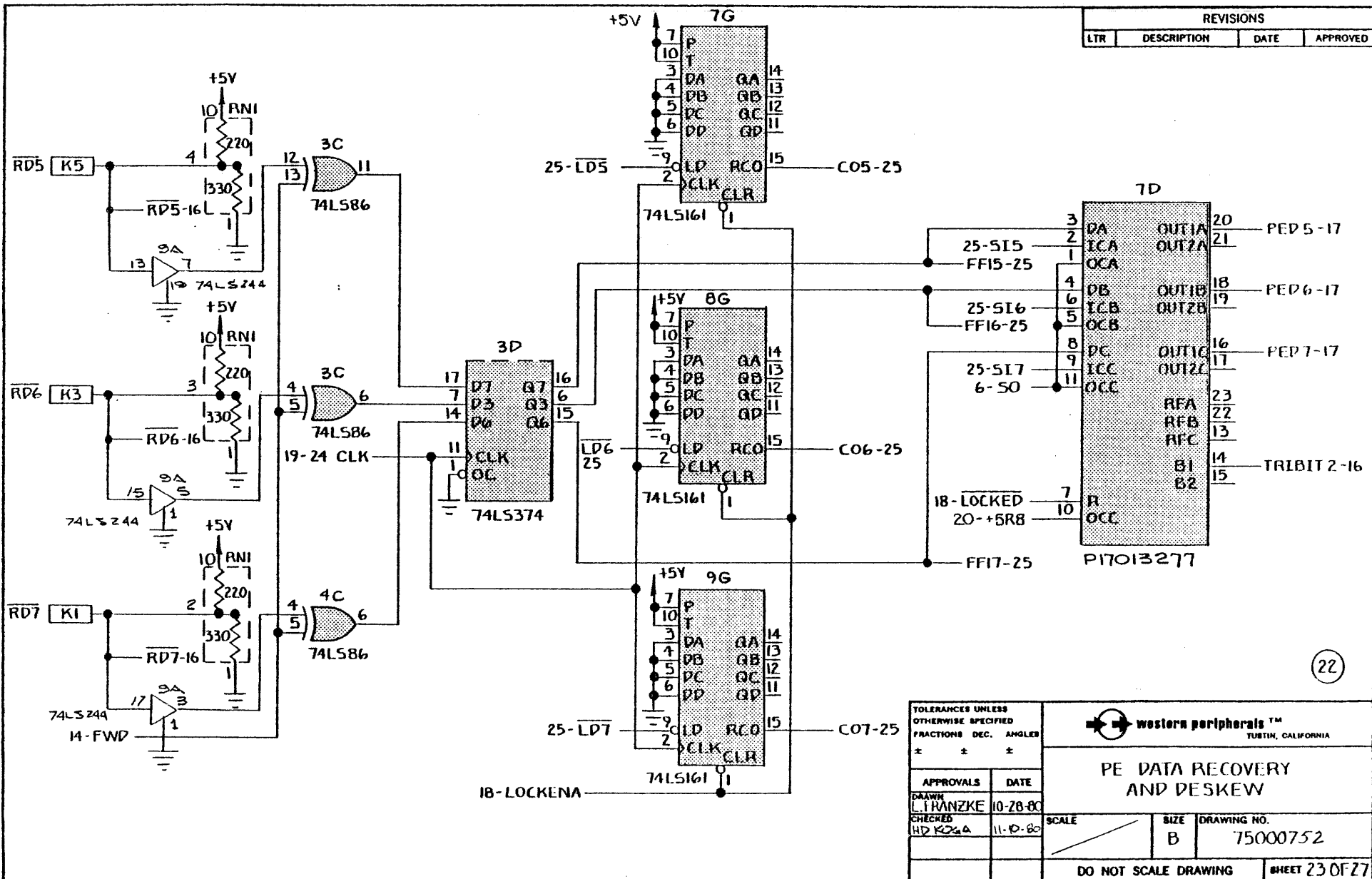

REVISIONS			
LTR	DESCRIPTION	DATE	APPROVED

22

TOLERANCES UNLESS OTHERWISE SPECIFIED FRACTIONS DEC. ANGLES		 <b>western peripherals™</b> TUSTIN, CALIFORNIA	
APPROVALS DRAWN L. FRANZKE CHECKED HD K26A		PE DATA RECOVERY AND DESKEW	
DATE 10-28-80 11-10-80		SCALE B	DRAWING NO. 75000752
DO NOT SCALE DRAWING			SHEET 23 OF 27

REVISIONS			
LTR	DESCRIPTION	DATE	APPROVED

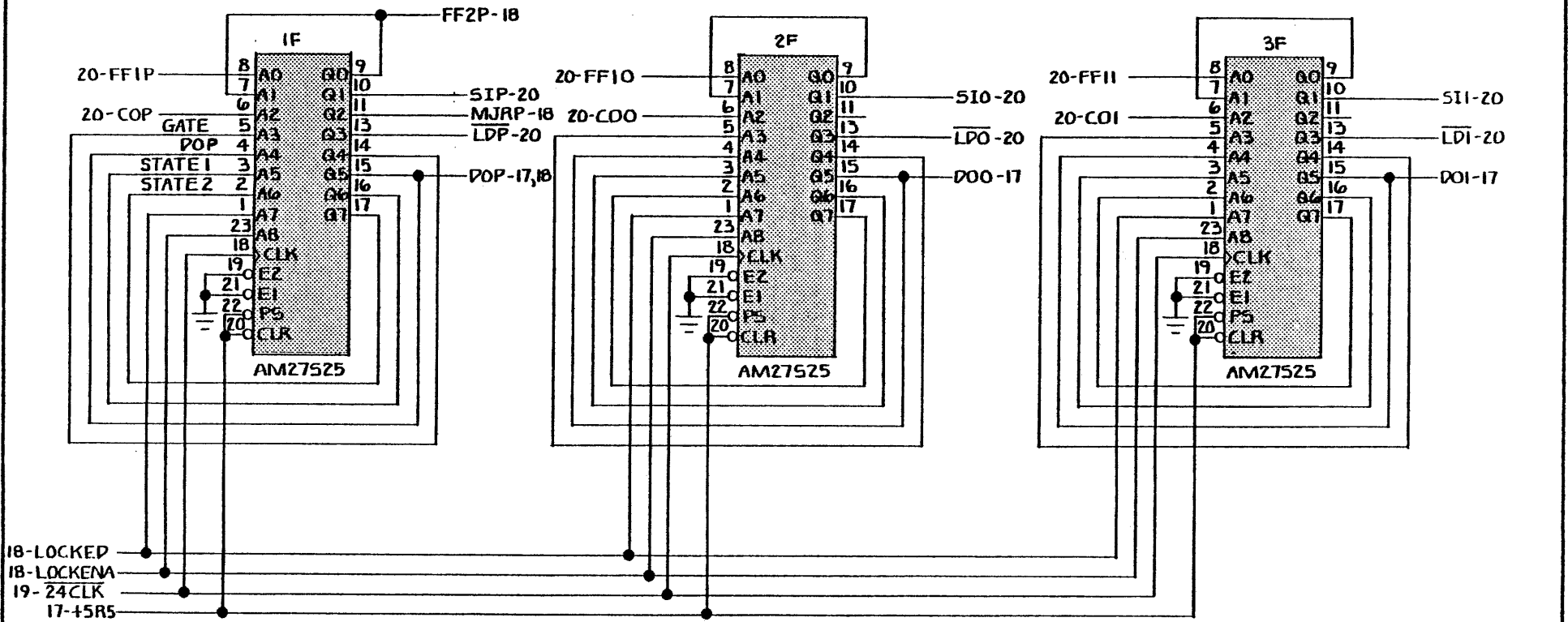

23

TOLERANCES UNLESS OTHERWISE SPECIFIED FRACTIONS DEC. ANGLES		 <b>western peripherals™</b> TUSTIN, CALIFORNIA		
±	±			<b>PE CHNL SEQ CTRL</b>
APPROVALS	DATE	SCALE	SIZE	
DRAWN L. FRANZKE	10-28-80		B	75000752
CHECKED HD KOGA	11-10-80			
DO NOT SCALE DRAWING				SHEET 24 OF 27

REVISIONS			
LTR	DESCRIPTION	DATE	APPROVED

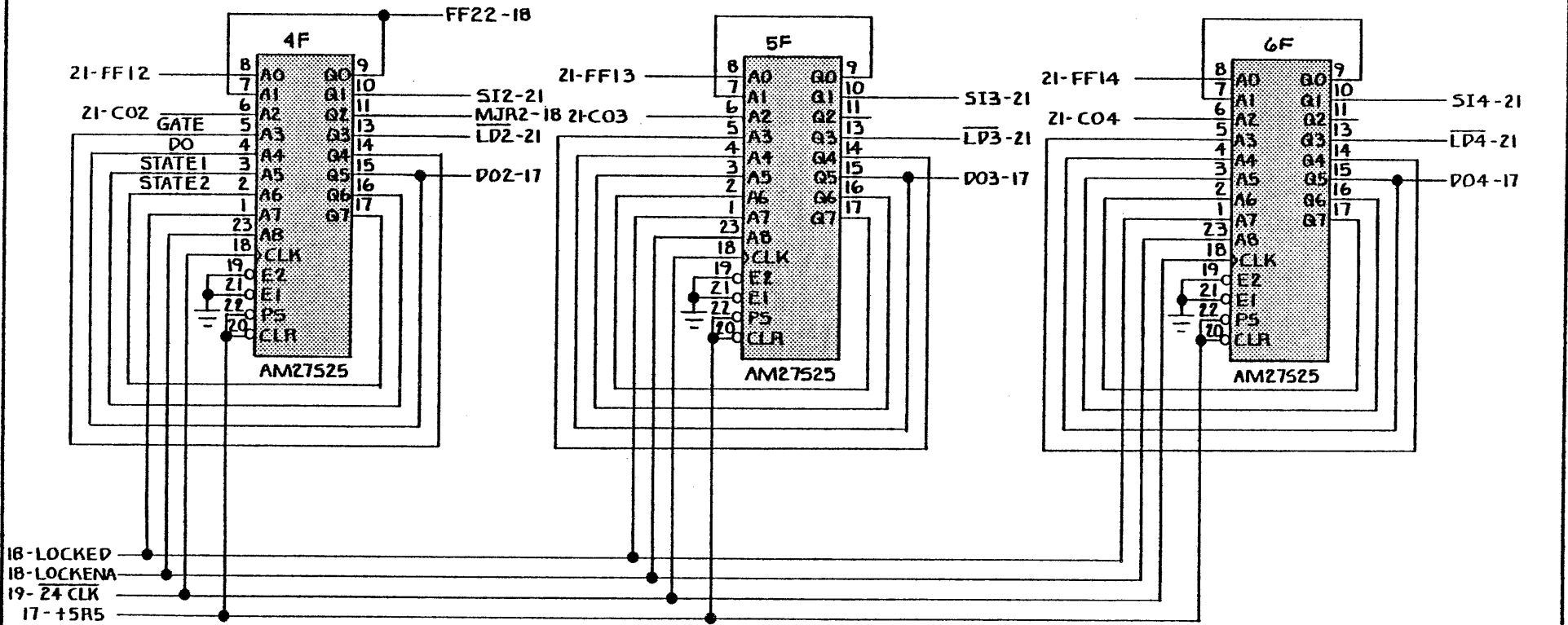

(24)

TOLERANCES UNLESS OTHERWISE SPECIFIED		<b>western peripherals™</b> TUSTIN, CALIFORNIA	
FRACTIONS DEC. ANGLES		<b>PE CHNL SEQ CTRL</b>	
±	±	±	±
APPROVALS	DATE	SCALE	SIZE
DRAWN L. FRANZKE	10-28-80		B
CHECKED HDICGA	11-10-80		DRAWING NO. 75000752
DO NOT SCALE DRAWING			SHEET 25 OF 27

REVISIONS			
LTR	DESCRIPTION	DATE	APPROVED

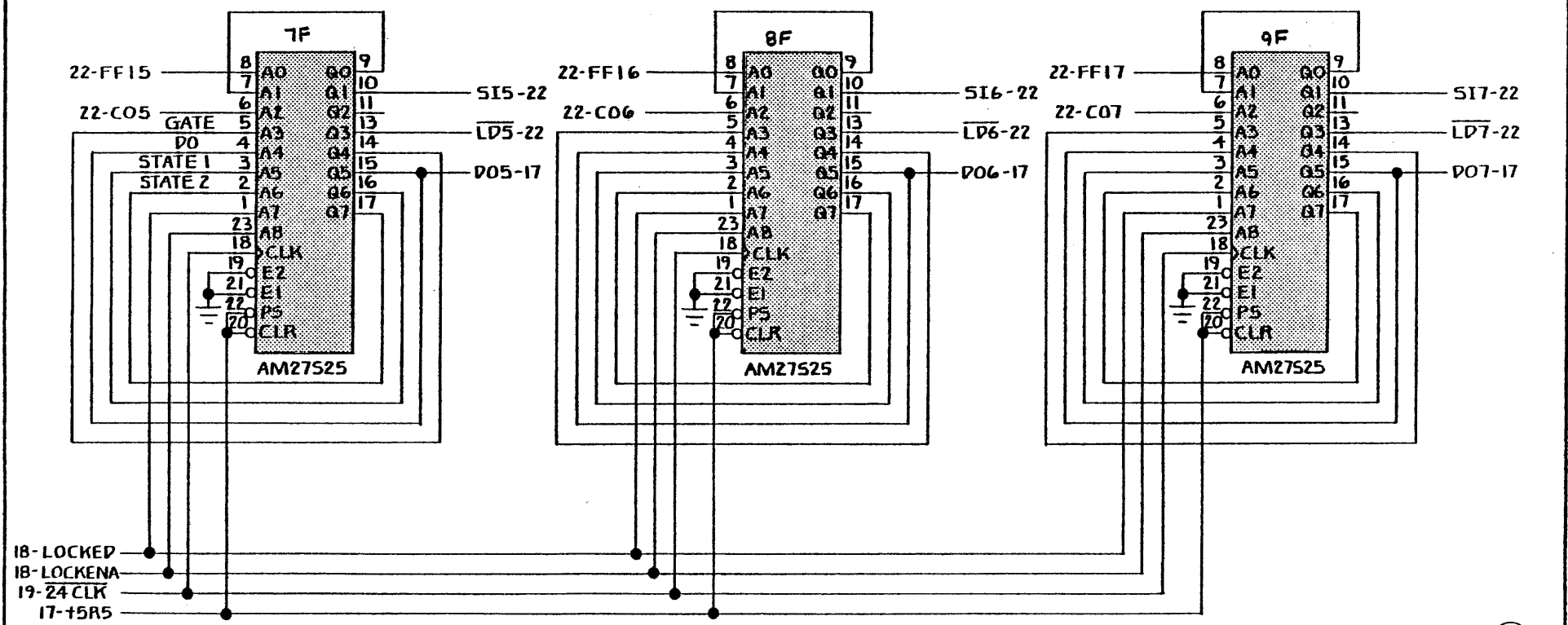

(25)

TOLERANCES UNLESS OTHERWISE SPECIFIED FRACTIONS DEC. ANGLES * * *		 western peripherals™ TUSTIN, CALIFORNIA	
APPROVALS      DATE L. FRANZKE 10-28-80 CHECKED      HDKOGA 11-10-80			
SCALE	SIZE	DRAWING NO.	
	B	75000752	
DO NOT SCALE DRAWING			SHEET 26 OF 27

REVISIONS			
LTR	DESCRIPTION	DATE	APPROVED

④ DEVICE ADDRESS  
STD ADDR 772520<sub>8</sub>

ADDR BIT	ADDR RANGE	E JUMPERS	STD ADDR	INSTALLED JUMPERS
17				
16				
15				
14				
13				
12				
11	0/1	28-20	0	X
10	0/1	27-19	1	
9	0/1	26-18	0	X
8	0/1	25-17	1	
7	0/1	24-16	0	X
6	0/1	23-15	1	
5	0/1	22-14	0	X
4	0/1	21-13	1	
3	X		X	
2	X		X	
1	X		X	
0	X		X	

INSTALL JUMPERS FOR "0's" IN DESIRED ADDR

⑪ OSCILLATOR JUMPERS

OPERATION	E JUMPERS
TEST FIXTURE	E73 → E75
NORMAL	E74 → E75

⑫ INTERRUPT PRIORITY LEVEL

BR4	BR5	BR6	BR7
E41 → E53	E43 → E55	E45 → E57	E47 → E59
E42 → E54	E44 → E56	E46 → E58	E48 → E60
E49 → E61	E50 → E62	E51 → E63	E52 → E64
E55 → E56	E53 → E54	E53 → E54	E53 → E54
E57 → E58	E57 → E58	E55 → E56	E55 → E56
E59 → E60	E59 → E60	E59 → E60	E57 → E58

⑬ INTERRUPT VECTOR  
STD VECTOR 224<sub>8</sub>

VCTR BIT	E JUMPERS	STD VCTR	INSTALLED JUMPERS
7	40-34	1	
6	39-33	0	X
5	38-32	0	X
4	37-31	1	
3	36-30	0	X
2	35-29	1	
1		0	
0		0	

INSTALL JUMPERS FOR "0's" IN DESIRED VECTOR

TOLERANCES UNLESS OTHERWISE SPECIFIED FRACTIONS DEC. ANGLES * ± ±		 <b>western peripherals™</b> TUSTIN, CALIFORNIA	
APPROVALS			
DRAWN C. Spada		12-15-80	
CHECKED			
SCALE		SIZE	DRAWING NO.
		B	75000752
DO NOT SCALE DRAWING			SHEET 27 OF 27

REVISIONS			
LTR	DESCRIPTION	DATE	APPROVED
A	INITIAL RELEASE	3-24-81	<i>lsh</i>

PURPOSE

This modification provides capability to control 12.5 and 18.75 ips drives.

1. Rework TC131 Assy 60000601 as follows:
  - a. Replace PROM in Location 27G with PROM P17017492
  - b. Jumper 3B-1 to 3B-14
  - c. Add 100 pf capacitor in parallel to existing capacitor C18
  - d. Add 390 pf capacitor in parallel to existing capacitor C20
  - e. Identify the Assy by marking "CONF A" on it using contrasting ink
2. For 12.5 ips drives, switch 4 on the tape control adapter at the drive end of the control cable must be open. Close it for 18.75 ips drives.
3. Material required:
  - a. Prom P17017492
  - b. 100 pf capacitor (W.P. P/N P15000136 or equivalent)
  - c. 390 pf capacitor (W.P. P/N P15000243 or equivalent)
4. The resultant changes to the TC131 schematic Sht (19) are shown on Sht 2 of this drawing.

NOTE: FOR NRZ ONLY UNIT (TC131N), SEE MOD DWG 79000709

MAR 26 1981

TOLERANCES UNLESS OTHERWISE SPECIFIED		 <b>western peripherals</b> ™ TUSTIN, CALIFORNIA	
FRACTIONS	DEC.		
±	±	±	Modification Drawing - TC131 Configuration "A"
APPROVALS	DATE		
DRAWN <i>H. Dentish</i>	3-24-81		
CHECKED <i>lsh</i>	3-24-81		SCALE
			SIZE <b>A</b>
			DRAWING NO. 79000683
DO NOT SCALE DRAWING			SHEET 1 OF 2

REVISIONS			
LTR	DESCRIPTION	DATE	APPROVED

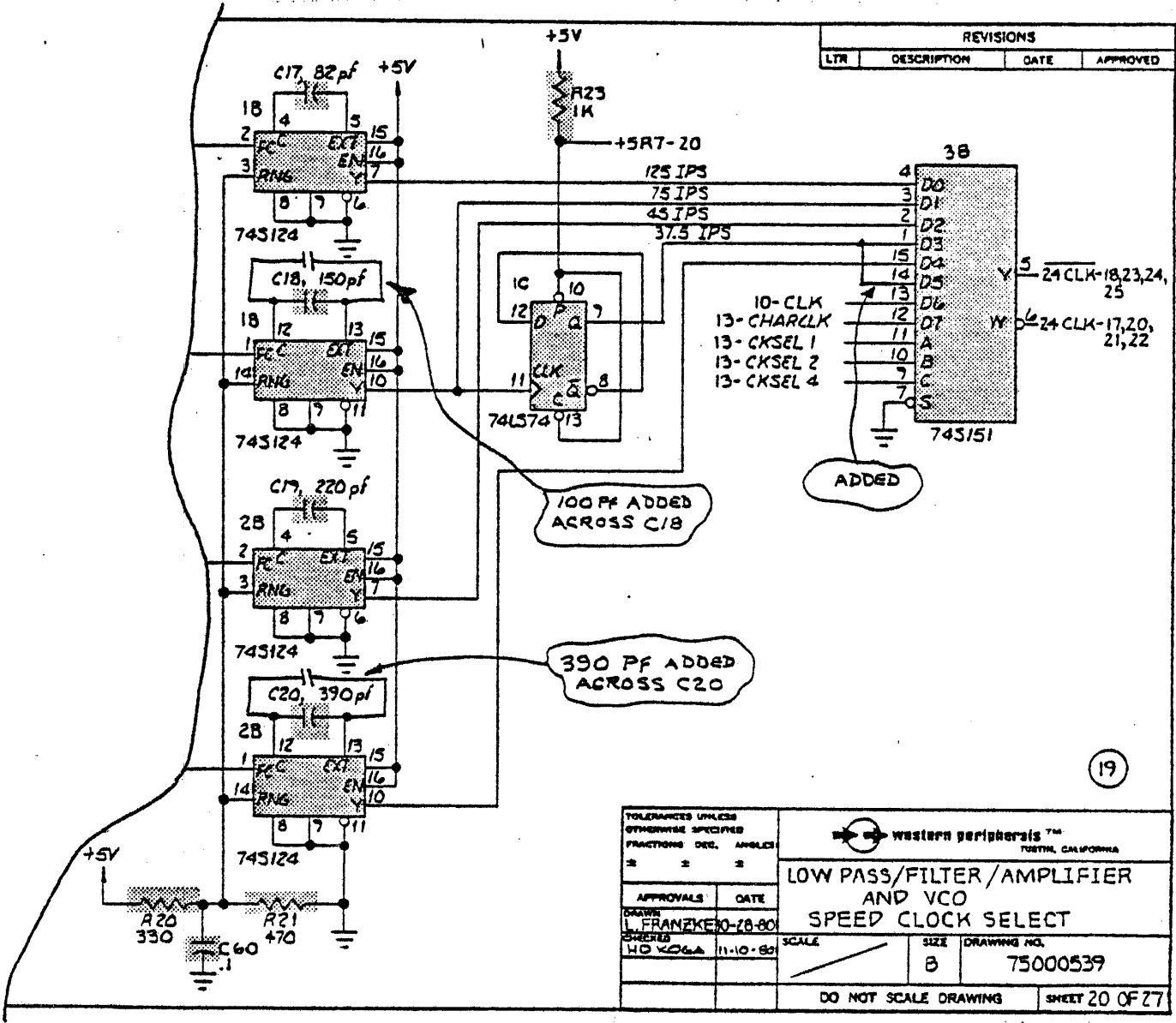

REVISIONS			
LTR	DESCRIPTION	DATE	APPROVED

19

TOLERANCES UNLESS OTHERWISE SPECIFIED		western peripherals™ TUSTIN, CALIFORNIA	
FRACTIONS DEC. ANGLES		LOW PASS/FILTER/AMPLIFIER AND VCO SPEED CLOCK SELECT	
APPROVALS	DATE	SCALE	SIZE DRAWING NO.
L. FRANKER	10-28-80		B 75000539
DESIGNED	HO VOGEL	11-10-80	
DO NOT SCALE DRAWING		SHEET 20 OF 27	

MAR 26 1981

SCALE	SIZE	DRAWING NO.
	<b>A</b>	79000683
DO NOT SCALE DRAWING		SHEET 2 OF 2



REVISIONS			
LTR	DESCRIPTION	DATE	APPROVED
A	INITIAL RELEASE	3-25-81	<i>dsz</i>

PURPOSE

This modification provides capability to control 12.5 and 18.75 ips drives.

1. Rework TC131N Assy 60000622 as follows:
  - a. Replace PROM in location 27G with PROM P17017492.
  - b. Identify the Assy by marking "CONF A" on it using contrasting ink.
2. For 12.5 ips drives, switch 4 on the tape control adapter at the drive end of the control cable must be open. Close it for 18.75 ips drives.
3. Material required:
  - a. PROM P17017492

NOTE: FOR PHASE ENCODED UNIT, SEE MOD DWG. 79000683

MAR 26 1981

TOLERANCES UNLESS OTHERWISE SPECIFIED FRACTIONS DEC. ANGLES $\pm$ $\pm$ $\pm$		 <b>western peripherals™</b> TUSTIN, CALIFORNIA	
APPROVALS      DATE DRAWN L. CRAWFORD      3-25-81		Modification Drawing - TC131N Configuration "A"	
CHECKED <i>H. Reutch</i> 3-25-81			
		SCALE	SIZE      DRAWING NO. <b>A</b> 79000709
DO NOT SCALE DRAWING			SHEET 1 OF 1





SEQ	PART NUMBER	DESCRIPTION	CON	QTY	URS	SUB	EXT	L	LOCATION	EFF DATE
000	LSC	NO INVENTORY ITEM		117	0					03/05/81
001	P17000027	IC 74LS00 QUAD 2 INP NAND		2	0				17B, 26E	01/05/81
002	P17000157	IC 74LS04 HEX INVERTER		1	0				5E	01/05/81
003	P17000159	IC 74S04 HEX INVERTER		1	0				25F	01/05/81
004	P17000233	IC 74LS08 QUAD 2 INP AND		3	0				10A, 5D, 27C	01/05/81
005	P17000290	IC 74S10 TRIPLE 3 INP NAND		2	0				25B, 25E	01/05/81
006	P17000308	IC 74LS10 TRIPLE 3 INP NAND		1	0				9E	01/05/81
007	P17000357	IC 74LS11 TRIPLE 3 INP AND		1	0				11F	01/05/81
008	P17000498	IC 74LS14 HEX INVERTER ST		2	0				18B, 26B	01/05/81
009	P17000852	IC 74LS30 8 INP NAND		1	0				14F	01/05/81
010	P17000910	IC 74LS32 QUAD 2 INP OR		3	0				11D, 5C, 27E	01/05/81
011	P17001041	IC 7438 QUAD 2 INP NAND DC BUF		2	0				15F, 17F	01/05/81
012	P17001561	IC 74S74 FLIP/FLOP DUAL D		1	0				23E	01/05/81
013	P17001579	IC 74LS74 FLIP/FLOP DUAL D		7	0				5A, 8A, 1C, 2D	01/05/81
013	P17001579	IC 74LS74 FLIP/FLOP DUAL D	1	CON	0				28D, 28E, 15F	01/05/81
014	P17001751	IC 74S86 QUAD 2 INP XOR		1	0				19A	01/05/81
015	P17001769	IC 74LS86 QUAD 2 INP XOR		3	0				2C, 3C, 4C	01/05/81
016	P17002155	IC 74LS123 ONE SHOT DUAL		2	0				11A, 9E	01/05/81
017	P17002171	IC 74S124 DUAL VOLT-COMT OSC		2	0				1B, 2E	01/05/81
018	P17002403	IC 74S138 DCDR/MUX 3-8 LINE		4	0				24A, 25C, 20F	01/05/81
018	P17002403	IC 74S138 DCDR/MUX 3-8 LINE	1	CON	0				24F	01/05/81
019	P17002911	IC 74LS138 DCDR/MUX 3-8 LINE		1	0				25D	01/05/81
020	P17002951	IC 74148 8-3 LINE ENCODER		1	0				25D	01/05/81
021	P17002977	IC 74S151 SEL/MUX 1 OF 8 LN		1	0				3B	01/05/81
022	P17002627	IC 74LS153 SEL/MUX DUAL 4-1		3	0				6A, 10F, 27F	01/05/81
023	P17002767	IC 74LS157 SEL/MUX QUAD 2-1		1	0				24B	01/05/81
024	P17002825	IC 74S158 SEL/MUX QUAD 2-1		1	0				26C	01/05/81
025	P17002890	IC 74LS161 CNTR 4 BIT BINARY		13	0				7A, 28F, 1E-9E	01/05/81
025	P17002890	IC 74LS161 CNTR 4 BIT BINARY	1	CON	0				25E, 26E	01/05/81
026	P17003229	IC 74LS174 FLIP/FLOP HEX TYP D		1	0				10E	01/05/81
027	P17003641	IC 74S240 DRVR/RCVR OCTAL BFR		3	0				14A, 12D, 14D	01/05/81
028	P17003690	IC 74LS244 DRVR/RCVR OCTAL BFR		8	0				25A, 2E, 7C, 8C	01/05/81
028	P17003690	IC 74LS244 DRVR/RCVR OCTAL BFR	1	CON	0				24C, 18F, 20F	01/05/81
028	P17003690	IC 74LS244 DRVR/RCVR OCTAL BFR	2	CON	0				29E	01/05/81
029	P17003757	IC 74S251 DATA SEL/MUX		3	0				17A, 15B, 16B	01/05/81
030	P17003898	IC 74LS259 8 BIT ADDRESSABLE LCH		2	0				25A, 22F	01/05/81
031	P17003963	IC 74265 QUAD COMP-OUTPUT GATE		1	0				22E	01/05/81
032	P17004003	IC 74276 QUAD J-K FLIP/FLOP		2	0				12A-6C	01/05/81
033	P17004110	IC 74LS280 9BIT PRY GEN/CHECK		1	0				11C	01/05/81
034	P17005141	IC 74LS373 OCTAL D TYPE LATCH		2	0				10B, 10C	01/05/81
035	P17005133	IC 74LS374 OCTAL TYPE D F/F		7	0				13A, 15A, 15A	01/05/81
035	P17005133	IC 74LS374 OCTAL TYPE D F/F	1	CON	0				13B, 9C, 9D	01/05/81
035	P17005133	IC 74LS374 OCTAL TYPE D F/F	2	CON	0				27D	01/05/81
036	P17003372	IC 74LS273 DUAL 4 BIT BIN CNTR		1	0				7E	01/05/81
037	P17006214	IC 74LS670 4 X 4 RFG FILES		2	0				24D, 24E	01/05/81
038	P17009853	IC 2901R 4 BIT SLICE		4	0				13E, 15E, 16E	01/05/81
038	P17009853	IC 2901R 4 BIT SLICE	1	CON	0				19E	01/05/81
039	P17009887	IC 2708 QUAD BUS TRANSMITTER		5	0				11E, 11E, 12E	01/05/81
040	P17009903	IC 2710 MICROPROCESSOR CNTR		1	0				12A	01/05/81
041	P17010093	IC HC 3901P QUAD OR AND		1	0				12E	01/05/81
042	P17008244	IC 8640 QUAD LINE DRVR		1	0				7E	01/05/81
043	P17008251	IC 8641 QUAD LINE XOR/INVT		1	0				18E	01/05/81

OUTSTANDING  
CHANGE ORDERS

904A 930  
915A 938  
 921B 947  
 924

JUL 16 1981

SEQ	PART NUMBER	DESCRIPTION	CON	QTY	HRS	SUB	EXC	L	LOCATION	REF DATE
044	P17008889	IC 9423 64 X 4 FIFO		2	.0				21F, 21G	01/05/81
045	P17015009	IC NE555 TIMER		1	.0				12E	01/05/81
046	P17009085	IC 25LS2521 8 BIT COMPARATOR		1	.0				12F	01/05/81
047	P17009705	IC 27S17 256 BIT PROM		1	.0				RAW PROM	03/05/81
048	P17009754	IC 27S25 512 X 8 REG PROM		22	.0				RAW PROMS	03/05/81
049	P17015280	IC 82S100 BIPOLAR FPLA 16X48X8		1	.0				RAW PROM	03/05/81
050		NO INVENTORY ITEM			.0					03/05/81
051		NO INVENTORY ITEM			.0					03/05/81
052		NO INVENTORY ITEM			.0					03/05/81
053		NO INVENTORY ITEM			.0					03/05/81
054		NO INVENTORY ITEM			.0					03/05/81
055		NO INVENTORY ITEM			.0					03/05/81
056		NO INVENTORY ITEM			.0					03/05/81
057		NO INVENTORY ITEM			.0					03/05/81
058		NO INVENTORY ITEM			.0					03/05/81
059		NO INVENTORY ITEM			.0					03/05/81
060		NO INVENTORY ITEM			.0					03/05/81
061		NO INVENTORY ITEM			.0					03/05/81
062		NO INVENTORY ITEM			.0					01/28/81
063		NO INVENTORY ITEM			.0					01/28/81
064		NO INVENTORY ITEM			.0					01/28/81
065		NO INVENTORY ITEM			.0					01/28/81
066		NO INVENTORY ITEM			.0					01/28/81
067		NO INVENTORY ITEM			.0					01/28/81
068		NO INVENTORY ITEM			.0					01/28/81
069		NO INVENTORY ITEM			.0					01/28/81
070		NO INVENTORY ITEM			.0					03/05/81
071	P17013269	IC SSI DESKEW/QUEUE REGISTER		3	.0				1D, 4D, 7D	01/05/81
072	P22000103	OSC K1114A 7.2 MHZ		1	.0				Y1	01/05/81
073	P22000186	OSC K1114A 10MHZ		1	.0				Y2	01/05/81
074	P14000251	RES 100 OHM 1/4W 5% RC070F101J		2	.0				R18, R37	01/05/81
075	P14000293	RES 180 OHM 1/4W 5% RC070F181J		7	.0				R26, R34, R36,	01/05/81
075	P14000293	RES 180 OHM 1/4W 5% RC070F181J	1	CON	.0				R49, R59, R60,	01/05/81
075	P14000293	RES 180 OHM 1/4W 5% RC070F181J	2	CON	.0				R42	01/05/81
076	P14000350	RES 330 OHM 1/4W 5% RC070F331J		3	.0				R14, R15, R20	01/05/81
077	P14000376	RES 390 OHM 1/4W 5% RC070F391J		2	.0				R35, R37	01/05/81
078	P14000392	RES 470 OHM 1/4W 5% RC070F471J		1	.0				R21	01/05/81
079	P14000426	RES 680 OHM 1/4 W RC070F681J		20	.0				R9, R12, R13,	01/05/81
079	P14000426	RES 680 OHM 1/4 W RC070F681J	1	CON	.0				R16, R17, R19,	01/05/81
079	P14000426	RES 680 OHM 1/4 W RC070F681J	2	CON	.0				R22, R24, R25,	01/05/81
079	P14000426	RES 680 OHM 1/4 W RC070F681J	3	CON	.0				R27, R28, R31,	01/05/81
079	P14000426	RES 680 OHM 1/4 W RC070F681J	4	CON	.0				R32, R33, R38,	01/05/81
079	P14000426	RES 680 OHM 1/4 W RC070F681J	5	CON	.0				R40, R41, R42,	01/05/81
079	P14000426	RES 680 OHM 1/4 W RC070F681J	6	CON	.0				R43, R44	01/05/81
080	P14000467	RES 1K OHM 1/4W 5% RC070F102J		9	.0				R5, R7, R8, R23	01/05/81
080	P14000467	RES 1K OHM 1/4W 5% RC070F102J	1	CON	.0				R44, R45, R48	01/05/81
081	P14000509	RES 1.5K 1/4W 5% RC070F152J		3	.0				R1, R2, R4	01/05/81
082	P14000541	RES 2.2K 1/4W 5% RC070F222J		1	.0				R57	01/05/81
083	P14000553	RES 2.7K 1/4W 5% RC070F272J		2	.0				R54, R55	01/05/81
084	P14000603	RES 4.3K 1/4W 5% RC070F432J		1	.0				R52	01/05/81
085	P14000616	RES 4.7K 1/4W 5% RC070F472J		2	.0				R10, R13	01/05/81
086	P14000640	RES 6.8K 1/4W 5% RC070F682J		2	.0				R3, R4	01/05/81

JUL 16 1981

SEQ	PART NUMBER	DESCRIPTION	CON	QTY	HRS	SUB	EXC	L	LOCATION	EFF DATE
087	P14000755	RES. 150K 1/4 W RC070F154J		1	.0				R11	01/05/81
088	P14000806	RES. 470K 1/4 W RC070F474J		3	.0				R3, R6, R29	01/05/81
088	P14000806	RES. 470K 1/4 W RC070F474J	1	CON	.0				R30, R53, R56	01/05/81
087	P14000863	RES. 1 MEG 1/4 W RC070F105J		1	.0				R49	01/05/81
090	P14004311	RESP 10PIN 785-5-R220/330		3	.0				RN1, RN2, RN3	01/05/81
091	P14004485	RESP 10PIN 785-1-R1K		2	.0				RN4, RN5	01/05/81
092	P11000007	DIU IN914A SIGNAL HIGH SPEED		8	.0				CR1 THRU CR3	01/05/81
093	P15000128	CAP 82PF 500V CM05ED820J03		1	.0				C17	01/05/81
094	P15005127	CAP 150PF CM05ED151J03		1	.0				C18	01/05/81
095	P15005184	CAP 220PF CM05ED221J03		4	.0				C12, C13, C12,	01/05/81
095	P15005184	CAP 220PF CM05ED221J03	1	CON	.0				C55	01/05/81
096	P15000250	CAP 390PF 500V CM05ED391J03		1	.0				C20	01/05/81
097	P15000631	CAP 4700PF 100V CK05BX472K		1	.0				C7	01/05/81
098	P15000672	CAP 5600PF 100V CK05BX562K		2	.0				C1, C6	01/05/81
099	P15000714	CAP 6800PF 50V CK05BX682K		1	.0				C4	01/05/81
100	P15000490	CAP .001MF 200V CK05BX102K		4	.0				C32, C44, C45,	01/05/81
100	P15000490	CAP .001MF 200V CK05BX102K	1	CON	.0				C48	01/05/81
101	P15000763	CAP .01MF 100V CK05BX103K		1	.0				C35	01/05/81
102	P15000805	CAP .056MF 50V CK05BX563K		1	.0				C2	01/05/81
103	P15000821	CAP .068MF 50V CK05BX683K		2	.0				C5, C8	01/05/81
104	P15000870	CAP .082MF 50V CK05BX823K		1	.0				C3	01/05/81
105	P15000904	CAP .1MF 50V CK05BX104K		6	.0				C36, C56 THRU	01/05/81
105	P15000904	CAP .1MF 50V CK05BX104K	1	CON	.0				C60	01/05/81
106	P15002348	CAP 4.7MF 10V 150D475X9010A2		34	.0				C9, C10, C11,	01/05/81
106	P15002348	CAP 4.7MF 10V 150D475X9010A2	1	CON	.0				C14, C15, C16,	01/05/81
106	P15002348	CAP 4.7MF 10V 150D475X9010A2	2	CON	.0				C21 THRU C31	01/05/81
106	P15002348	CAP 4.7MF 10V 150D475X9010A2	3	CON	.0				C33, C34, C37	01/05/81
106	P15002348	CAP 4.7MF 10V 150D475X9010A2	4	CON	.0				THRU C43, C45	01/05/81
106	P15002348	CAP 4.7MF 10V 150D475X9010A2	5	CON	.0				C47, C49 THRU	01/05/81
106	P15002348	CAP 4.7MF 10V 150D475X9010A2	6	CON	.0				C54	01/05/81
107	P20000147	SW 8 PIN DIP 206-4		1	.0				288	01/05/81
108	P21000062	LED 555-2003IDIALC03		5	.0				LED1-LED5	01/05/81
109	P23007180	CONN IC SKT 8P DILB-8-P-108		12	.0				19B, 21B,	01/28/81
109	P23007180	CONN IC SKT 8P DILB-8-P-108	1	CON	.0				19C-A, 19C-B,	01/28/81
109	P23007180	CONN IC SKT 8P DILB-8-P-108	2	CON	.0				21C-A, 21C-B,	01/28/81
109	P23007180	CONN IC SKT 8P DILB-8-P-108	3	CON	.0				19D-A, 19D-B,	01/28/81
109	P23007180	CONN IC SKT 8P DILB-8-P-108	4	CON	.0				21D-A, 21D-B,	02/03/81
109	P23007180	CONN IC SKT 8P DILB-8-P-108	5	CON	.0				19E, 21E	02/03/81
110	P23007198	CONN IC SKT 16P DILB-16-P-108		12	.0				19B, 21B,	01/28/81
110	P23007198	CONN IC SKT 16P DILB-16-P-108	1	CON	.0				19C-A, 19C-B,	01/28/81
110	P23007198	CONN IC SKT 16P DILB-16-P-108	2	CON	.0				21C-A, 21C-B,	01/28/81
110	P23007198	CONN IC SKT 16P DILB-16-P-108	3	CON	.0				19D-A, 19D-B,	01/28/81
110	P23007198	CONN IC SKT 16P DILB-16-P-108	4	CON	.0				21D-A, 21D-B,	02/03/81
110	P23007198	CONN IC SKT 16P DILB-16-P-108	5	CON	.0				19E, 21E	02/03/81
111	P23000383	CONN IC SKT 28P IEW3700-2800		1	.0				19C	01/05/81
112	P26002733	W/W POST STRIP, BERG 65500-104		20	.0				F1 THRU F75	01/05/81
113	P03300175-01	SPEC CARD PULL HOE WHI		3	.0					01/05/81
114	P42000133	EYELET, SE-47 BRASS		6	.0					01/05/81
115	P76000520-B	PWD IC131 TAPE CONTROLLER		1	.0					01/21/81
116	P75000539	SCH IC131 TAPE CONTROLLER		REF	.0					01/20/81
117	P170003666	IC 74LS240 OCTAL BUFFER 3 ST		1	.0				C97	01/05/81
118	P180001313	PRST PRDH SET IC131		REF	.0					01/05/81

JUL 16 1981

04/22/81 BILL OF MATERIAL TOP LEVEL ASSEMBLY LIST  
ASSEMBLY NO. P50000601

PAGE 4  
REVISION *MF* DESC: ASSY TC 131 TAPE CONTROLLER

SEQ	PART NUMBER	DESCRIPTION	CON QTY	HRS	SUB	EXC L	LOCATION	EFF DATE
119	P18001321	PRST, TC131/151, PE	REF		0			03/05/81

JUL 16 1981

APPROVAL	CHANGE CHAIRMAN	DATE	CHANGE TYPE	DISPOSITION	DRAWINGS AFFECTED	OLD REV	NEW REV	DATE INCORP
	PRODUCT ENG'R	4/28/81	<input type="checkbox"/> DESIGN IMPROVEMENT	<input type="checkbox"/> NO AFFECT	TC-131			
	MFG.	4/24/81	<input checked="" type="checkbox"/> IN-LINE	<input checked="" type="checkbox"/> USE AS IS	ASSY 60000601	G	H	
	Q.C.	4/28	<input type="checkbox"/> MANDATORY	<input type="checkbox"/> SCRAP	B/M 60000601	G	H	
	MKTG.	4/28	<input type="checkbox"/> RECORD ONLY	<input type="checkbox"/> REWORK	ASSY 60000692	F	G	
	TECH SUPPORT	4-28	<input type="checkbox"/>	<input checked="" type="checkbox"/> RETROFIT AS REQ'D	B/M 60000692	F	G	
			<input type="checkbox"/> NON-INTERCHANGEABLE		PWM (ARTWORK) 76000520	B	T&D	
			<input checked="" type="checkbox"/> 1-WAY INTERCHANGEABLE		PWB (FAB) 76000520	B	T&D	
			<input type="checkbox"/> 2-WAY INTERCHANGEABLE					
			<input type="checkbox"/> PROD. IMPROV. BULLETIN REQ'D					
			<input type="checkbox"/> MFG. WORK SHEET ON FILE					
ORIGINATOR R ANDERSON		MGR	EFFECTIVITY (DATE OR 1ST SERIAL NO.)					
DRAWN BY ROGER ANDERSON		4-23-81	SERIAL NO. 336					

REASON FOR CHANGE (USE ATTACHMENTS IF NECESSARY)  
SYMPTOM:

FIELD SELECTION JUMPERS-IN-ETCH ARE INACCESSABLE

PROBLEM: INDIVIDUAL WIRE-WRAP POSTS WERE REPLACED BY WIRE-WRAP POST STRIPS WHICH NOW COVER THE ETCH JUMPERS.

SOLUTION: RELOCATE THESE JUMPERS TO THE SOLDER SIDE OF THE BOARD

DETAILED DESCRIPTION OF CHANGE TO AFFECTED DOCUMENTS AND/OR PARTS (USE CONTINUATION SHTS, IF REQ'D, TO SHOW REWORK, SCHEMATIC CHANGES, ASSY CHANGES, B/M CHANGES, ETC.)

ON PWM, 76000520 - MOVE THE FOLLOWING ETCH JUMPERS FROM THE COMPONENT SIDE TO THE SOLDER SIDE OF THE BOARD:  
E 44 TO E 56, E 57 TO E 58

REV A CHANGES REV LTR OF DWGS  
CC 56-81 Q.C.  
ENG. MKTG.  
MFG. T.S.

ON PWB, 76000520 - CUT THE ETCH JUMPERS LISTED ABOVE BEFORE INSTALLING COMPONENTS. REPLACE WITH WIRE-WRAP JUMPERS.  
(REWORK UNTIL NEW BOARDS ARE AVAILABLE.)

JUL 16 1981

ON ASSY 60000601 & 60000692  
UPGRADE REV LTR TO REFLECT THE CHANGE ON THIS ECO  
COORDINATE WITH ECO 897





ENGINEERING CHANGE REQUEST/ORDER

SHEET 1 OF 1  
CANCELLED BY E.C.O. NO.

E.C.O. NO. 915

REV A

APPROVAL	CHANGE CHAIRMAN	DATE	CHANGE TYPE	DISPOSITION	DRAWINGS AFFECTED	OLD REV	NEW REV	DATE INCORP
	PRODUCT	5-5-81	<input type="checkbox"/> DESIGN IMPROVEMENT	<input type="checkbox"/> NO AFFECT	TC131/131N			
	ENG'R	5/5/81	<input checked="" type="checkbox"/> IN-LINE	<input checked="" type="checkbox"/> USE AS IS	Assy			
	MFG.	5-5-81	<input type="checkbox"/> MANDATORY	<input type="checkbox"/> SCRAP	60000601	F	G	
	Q.C.	5/5/81	<input type="checkbox"/> RECORD ONLY	<input type="checkbox"/> REWORK	B/M			
	MKTG.		<input type="checkbox"/> _____	<input checked="" type="checkbox"/> RETROFIT AS REQ'D	60000601	F	G	
TECH SUPPORT	5/5	<input type="checkbox"/> NON-INTERCHANGEABLE		Assy				
		<input checked="" type="checkbox"/> 1-WAY INTERCHANGEABLE		60000692	E	F		
		<input type="checkbox"/> 2-WAY INTERCHANGEABLE		B/M				
		<input type="checkbox"/> PROD. IMPROV. BULLETIN REQ'D		60000692	E	F		
		<input type="checkbox"/> MFG. WORK SHEET ON FILE						

ORIGINATOR: D. GLEEDVIG  
MGR: \_\_\_\_\_  
DRAWN BY: B. MIDDLETON  
DATE: 5-4-81

EFFECTIVITY (DATE OR 1ST SERIAL NO.)  
ALL UNITS NOT IN Finished Goods AS OF 5-6-81

REASON FOR CHANGE (USE ATTACHMENTS IF NECESSARY)  
SYMPTOM:  
THE BOARD IS NOT 100% COMPATABLE WITH OUR TESTER  
PROBLEM: TIMER FREQUENCY WILL NOT RUN AT THE CORRECT SPEED TO READ CERTAIN DEC DIAGNOSTICS.  
SOLUTION:  
REPLACE THE RESISTORS @ LOCATIONS R29 & R30 TO CORRECT SPEED

DETAILED DESCRIPTION OF CHANGE TO AFFECTED DOCUMENTS AND/OR PARTS (USE CONTINUATION SHTS, IF REQ'D, TO SHOW REWORK, SCHEMATIC CHANGES, ASSY CHANGES, B/M CHANGES, ETC.)

1) ON ASSY & B/M 60000601  
ITEM 88 - QTY 15 6 S/B 4 - DELETE LOCATIONS R29 & R30  
ITEM 78 - QTY 15 1 S/B 3 - ADD LOCATIONS R29 & R30

2) ON ASSY & B/M 60000692  
ITEM 69 - P/N 15 P14000806 S/B P14000392

JUL 16 1981

REVA CHANGES DWG-NO  
REV LTRS.  
CC. 8/2 5-6-81  
ENG. \_\_\_\_\_  
MFG. \_\_\_\_\_  
Q.C. \_\_\_\_\_  
MKTG. \_\_\_\_\_  
T.S. \_\_\_\_\_

APPROVAL	CHANGE CHAIRMAN	DATE	CHANGE TYPE	DISPOSITION	DRAWINGS AFFECTED	OLD REV	NEW REV	DATE INCORP
	PRODUCT ENG'R	5/12/81	<input type="checkbox"/> DESIGN IMPROVEMENT <input checked="" type="checkbox"/> IN-LINE <input type="checkbox"/> MANDATORY <input type="checkbox"/> RECORD ONLY	<input type="checkbox"/> NO AFFECT <input type="checkbox"/> USE AS IS <input type="checkbox"/> SCRAP <input type="checkbox"/> REWORK <input checked="" type="checkbox"/> RETROFIT AS REQ'D	TC131 ASEY 60000601	H	J	
	MFG.	5/12/81	<input type="checkbox"/>		B/M 60000601	H	J	
	Q.C.	5/12/81	<input type="checkbox"/>					
	MKTG.	5-13-81	<input type="checkbox"/> NON-INTERCHANGEABLE <input checked="" type="checkbox"/> 1-WAY INTERCHANGEABLE <input type="checkbox"/> 2-WAY INTERCHANGEABLE <input type="checkbox"/> PROD. IMPROV. BULLETIN REQ'D <input type="checkbox"/> MFG. WORK SHEET ON FILE					
	TECH SUPPORT	5/12						
ORIGINATOR	MGR		EFFECTIVITY (DATE OR 1ST SERIAL NO.) ALL UNITS IN HOUSE/ RETROFIT AS REQ'D (FIELD RTNS)					
DRAWN BY		5-11-81						

REASON FOR CHANGE (USE ATTACHMENTS IF NECESSARY)  
 SYMPTOM:  
 EXCESSIVE P.E. READ PARITY ERRORS WITH CERTAIN DRIVES - I.E. CIPHER

PROBLEM:  
 HIGH NOISE LEVELS ON THE READ SIGNALS TO THE 74LS86 I.C.'S AT 2C, 3C, 4C

SOLUTION:  
 SELECT 74LS86 I.C.'S WITH THRESHOLD LEVELS ON THE HIGH END OF MFGR'S SPEC.

DETAILED DESCRIPTION OF CHANGE TO AFFECTED DOCUMENTS AND/OR PARTS (USE CONTINUATION SHTS, IF REQ'D, TO SHOW REWORK, SCHEMATIC CHANGES, ASSY CHANGES, B/H CHANGES, ETC.)

1.) PRE-TEST 74LS86 I.C.'S TO THE HIGH THRESHOLD (1.2 VOLTS)  
 THOSE PARTS THAT PASS MUST BE IDENTIFIED WITH A NEW P/N - P17001777

2.) ON ASSY & B/M -  
 ITEM 15 IS P17001769  
 SIB P17001777

REV B CHANGES EFFECTIVITY TO ALL UNITS

CC. [Signature]  
 MFG. [Signature]  
 Q.C. [Signature]  
 MFG. D. Smith  
 T.S. [Signature] 5/31

REV A CORRECTS DWGS. AFFECTED BY ELIMINATING 6000692 131 N

CC. [Signature]  
 MFG. [Signature]  
 Q.C. [Signature]  
 MFG. [Signature]  
 T.S. [Signature]

JUL 16 1981

ENGINEERING CHANGE REQUEST/ORDER

SHEET 1 OF 1  
CANCELLED BY E.C.O. NO.

E.C.O. NO. 924

REV

APPROVAL	CHANGE CHAIRMAN	DATE	<b>CHANGE TYPE</b> <input type="checkbox"/> DESIGN IMPROVEMENT <input type="checkbox"/> IN-LINE <input type="checkbox"/> MANDATORY <input checked="" type="checkbox"/> RECORD ONLY  <input type="checkbox"/> NON-INTERCHANGEABLE <input checked="" type="checkbox"/> 1-WAY INTERCHANGEABLE <input type="checkbox"/> 2-WAY INTERCHANGEABLE <input type="checkbox"/> PROD. IMPROV. BULLETIN REQ'D <input type="checkbox"/> MFG. WORK SHEET ON FILE	<b>DISPOSITION</b> <input type="checkbox"/> NO AFFECT <input checked="" type="checkbox"/> USE AS IS <input type="checkbox"/> SCRAP <input type="checkbox"/> REWORK <input type="checkbox"/> RETROFIT AS REQ'D	<b>DRAWINGS AFFECTED</b> TC 131 ASSY 60000601 B/M 60000601	<table border="1"> <tr> <th>OLD REV</th> <th>NEW REV</th> <th>DATE INCORP</th> </tr> <tr> <td>J</td> <td>J1</td> <td></td> </tr> <tr> <td>J</td> <td>J1</td> <td></td> </tr> </table>	OLD REV	NEW REV	DATE INCORP	J	J1		J	J1	
	OLD REV	NEW REV					DATE INCORP								
	J	J1													
	J	J1													
	PRODUCT ENG'R														
	MFG.	5/12/81													
Q.C.	5/12/81														
MKTG.	5-12-81														
TECH SUPPORT	5-12														
ORIGINATOR	MGR	EFFECTIVITY (DATE OR 1ST SERIAL NO.)	NO EFFECT (R/C ONLY)												
R. SHEFFER															
DRAWN BY															
GARY WOOD	5-8-81														

REASON FOR CHANGE (USE ATTACHMENTS IF NECESSARY)  
 SYMPTOM:  
 PULLING INCORRECT FOR KITS.

PROBLEM:  
 B/M CALLS OUT RAW PROMS ON PROM WHICH ARE STOCKED AS BLOWN PROMS.

SOLUTION:  
 CORRECT B/M TO SHOW P/N OF BLOWN PROMS.

DETAILED DESCRIPTION OF CHANGE TO AFFECTED DOCUMENTS AND/OR PARTS (USE CONTINUATION SHEETS, IF REQ'D, TO SHOW REWORK, SCHEMATIC CHANGES, ASSY CHANGES, B/M CHANGES, ETC.)

PG00000601

1.) ITEM 48:	$\frac{15}{22}$	$\frac{5/B}{13}$	QTY.	QTY.
--------------	-----------------	------------------	------	------

2.) ADD ITEM 50:	QTY.	PART NO.	LOCATION
	9	P17019837	1F-9F

JUL 16 1981

ENGINEERING CHANGE REQUEST/ORDER

SHEET OF 1  
 CANCELLED BY E.C.O. NO.

E.C.O. NO. 930

REV

APPROVAL	CHANGE CHAIRMAN	DATE	CHANGE TYPE	DISPOSITION	DRAWINGS AFFECTED	OLD REV	NEW REV	DATE INCORP
	ENG'R	5-15-81	<input checked="" type="checkbox"/> IN-LINE	<input type="checkbox"/> NO AFFECT	TC131			
	MFG	5-15-81	<input type="checkbox"/> MANDATORY	<input type="checkbox"/> USE AS IS	ASSY 60000601	J1	K	
	Q.C.	5/15/81	<input type="checkbox"/> RECORD ONLY	<input type="checkbox"/> SCRAP	B/M 60000601	J1	K	
	HKTG.		<input type="checkbox"/> NON-INTERCHANGEABLE	<input checked="" type="checkbox"/> RETROFIT AS REQ'D				
	TECH SUPPORT	5-15	<input checked="" type="checkbox"/> 1-WAY INTERCHANGEABLE	<input type="checkbox"/> 2-WAY INTERCHANGEABLE				
			<input type="checkbox"/> PROD. IMPROV. BULLETIN REQ'D					
			<input type="checkbox"/> MFG. WORK SHEET ON FILE					
ORIGINATOR		MGR	EFFECTIVITY (DATE OR 1ST SERIAL NO.)					
D. GREDVIG			S/N 0336					
DRAWN BY								
B. MIDDLETON								

REASON FOR CHANGE (USE ATTACHMENTS IF NECESSARY)

SYMPTOM:  
 VCO CLOCK WILL NOT LOCK ON, CAUSING P.E. PARITY ERRORS

PROBLEM:  
 MARGINAL 74LS74'S FAIL AT LOCATION 5A

SOLUTION:  
 INSTALL AN I.C. SOCKET AT LOCATION 5A

DETAILED DESCRIPTION OF CHANGE TO AFFECTED DOCUMENTS AND/OR PARTS (USE CONTINUATION SHEETS, IF REQ'D, TO SHOW REWORK, SCHEMATIC CHANGES, ASSY CHANGES, B/M CHANGES, ETC.)

1) ON ASSY 60000601

A) INSTALL SOCKET, 14 PIN (P23007008) AT LOCATION 5A

2) ON B/M 60000601 & ASSY DWG.

A) ADD ITEM 120, I.C. SOCKET 14 PIN, LOCATION 5A, P23007008

B) ON ASSY DWG, ADD CALLOUT FOR ITEM 120 AT LOCATION 5A

JUL 16 1981

	CONNECTOR A		CONNECTOR B		CONNECTOR C		CONNECTOR D		CONNECTOR E		CONNECTOR F	
	1	2	1	2	1	2	1	2	1	2	1	2
A					NPGHI-4	+5V-0		+5V-0		+5V-0		+5V-0
B					NPGHO-4							
C		GND-0		GND-0		GND-0		GND-0	A12L-1	GND-0		GND-0
D						D15L-1		BR7L-2	A17L-2	A15L-1	BRSYL-3	
E						D14L-1		BR6L-2	MSYNL-3	A16L-2		
F						D13L-1		BR5L-2	A02L-1	C1L-2		
H					D11L-1	D12L-1		BR4L-2	A01L-1	A00L-1		
J						D10L-1			SSYNL-3	COL-2	NPRL-4	
K						D09L-1		BG7H1-2	A14L-1	A13L-1		
L	SCHEMATIC					D08L-1	INITL-4	BG7H0-2	A11L-1			
M	CONNECTOR					D07L-1		BG6H1-2			INITRL-4	
N	DESIGNATIONS:					D04L-1		BG6H0-2		A08L-1		
P		A T I				D05L-1		BG5H1-2	A10L-1	A07L-1		
R						D01L-1		BG5H0-2	A09L-1			
S						D00L-1		BG4H1-2				
T	GND-0		GND-0		GND-0	D03L-1	GND-0	BG4H0-2	GND-0		GND-0	SACKL-4
U						D02L-1			A06L-1	A04L-1		
V						D06L-1			A05L-1	A03L-1		

INDICATES SCHEMATIC PAGE NUMBER

TC-131 BUS CONNECTIONS

1 = Component Side

2 = Solder Side

3

APPENDIX A

STANDARD TAPE DRIVE  
CABLES AND ADAPTERS

5-12-81

## TABLE OF CONTENTS

TITLE	DRAWING NO.
Modification Drawing, Tape Control Adapter (Config. "S")	112001
Assembly - Cable, Control	121004
Assembly - Cable, Read	121006
Assembly - Cable, Write	121014
Assembly Drawing - Adapter, Tape Read Connector	122005
Assembly Drawing - Tape Write Connector	122006
Assembly, Jumper Array, Select Switch Option	122010
Assembly, Jumper Array, Select Switch Option, Special	122011
Assembly, Jumper Array, Non-Select Switch Option	122012
Assembly Drawing - Adapter, Tape Read, Kennedy, Cipher	122018
Assembly Drawing - Adapter, Tape Write, Kennedy, Cipher	122019
Schematic - Adapter, Tape Write Connector	122021
Schematic - Adapter, Tape Read Connector	122022
Assembly, Adapter, Tape Write, Kennedy 9800	122034
Assembly, Adapter, Tape Read, Kennedy 9800	122035
Schematic - Tape Control Adapter	122036
Assembly - Adapter, Tape Control Connector	122037
Assembly - Adapter, Tape Control Connector, 90° Mounting	122038
Assembly - Adapter, Tape Control Connector, 2-inch Standoff	122039
Assembly - Adapter, Tape Read, Reverse Image, 90°	122043
Modification Drawing, Tape Control Adapter (Config. "N")	122044

## FUNCTIONAL INDEX

	DRAWING NO.
I. RIBBON CABLES AND BACKPLANE CONNECTORS	
Assembly - Cable, Control	121004
Assembly - Cable, Read	121006
Assembly - Cable, Write	121014
II. ADAPTER PADDLEBOARDS	
I. SCHEMATICS	
Schematic - Tape Control Adapter	122036
Schematic - Adapter, Tape Write Connector	122021
Schematic - Adapter, Tape Read Connector	122022
2. ASSEMBLY DRAWINGS	
a. CONTROL	
Assembly - Adapter, Tape Control Connector (Standard)	122037
Assembly - Adapter, Tape Control Connector (90° Mount)	122038
Assembly - Adapter, Tape Control Connector (2-inch Standoff)	122039
b. WRITE	
Assembly Drawing - Tape Write Connector (Standard)	122006
Assembly Drawing - Adapter, Tape Writer (Reverse Image)	122019
Assembly - Adapter, Tape Write (90° Mount)	122034
c. READ	
Assembly Drawing - Adapter, Tape Read Connector	122005
Assembly Drawing - Adapter, Tape Read (Reverse Image)	122018
Assembly - Adapter, Tape Read (90° Mount)	122035
Assembly - Adapter, Tape Read (Reverse Image 90° Mount)	122043
d. DRIVE SELECT JUMPERS	
Assembly, Jumper Array, Select Switch Option	122010
Assembly, Jumper Array, Select Switch Option (4th Drive)	122011
Assembly, Jumper Array, Non-Select Switch Option	122012
III. SPECIAL FEATURE MODIFICATIONS	
Modification Drawing, Tape Control Adapter Configuration "S"	112001
Modification Drawing - Tape Control Adapter Configuration "N"	122044



MANUAL SUPPLEMENTS

MANUAL NO. APPENDIX A STD TAPE DRIVE PRESENT REVISION \_\_\_\_\_

<u>DATE</u>	<u>SUPL. NO.</u>	<u>CHANGE DESCRIPTION</u>	<u>AUTH.</u>
11-26-80		79000410 ADDED	ER
1-7-81		79000642 ADDED	
4-3-81		62000427 Added	ER
5-12-81		79000402 Added	ER

**PURPOSE:**

THIS MODIFICATION REQUIRED FOR CONTROL OF QUANTEX TAPE DRIVES.

REVISIONS			
LTR	DESCRIPTION	DATE	APPROVAL
A	REDRAWN TO CORRECT DETAIL FOR E OR F ARTWORK (REF ECQ 780)	10-2-80	<i>[Signature]</i>

SHEET (2) OF SCHEMATIC 122036 IS ALTERED AS OUTLINED BELOW.

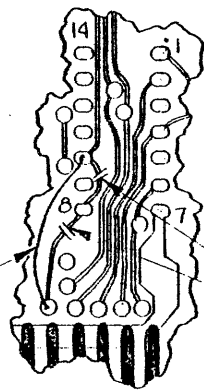
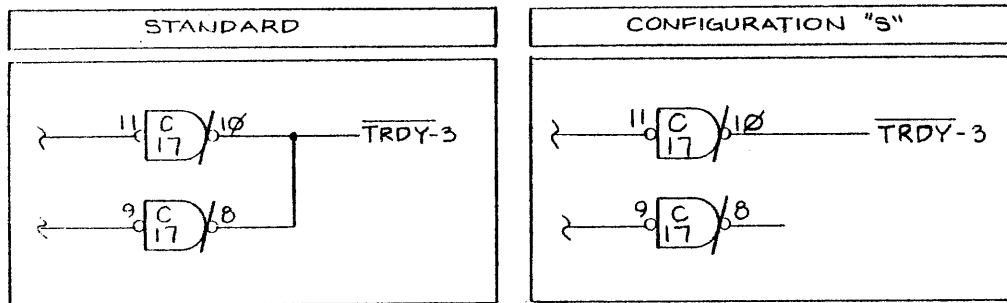

JUMPER

CUT

SOLDER SIDE VIEW  
IC. LOCATION "C"

**REWORK INSTRUCTIONS:**

FOR ASSY: 122037, 122038, 122039

- A). CUT ETCH 2 PLCS AT C-8 (SOLDER SIDE)
- B). ADD JUMPER FROM C-10 TO FEED-THRU ON ETCH THAT WAS CONNECTED TO C-8
- C). IDENTIFY AT ASSY NO. WITH "CONF S" USING BLACK INK.

OCT 2 1980

TOLERANCES UNLESS OTHERWISE SPECIFIED		<b>western peripherals™</b> TUSTIN, CALIFORNIA	
FRACTIONS	DEC	ANGLES	MODIFICATION DWG - TAPE CONT. ADAPTER, CONF "S"
±	±	±	
APPROVALS	DATE	SCALE	SIZE
DRAWN BY <i>[Signature]</i>	10-1-80	✓	B
CHECKED <i>[Signature]</i>	10-2-80		DRAWING NO. 112001
DO NOT SCALE DRAWING			SHEET 1 OF 1

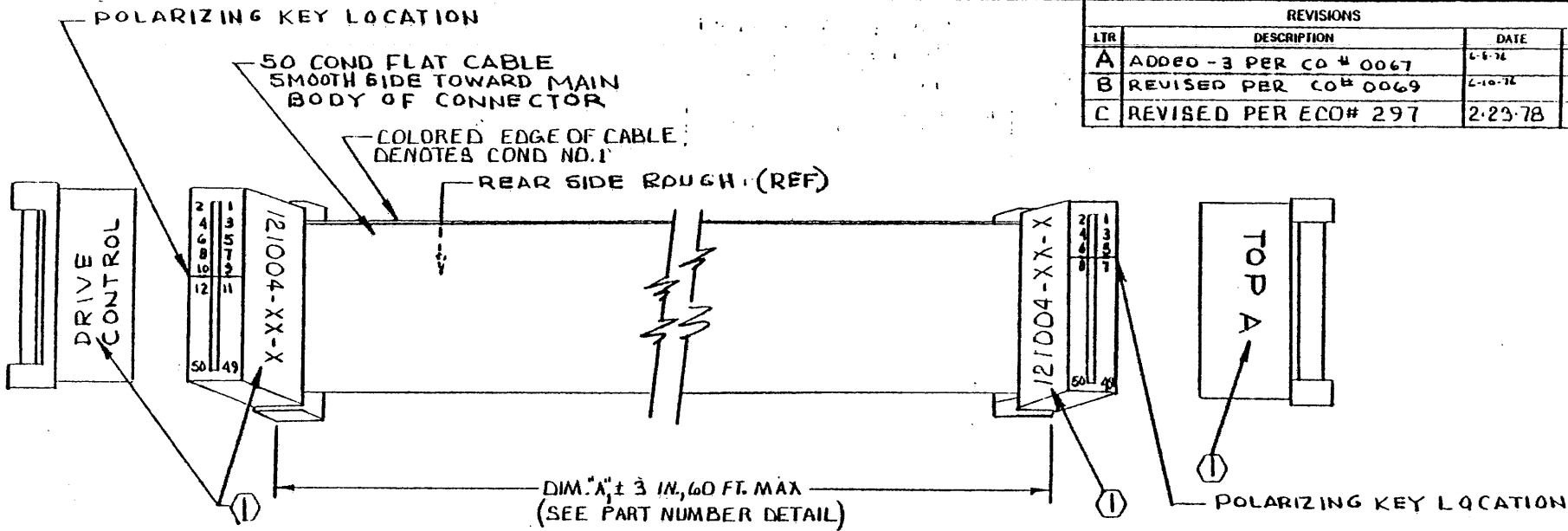

REVISIONS			
LTR	DESCRIPTION	DATE	APPROVED
A	ADDED -3 PER CO # 0067	4-6-76	N.D.
B	REVISED PER CO # 0069	4-10-76	N.D.
C	REVISED PER ECO# 297	2-23-78	N.D., 9-78

NOTES.

- ① MARK CHARACTERS SHOWN USING CONTRASTING COLOR INK.  
SEE PART NUMBER DETAIL FOR MARKING OF VARIABLE CHARACTERS (X's).
- 2. ASSEMBLY:  
USE 3M PRESS NO. 3440  
USE LOCATOR PLATE NO. 3443-11  
USE SETTING NO 9 OF GAUGE 3436-1  
CUT CABLE USING SCOTCHFLEX CABLE SHEAR OR EQUIV.  
SEAT CABLE INTO COVER USING SCOTCHFLEX TOOL NO. 3453. CHECK FOR ALIGNMENT  
PLACE BODY ON LOCATOR PLATE  
POSITION COVER AND CABLE OVER CONN BODY  
LOWER HANDLE TO COMPLETE ASSY  
REMOVE BY LIFTING ON CONNECTOR

PART NUMBER DETAIL

	121004-XX-X
BASIC PART NUMBER _____	
DASH NUMBER IN FEET (REF. DIM. "A") _____	
(-07 FOR 7 FT., -10 FOR 10 FT., ETC.)	
LATEST REVISION LETTER _____	

FOR PARTS SEE PARTS LIST 121004

TOLERANCES UNLESS OTHERWISE SPECIFIED		western peripherals ANAHEIM, CALIFORNIA	
FRACTIONS	DEC.	ANGLES	
±	±	±	
APPROVALS	DATE	ASSEMBLY- CABLE, CONTROL	
DRAWN CORUM	6-1-76		
CHECKED T.D.	6-1-76		
SCALE	SIZE	DRAWING NO.	
NONE	B	121004	
DO NOT SCALE DRAWING			SHEET

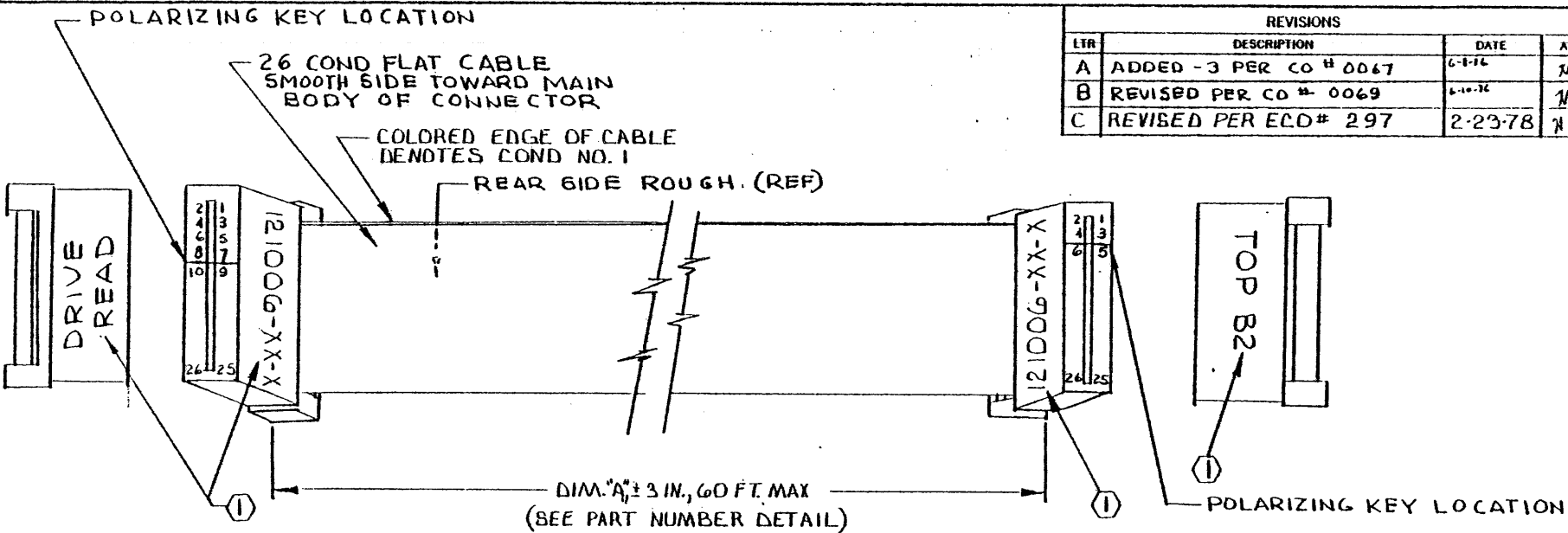

REVISIONS			
LTR	DESCRIPTION	DATE	APPROVED
A	ADDED - 3 PER CO # 0067	6-1-76	J.D.
B	REVISED PER CO # 0069	6-1-76	J.D.
C	REVISED PER ECD# 297	2-23-78	J.D., 9-78

PART NUMBER DETAIL

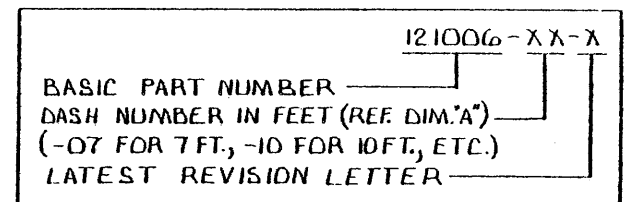

NOTES:

① MARK CHARACTERS SHOWN USING CONTRASTING COLOR INK.  
SEE PART NUMBER DETAIL FOR MARKING OF VARIABLE CHARACTERS (X'S).

2. ASSEMBLY:

- USE 3M PRESS NO 3440
- USE LOCATOR PLATE NO. 3443-11
- USE SETTING NO. 9 OF GAUGE NO. 3436-1
- CUT CABLE USING SCOTCHFLEX CABLE SHEAR OR EQUIV.
- SEAT CABLE INTO COVER USING SCOTCHFLEX TOOL NO 3453, CHECK FOR ALIGNMENT
- PLACE BODY ON LOCATOR PLATE
- POSITION COVER AND CABLE OVER CONN BODY
- LOWER HANDLE TO COMPLETE ASSY
- REMOVE BY LIFTING ON CONNECTOR

FOR PARTS SEE PARTS LIST 121006

TOLERANCES UNLESS OTHERWISE SPECIFIED		<b>western peripherals</b> ANAHEIM, CALIFORNIA	
FRACTIONS	DEC.		
±	±	±	
APPROVALS	DATE	<b>ASSEMBLY CABLE, READ</b>	
DRAWN CORUM	6-1-76		
CHECKED J.D.	6-1-76		
SCALE		SIZE	DRAWING NO.
NONE		B	121006
DO NOT SCALE DRAWING			SHEET

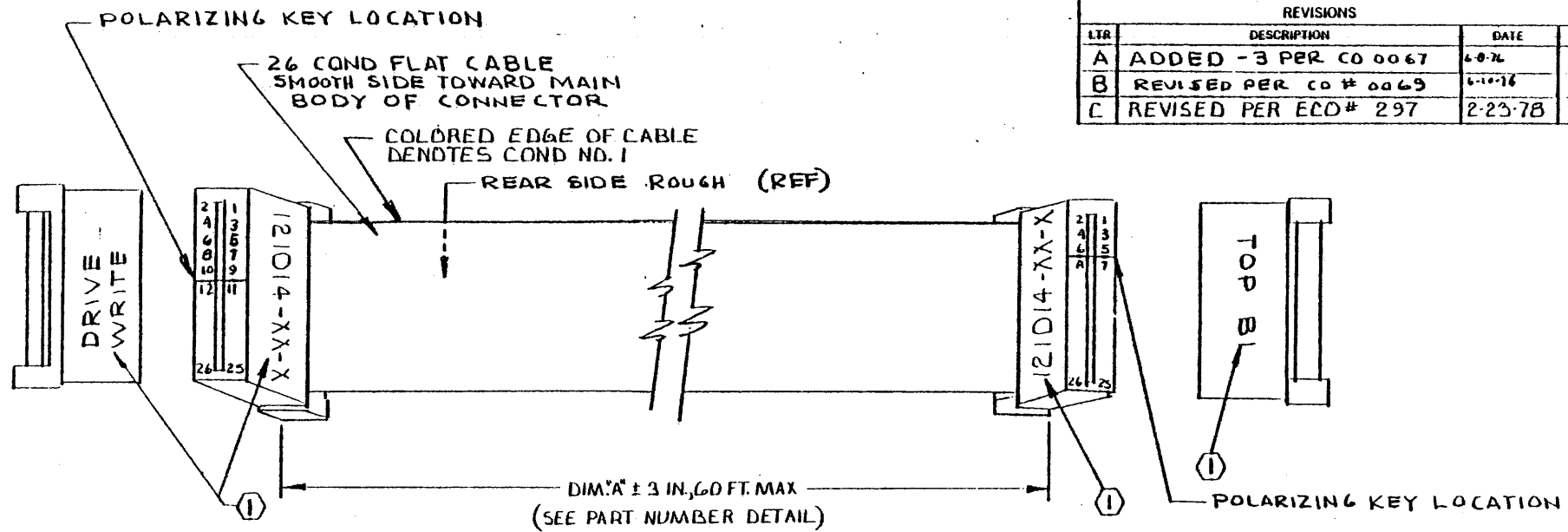

REVISIONS			
LTR	DESCRIPTION	DATE	APPROVED
A	ADDED - 3 PER CO 0067	6-0-76	N.D.
B	REVISED PER CO # 0069	6-10-76	N.D.
C	REVISED PER ECO # 297	2-23-78	N.D., 4-78

PART NUMBER DETAIL

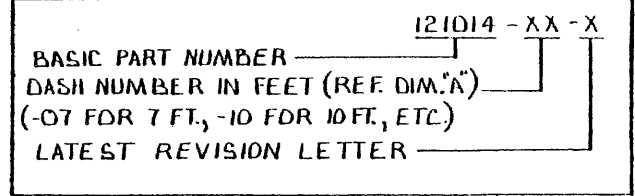

NOTES:

① MARK CHARACTERS SHOWN USING CONTRASTING COLOR INK. SEE PART NUMBER DETAIL FOR MARKING OF VARIABLE CHARACTERS (X's).

2. ASSEMBLY:

- USE 3M PRESS NO. 3440.
- USE LOCATOR PLATE NO 3443-11
- USE SETTING NO 9 OF GAUGE 3436-1
- CUT CABLE USING SCOTCHFLEX CABLE SHEAR OR EQUIV.
- SEAT CABLE INTO COVER USING SCOTCHFLEX TOOL NO 3453, CHECK FOR ALIGNMENT
- PLACE BODY ON LOCATOR PLATE
- POSITION COVER AND CABLE OVER CONN BODY
- LOWER HANDLE TO COMPLETE ASSY
- REMOVE BY LIFTING ON CONNECTOR

FOR PARTS SEE PARTS LIST 121014

TOLERANCES UNLESS OTHERWISE SPECIFIED		 western peripherals ANAHEIM, CALIFORNIA				
FRACTIONS DEC.	ANGLES					
±	±	<b>ASSEMBLY- CABLE, WRITE</b>				
APPROVALS	DATE					
DRAWN C. D. RUM	6-1-76			SCALE NONE	SIZE B	DRAWING NO. 121014
CHECKED N.D.	6-1-76			DO NOT SCALE DRAWING		SHEET

REVISIONS			
LTR	DESCRIPTION	DATE	APPROVED
A	REV PER CONO. 0105	9-8-76	
B	E.C.O NO.-0190	6-6-77	J.D. 11-77
C	REVISED NOTE 2 PER ECO.#415	2/2/79 J.D.	2/4/79 J.C.
D	ADDED NOTE (4) PER ECO# 504	6-20-79 E.	4/11/80 J.C.

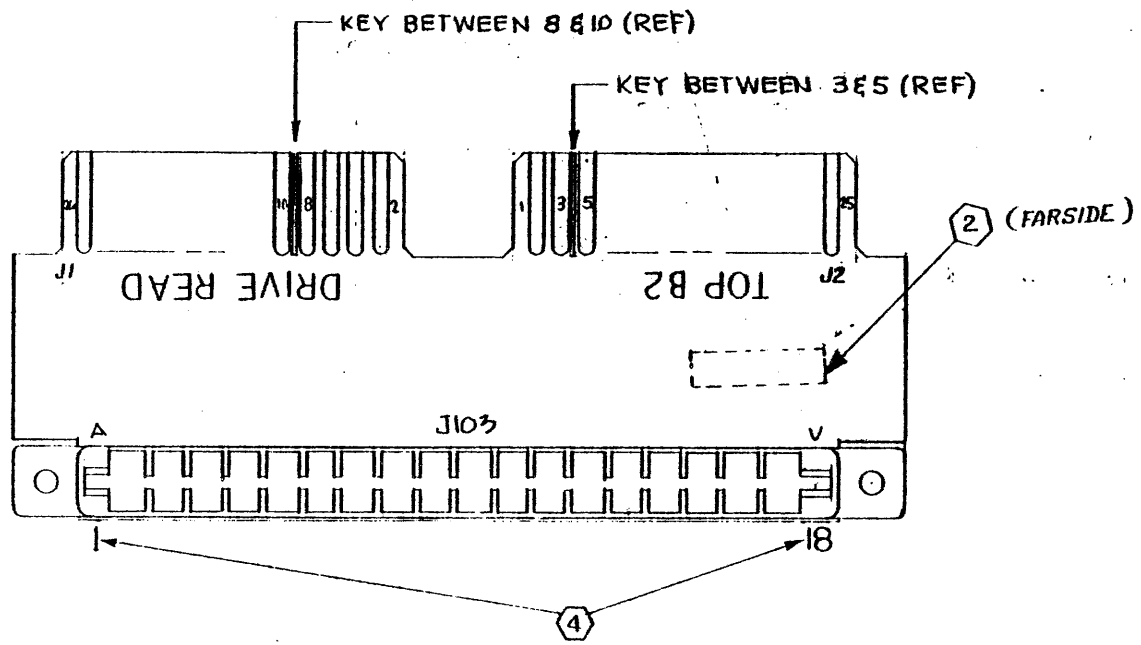

NOTE.

1. REF SCHEMATIC DWG NO. 122022
2. RUBBER STAMP ASY NO. WITH LATEST REV. LTR AFFIX WHERE SHOWN USING BLK INK.
3. FOR MATL SEE P/L 122005
4. MARK CHARACTERS SHOWN (1&18) ON SIDE OF CONNECTOR USING CONTRASTING INK.

COPYRIGHT © 1976 BY WESTERN PERIPHERALS, INC.

TOLERANCES UNLESS OTHERWISE SPECIFIED		<b>western peripherals</b> <small>ANAHEIM, CALIFORNIA</small>	
FRACTIONS	DEC.		
±	±	±	<b>ASSEMBLY DWG.</b> <b>ADAPTER, TAPE READ</b> <b>CONNECTOR</b>
APPROVALS	DATE	SCALE	
DRAWN <i>HEB</i>	2-13-76	2:1	
CHECKED <i>at</i>	2-25-76	SIZE <b>B</b>	
			DRAWING NO. <b>122005</b>
			DO NOT SCALE DRAWING
			SHEET 1 OF 1

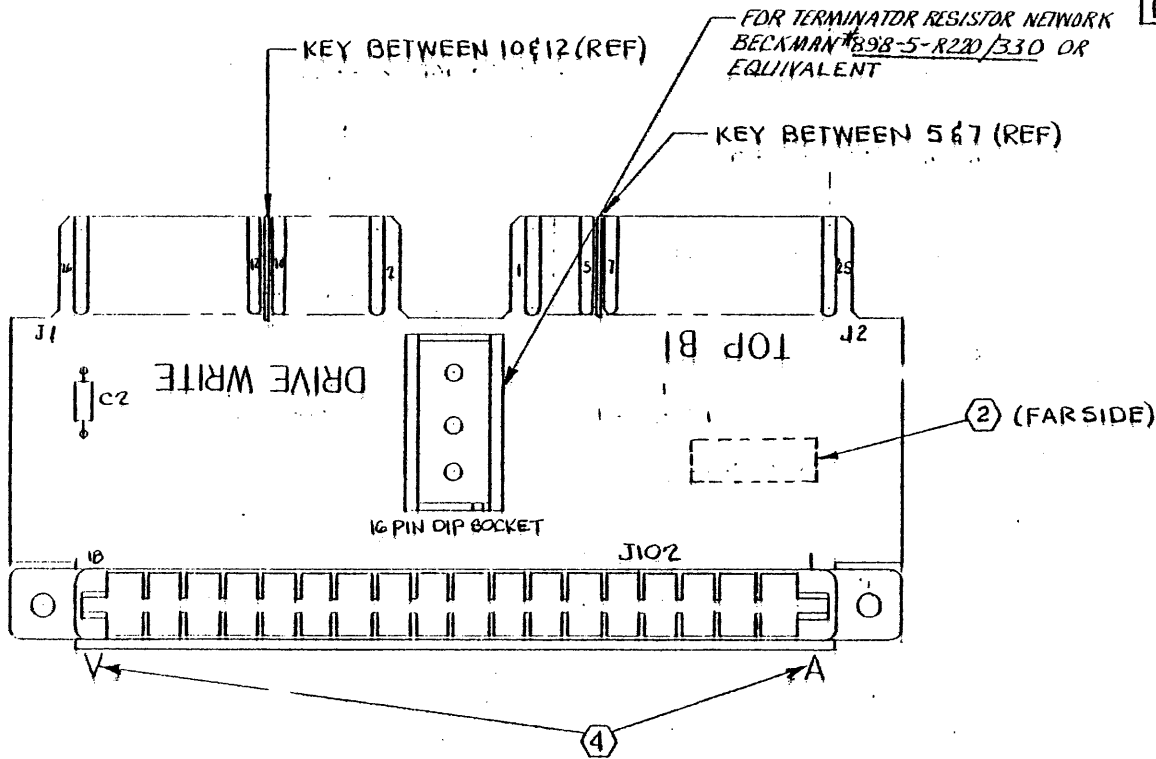

REVISIONS			
LTR	DESCRIPTION	DATE	APPROVED
A	E.C.O. NO.-0190	6-6-77	W.D. 6-11-77
B/C	ADVANCED REV LTR TO AGREE WITH F/L	2/1/79	W.H.N. 2-6-79
D	REVISED NOTE 2 PER ECO# 416	2/1/79	W.H.N. 2-6-79
E	ADDED NOTE (4) PER ECO# 504	6-20-79	W.D. 6-20-79

**NOTE:**

1. REF SCHEMATIC DWG. NO. 122021.
- (2) RUBBER STAMP ASSY NO. WITH LATEST REV LTR APPROX. WHERE SHOWN USING BLK INK.
3. FOR MATL SEE P/L 122006.
- (4) MARK CHARACTERS SHOWN (A&V) ON SIDE OF CONNECTOR USING CONTRASTING INK.

COPYRIGHT © 1976 BY WESTERN PERIPHERALS, INC.

TOLERANCES UNLESS OTHERWISE SPECIFIED		 western peripherals ANAHEIM, CALIFORNIA	
FRACTIONS	DEC.		
±	±	±	<b>ASSEMBLY DWG.</b> <b>ADAPTER, TAPE WRITE</b> <b>CONNECTOR</b>
APPROVALS	DATE	SCALE	
DRAWN HRB	2-12-76	2:1	
CHECKED WZ	2-25-76	SIZE B	DRAWING NO. 122006
		DO NOT SCALE DRAWING	SHEET 1 OF 1

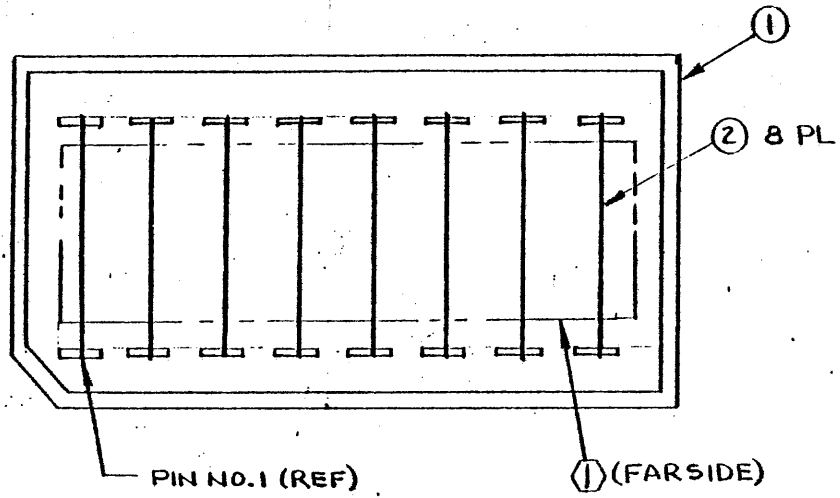

REVISIONS			
LTR	DESCRIPTION	DATE	APPROVED

WIRE NO.	FROM PIN NO.	TO PIN NO.
1	1	16
2	2	15
3	3	14
4	4	13
5	5	12
6	6	11
7	7	10
8	8	9

NOTE: UNLESS OTHERWISE SPECIFIED  
 ① AFFIX ADHESIVE LABEL WITH PART NO. & LATEST REV LTR WHERE SHOWN

**BILL OF MATERIALS**

ITEM	NO. REQD	PART NO.	DESCRIPTION	REMARKS
1	1	CA-16P-12	DIP PLUG, 16 PIN	CIRCUIT ASSY. OR EQUIV.
2	A/R		WIRE, INSULATED, #30 AWG SOLID	WIRE WRAP WIRE

TOLERANCES UNLESS OTHERWISE SPECIFIED	
FRACTIONS	DEC. ANGLES
±	± ±
APPROVALS	DATE
DRAWN CORUM	11-18-76
CHECKED W.D.	11-18-76

**western peripherals**  
 ANAHEIM, CALIFORNIA

**ASSY, JUMPER ARRAY, SELECT SWITCH OPTION**

SCALE	SIZE	DRAWING NO.
NONE	B	122010

DO NOT SCALE DRAWING      SHEET 1 OF 1



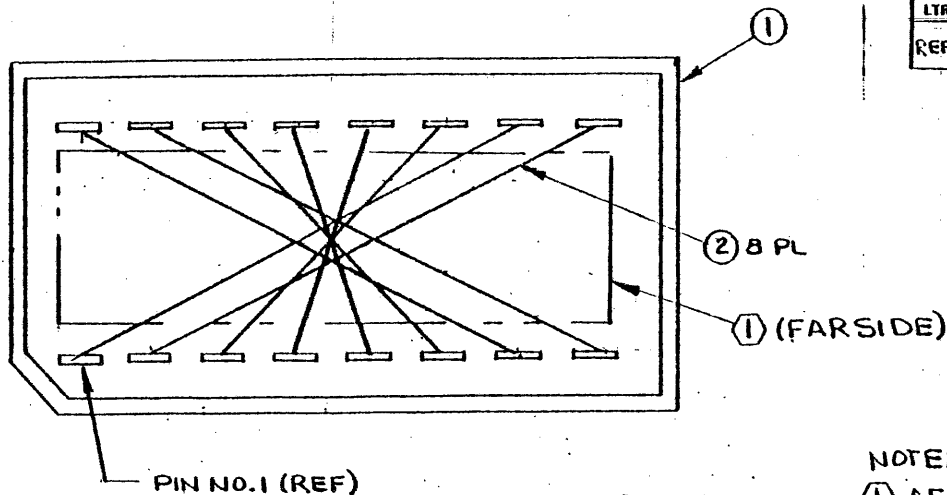

REVISIONS			
LTR	DESCRIPTION	DATE	APPROVED
REF	REC. CHG: ADD FARSIDE TO (1) (ALL PARTS MADE CONFORM)		

WIRE LIST		
WIRE NO.	FROM PIN NO.	TO PIN NO.
1	1	10
2	2	9
3	3	11
4	4	12
5	5	13
6	6	14
7	7	16
8	8	15

NOTE: UNLESS OTHERWISE SPECIFIED  
 (1) AFFIX ADHESIVE LABEL WITH PART NO. &  
 LATEST REV LTR WHERE SHOWN

**BILL OF MATERIALS**

ITEM	NO. REQD	PART NO.	DESCRIPTION	REMARKS
1	1	CA-16P-12	DIP PLUG, 16-PIN	CIRCUIT ASSY OR EQUIV
2	A/R		WIRE, INSULATED, #30 AWG SOLID	WIRE WRAP WIRE

TOLERANCES UNLESS OTHERWISE SPECIFIED		western peripherals ANAHEIM, CALIFORNIA	
FRACTIONS	DEC.		
±	±	±	<b>ASSY, JUMPER ARRAY,          SELECT SWITCH OPTION,          SPECIAL (4TH TRANSPORT)</b>
APPROVALS	DATE	SCALE	
DRAWN CORUM	11-18-76	NONE	
CHECKED V.D.	11-18-76	SIZE B	
		DRAWING NO. 122011	
DO NOT SCALE DRAWING			SHEET 1 OF 1

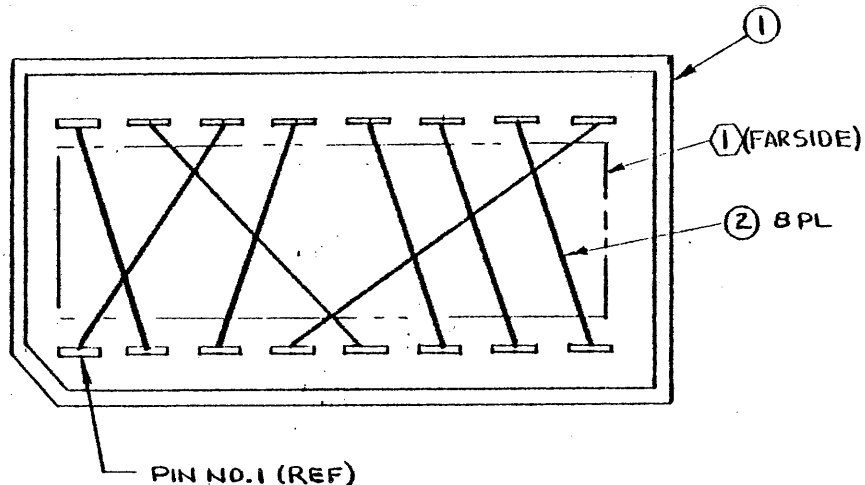

WIRE LIST		
WIRE NO.	FROM PIN NO.	TO PIN NO.
1	1	14
2	2	16
3	3	13
4	4	9
5	5	15
6	6	12
7	7	11
8	8	10

**BILL OF MATERIALS**

ITEM	NO. REQD	PART NO.	DESCRIPTION	REMARKS
1	1	CA-16P-12	DIP PLUG, 16-PIN	CIRCUIT ASSY OR EQUIV
2	A/R		WIRE, INSULATED, #30 AWG SOLID	WIRE WRAP WIRE

REVISIONS			
LTR	DESCRIPTION	DATE	APPROVED

NOTE: UNLESS OTHERWISE SPECIFIED  
 ① AFFIX ADHESIVE LABEL WITH PART NO. & LATEST REV LTR WHERE SHOWN

TOLERANCES UNLESS OTHERWISE SPECIFIED FRACTIONS DEC. ANGLES ± ± ±		 western peripherals ANAHEIM, CALIFORNIA	
APPROVALS		DATE	
DRAWN CORUM		11-18-76	
CHECKED J.D.		11-18-76	
SCALE NONE		SIZE B	DRAWING NO. 122012
DO NOT SCALE DRAWING			SHEET 1 OF 1

REVISIONS			
LIR	DESCRIPTION	DATE	APPROVED
A	INCORP. CO # 0145 <sup>772</sup>	1-21-77	N.D. 1-24-77
B	E.C.O. NO. - 0190	6-6-77	N.D. 6-11-77
C	DELETED NOTE 2 PER E.C.O. #417	11/1/79	7/17/79 3-879
D	ADDED NOTE ⑤ PER ECO #504	6-20-79	6/21/79 2079

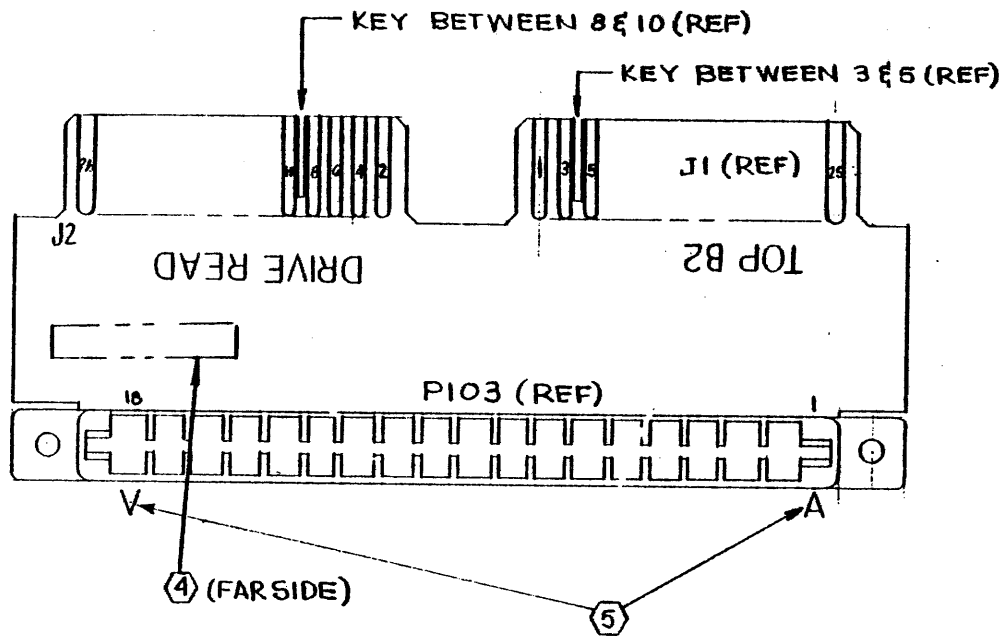

- NOTE: UNLESS OTHERWISE SPECIFIED
1. REF SCHEMATIC DWG NO. 122022
  - 2.
  3. FOR MATERIAL SEE P/L 122018
  - ④ RUBBER STAMP ASSY NO. WITH LATEST REV LTR APPROX WHERE SHOWN USING BLK INK.
  - ⑤ MARK CHARACTERS SHOWN (A&V) ON SIDE OF CONNECTOR USING CONTRASTING INK.

TOLERANCES UNLESS OTHERWISE SPECIFIED		<b>western peripherals</b> ANAHEIM, CALIFORNIA	
FRACTIONS	DEC.		
±	±	±	<b>ASSEMBLY DWG.</b> <b>ADAPTER, TAPE READ</b> <b>KENNEDY-CIPHER</b>
APPROVALS	DATE		
DRAWN HRB	2-15-76	SCALE 2:1	SIZE B
CHECKED [Signature]	2-25-76	DRAWING NO. 122018	
		DO NOT SCALE DRAWING	SHEET 1 OF 1

COPYRIGHT © 1976 BY WESTERN PERIPHERALS, INC.

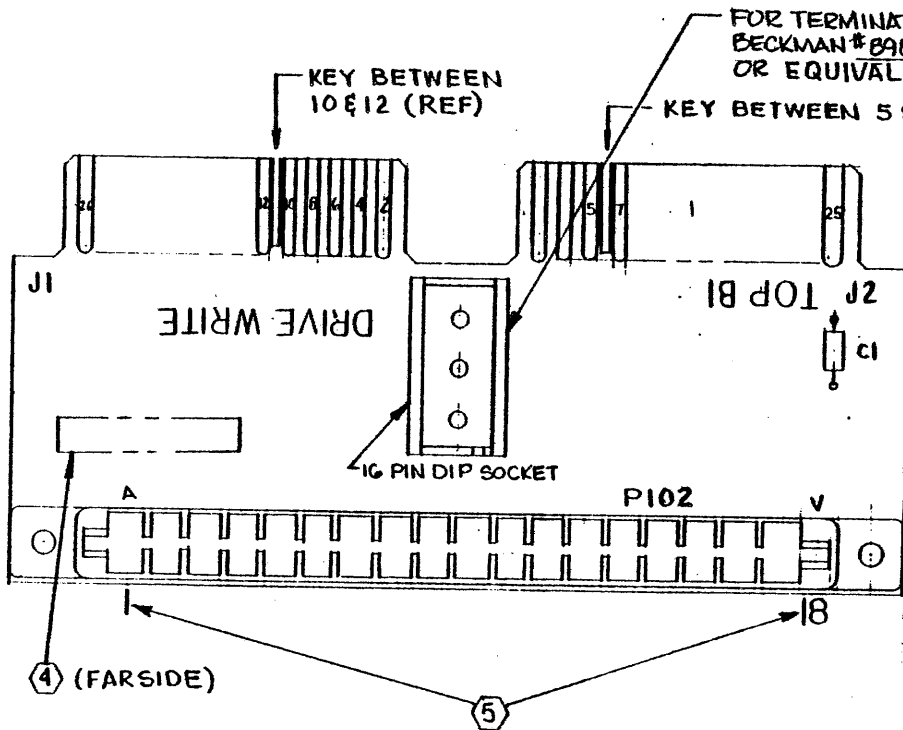

REVISIONS			
LTR	DESCRIPTION	DATE	APPROVED
A	INCORPORATE CO # 0146	1-21-77	H.D. 1-24-77
B	INCORP. ECO 172	5/11/77	H.D. 5-11-77
C	INCORP. ECO. NO. -0190	6-6-77	H.D. 6-11-77
D	DELETED NOTE 2 & CALLOUT PER ECO 418	11/24/79	24477 L-19
E	ADDED NOTE (5) PER ECO # 504	6-20-79	6-20-79

- NOTE: UNLESS OTHERWISE SPECIFIED
- REF SCHEMATIC DWG NO. 122021
  - 
  - FOR MATERIAL SEE P/L 122019
  - RUBBER STAMP ASSY NO. WITH LATEST REV LTR APPROX WHERE SHOWN
  - MARK CHARACTERS (1 & 18) ON SIDE OF CONNECTOR USING CONTRASTING INK.

TOLERANCES UNLESS OTHERWISE SPECIFIED FRACTIONS DEC. ANGLES ± ± ±		 western peripherals ANAHEIM, CALIFORNIA	
APPROVALS		DATE	
DRAWN HRB		2-12-76	
CHECKED RL		2-15-76	
SCALE		2:1	SIZE B
		DRAWING NO. 122019	
DO NOT SCALE DRAWING			SHEET OF

COPYRIGHT © 1976 BY WESTERN PERIPHERALS, INC.

DAISY-CHAIN TO NEXT TAPE DRIVE

B INCORP ECO172		5/11/77	REVISIONS	
C IDENTIFIED SIGNALS AND CONNECTORS PER ELO 709		9-18-80	LTR	DESCRIPTION
			A	ECO-0147
			DATE	APPROVED
			3-30-77	N.D.

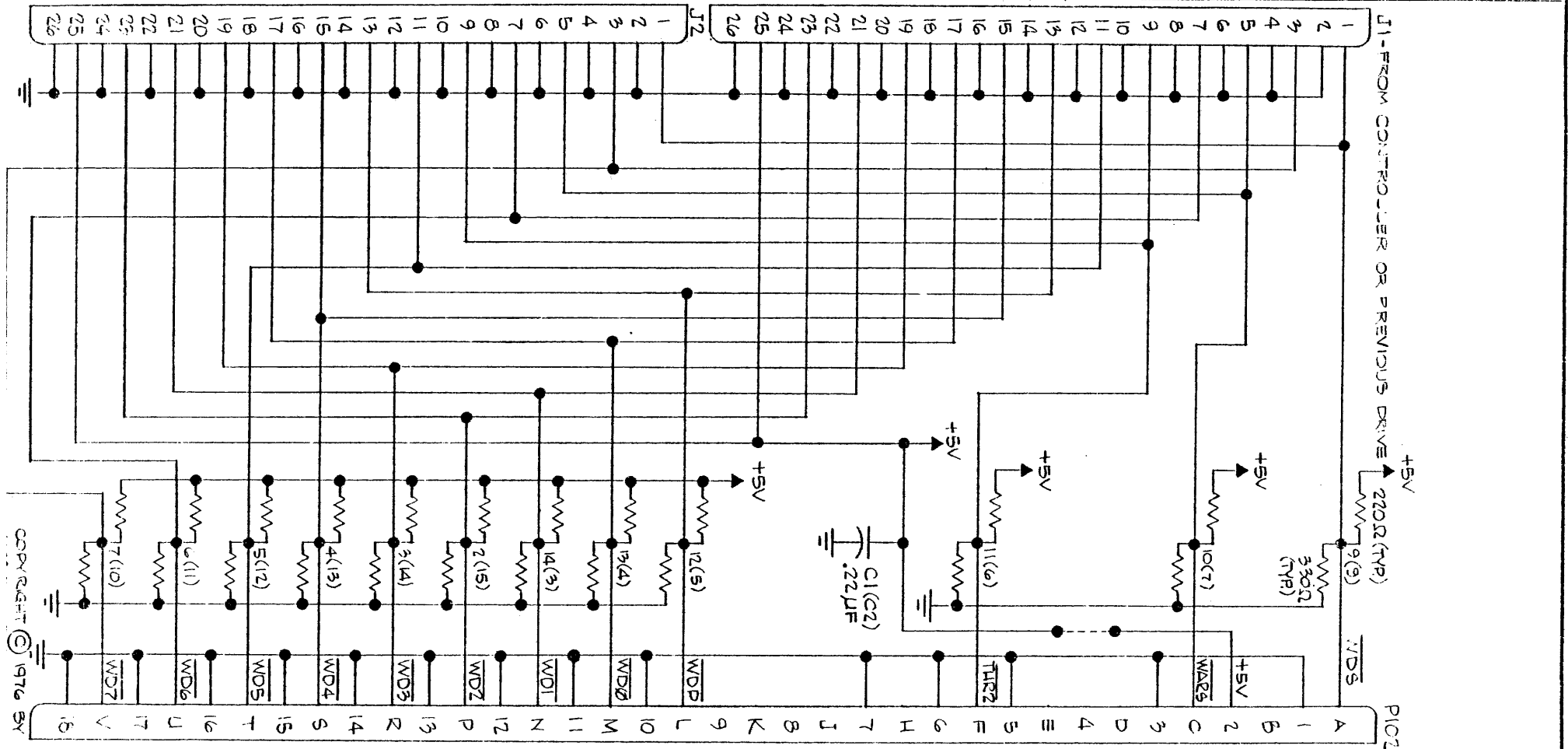

COPYRIGHT © 1976 BY

TO  
TAPE  
DRIVE

NOTES:

1. NEXT ASSY. NO. 122006, 122019, 122021, 122019.
2. PIN NUMBERS AND REFERENCE DESIGNATIONS SHOWN IN PARENTHESES APPLY TO ASSY. 122006, 122034.

TOLERANCES UNLESS OTHERWISE SPECIFIED			<b>western peripherals</b> ANAHEIM, CALIFORNIA	
FRACTIONS	DEC.	ANGLES		
±	±	±	SCHEMATIC ADPTR., TAPE WRITE CONNECTOR	
APPROVALS	DATE	SCALE		
DRAWN HRP	1-12-76	NONE	SIZE B	DRAWING NO. 122021
CHECKED [Signature]	1-26-76	DO NOT SCALE DRAWING	SHEET 1 OF 1	

REVISIONS			
LTR	DESCRIPTION	DATE	APPROVED
A	IDENTIFIED SIGNALS AND CONNECTORS PER ECO 769	9-18-80	

DAISY-CHAIN TO NEXT TAPE DRIVE

PI-FROM CONTROLLER OF PREVIOUS DRIVE

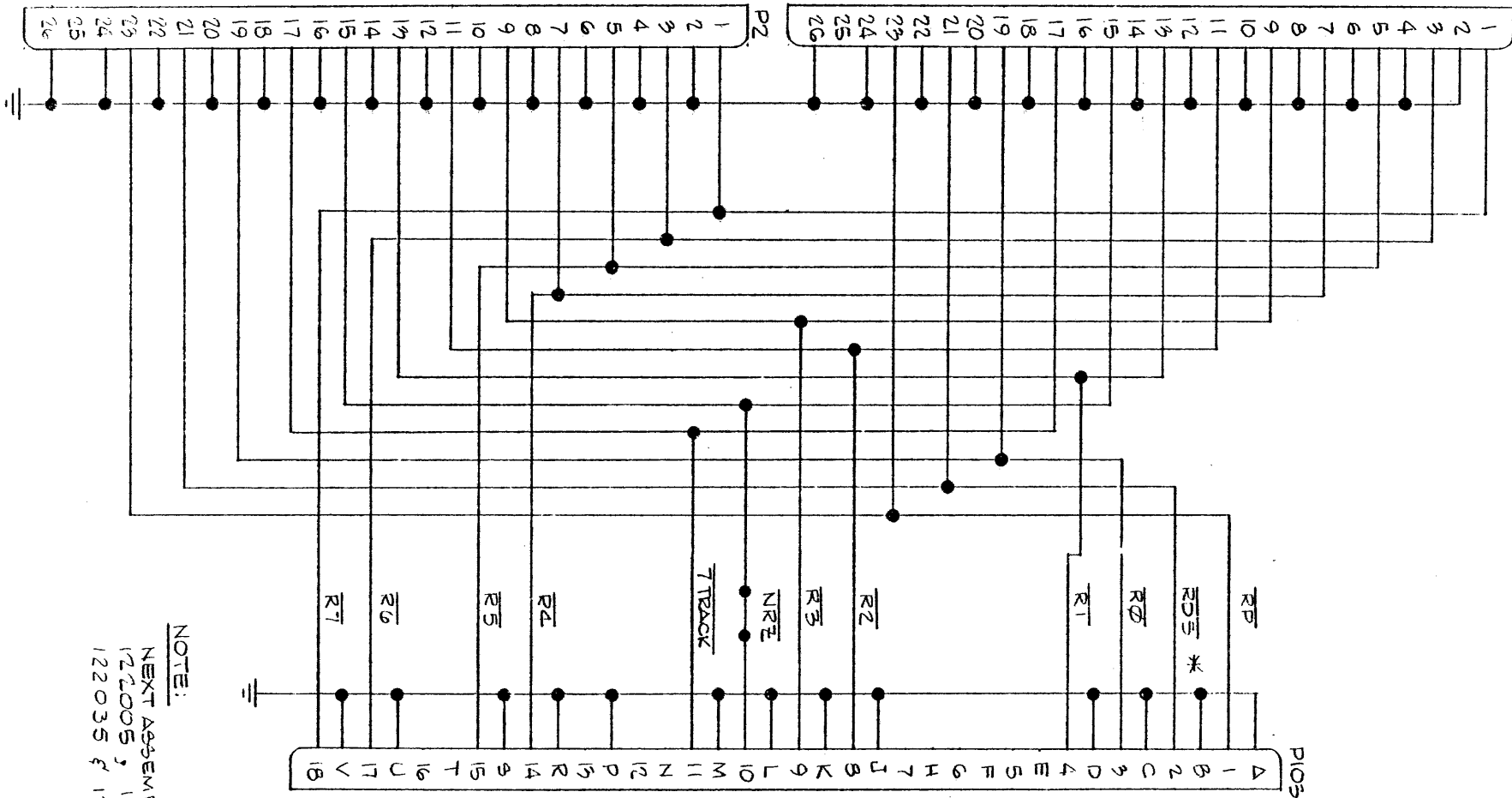

NOTE:

NEXT ASSEMBLY NO.  
122008, 122018,  
122035 & 122043.

TOLERANCES UNLESS OTHERWISE SPECIFIED  
FRACTIONS DEC. ANGLES  
± ± ±



**SCHEMATIC  
ADPTR., TAPE READ  
CONNECTOR**

APPROVALS	DATE
DRAWN HRB	1-13-76
CHECKED <i>[Signature]</i>	1-26-76

SCALE NONE	SIZE B	DRAWING NO. 122022
DO NOT SCALE DRAWING		SHEET 1 OF 1

MEMORANDUM (M) 1071, RV WEATHER, OBTAINED FROM A TUN

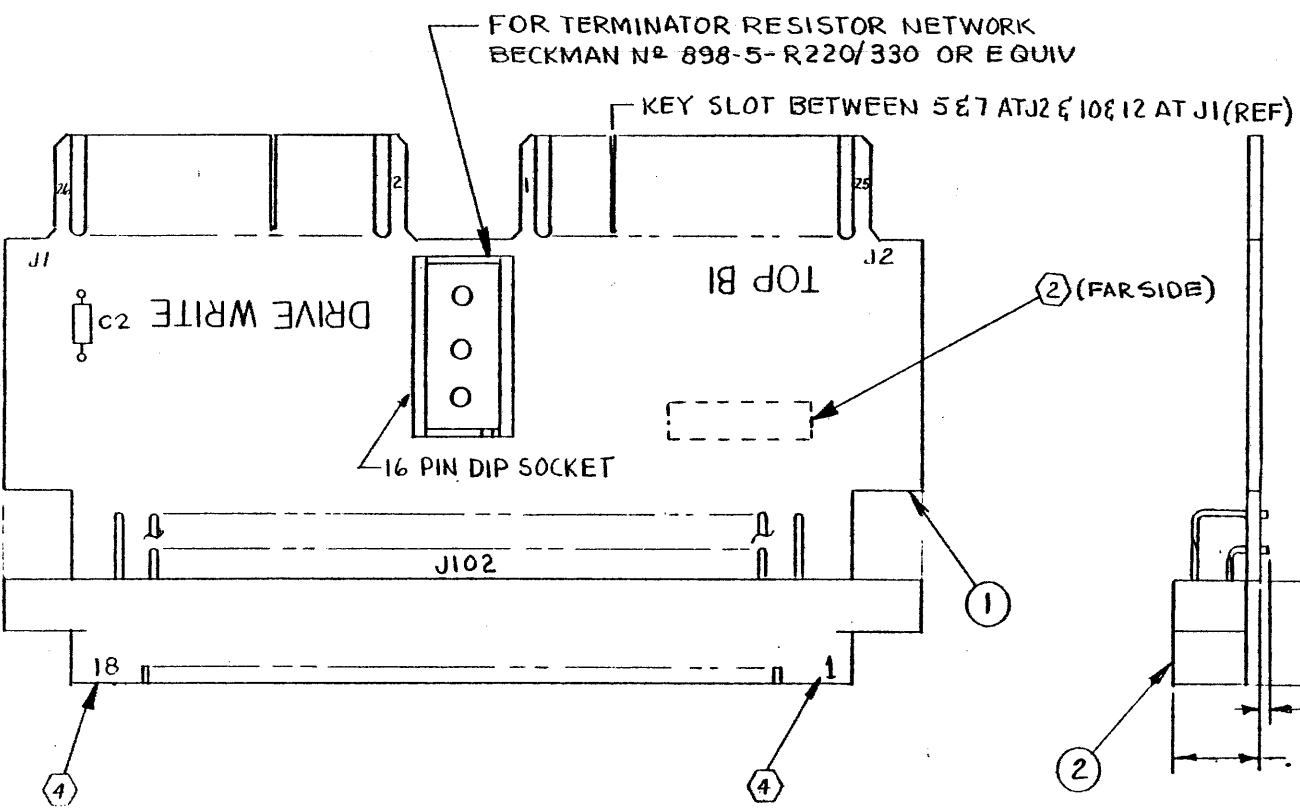

REVISIONS			
LTR	DESCRIPTION	DATE	APPROVED
A	INCRP ECO 172	5/11/77	J.S. 5-11-77
B	INCRP. E.C.O. NO. 0190	6-6-77	J.S. 6-11-77
C	INCRP. E.C.O. NO. 0197	8-8-77	J.S. 8-11-77
D	ADD NOTE 4 PER ECO 355	3/15/78	J.S. 3-15-78
E	ADVANCE REV LTR TO AGREE WITH P/L	1/18/79	J.S. 1-18-79
F	CHANGED NOTE 2 PER ECO 416	2/14/79	J.S. 2-14-79
G	INC ECO # 852 AND CHG ASSY NO. LOCATION	7/10/81	J.S. 7-10-81

- (1) RUBBER STAMP CHARACTERS SHOWN USING WHITE INK.
  - 3. FOR MATERIAL LIST SEE P/L 122034.
  - (2) RUBBER STAMP ASSY NO. & LATEST REV LTR APPROX WHERE SHOWN USING BLK INK.
  - 1. REF. SCHEMATIC DWG NO. 122021.
- NOTE : UNLESS OTHERWISE SPECIFIED.

MAR 27 1981

TOLERANCES UNLESS OTHERWISE SPECIFIED FRACTIONS DEC. ANGLES		 western peripherals ANAHEIM, CALIFORNIA	
±	±		
APPROVALS	DATE	<b>ASSEMBLY- ADAPTER TAPE WRITE KENNEDY 9800</b>	
DRAWN CORUM	6-11-76		
CHECKED			
SCALE 2X	SIZE B	DRAWING NO. 122034	
DO NOT SCALE DRAWING		SHEET 1 OF 1	

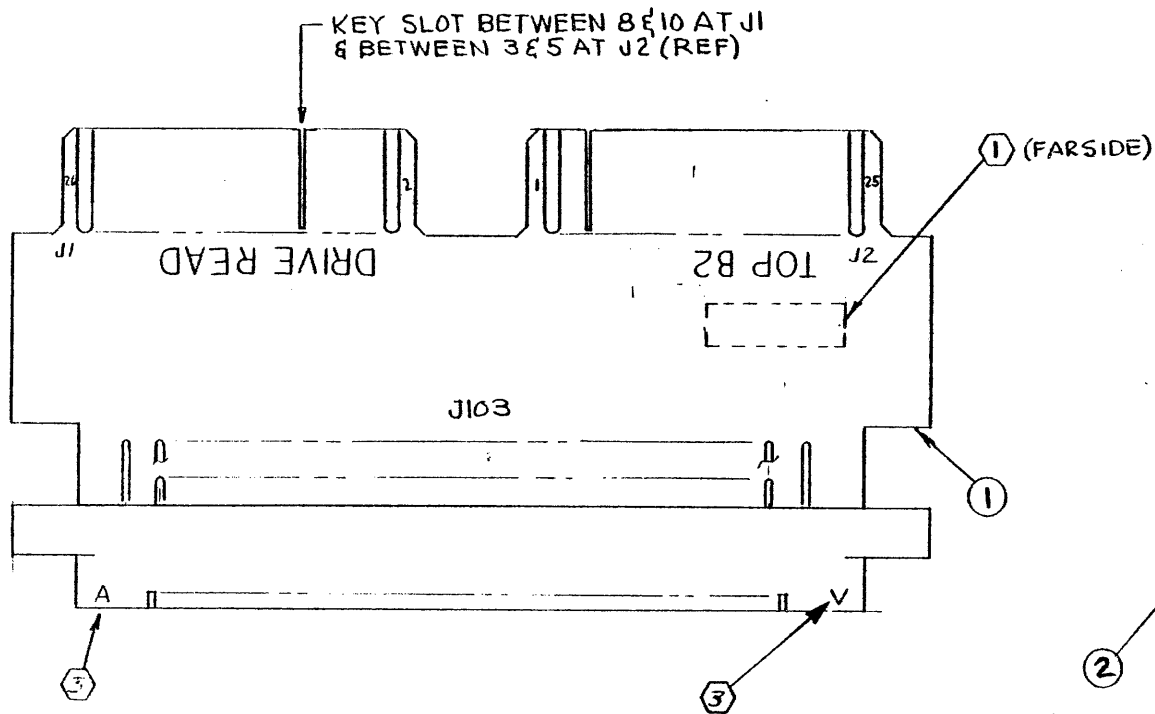

REVISIONS			
LTR	DESCRIPTION	DATE	APPROVED
A	E.C.O. NO-0190	6-6-77	N.P. 6-11-77
B	E.C.O. NO-0197	8-8-77	N.P. 8-9-77
C	ADDED NOTE 3 PER ECO #355	11/2/77	11/2/77
D	ADVANCED REV LTR TO AGREE WITH P/L	11/2/77	11/2/77
E	CHANGED NOTE 1 PER ECO #415	11/2/77	11/2/77
F	INC ECO # 852	11/2/77	11/2/77

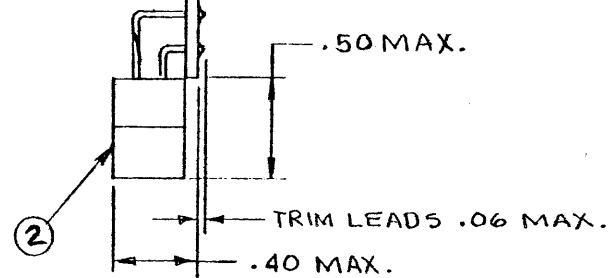

MAR 27 1981

(3) RUBBER STAMP CHARACTERS SHOWN USING WHITE INK.  
 2. REF SCHEMATIC DWG NO. 122022.  
 (1) RUBBER STAMP ASSY NO. & LATEST REV LTR APPROX WHERE SHOWN USING BLK INK.  
 NOTE: UNLESS OTHERWISE SPECIFIED.

TOLERANCES UNLESS OTHERWISE SPECIFIED		 western peripherals ANAHEIM, CALIFORNIA	
FRACTIONS	DEC. ANGLES		
± ± ±	± ± ±	ASSEMBLY-ADAPTER TAPE READ KENNEDY 9800	
APPROVALS	DATE	SCALE	DRAWING NO.
DRAWN CORUM	6-11-76	2 X	B 122035
CHECKED Mc		SIZE	SHEET 1 OF 1
		DO NOT SCALE DRAWING	



REVISIONS			
LTR	DESCRIPTION	DATE	APPROVED
A	CORRECTED SWITCH SETTING CHART FOR SA4 PER ECO 178.	5-4-77	
B	REDRAWN PER ECO 236.	5-16-78	<i>N.D.</i>
C	CHANGED I.C. LOC. H PER ECO 806	12-9-78	<i>N.D.</i>

SWITCH A	SWITCH SETTINGS	SYSTEM CONSIDERATIONS
1	ON FOR DRIVES THAT REQUIRE REWIND COMMAND REMOVAL PRIOR TO BOT	1. REMOVE ALL INTERFACE TERMINATORS FROM TRANSPORT(S) 2. INSTALL CONTROL TERMINATOR ONLY IN LAST DAISY CHAIN POSITION
	OFF FOR DRIVES THAT DO NOT REQUIRE REWIND COMMAND REMOVAL PRIOR TO BOT	
2	ON FOR DRIVES THAT STORE EOT STATUS NOTE: A5 SHOULD BE OFF	3. CORRECTLY IDENTIFY CONFIGURATION AND SET SWITCHES ACCORDINGLY
	OFF FOR DRIVES THAT DO NOT STORE EOT STATUS NOTE: A5 SHOULD BE ON	
3	ON FOR 7 TRACK DRIVES	NOTES: 1. FOR 7 TRACK DRIVES IN DRIVE DAISY CHAINS, ONLY PRIMARY SPEED SELECTION IS AVAILABLE. 2. REF. ASSY. DWG. 122037, 122038, & 122039. ③ 122010 INSTALLED WHEN TRANSPORT HAS 4- POSITION UNIT SELECT SWITCH (SEE EXCEPTION BELOW). 122011 INSTALLED IN 4 <sup>TH</sup> TRANSPORT IF MORE THAN 4 TRANSPORTS ARE DAISY CHAINED. 122012 INSTALLED WHEN TRANSPORT DOES NOT HAVE UNIT SELECT SWITCH. ④ FOR PERTEC COMPATIBLE UNIT SELECT OPTION: JUMPER E TO F, G TO H, AND M TO N. ⑤ FOR EXTERNALLY CONNECTED UNIT SELECT SWITCH: CUT ETCH BETWEEN P & R AND CONNECT EXTERNAL SWITCH TO A, B, C, D, & L. ⑥ TO POWER ADAPTER FROM TAPE TRANSPORT, CUT ETCH BETWEEN J & S AND JUMPER J TO K. 7. FOR CONFIGURATION "L" SEE DWG. 130047. 8. FOR CONFIGURATION "N" SEE DWG. 122044. 9. FOR CONFIGURATION "S" SEE DWG. 112001.
	OFF FOR 9 TRACK DRIVES	
4	ON FOR 7 TRACK 556/800 BPI DENSITY SELECTIONS OR 9 TRACK SECONDARY SPEED (SELECTION B)	
	OFF FOR 7 TRACK 200/556 BPI DENSITY SELECTIONS OR 9 TRACK PRIMARY SPEED (SELECTION A)	
5	ON FOR DRIVES THAT DO NOT STORE EOT STATUS NOTE: A2 SHOULD BE OFF	
	OFF FOR DRIVES THAT STORE EOT STATUS NOTE: A2 SHOULD BE ON	
6	ON FOR 9 TRACK NRZI ONLY DRIVE	
	OFF FOR 7 TRACK DRIVES, 9 TRACK 1600 BPI DRIVES, OR 9 TRACK 800/1600 DUAL DENSITY	
7	ON FOR DUAL DENSITY 9 TRACK DRIVES THAT DO NOT PRESENT NRZ STATUS ON DRIVE READ CONNECTOR	
	OFF FOR DUAL DENSITY 9 TRACK DRIVES THAT DO PRESENT NRZ STATUS ON DRIVE READ CONNECTOR	
8	ON FOR 7 TRACK DRIVES	
	OFF FOR 9 TRACK DRIVES	

TOLERANCES UNLESS OTHERWISE SPECIFIED FRACTIONS DEC. ANGLES ± ± ±		 <b>western peripherals</b> ANAHEIM, CALIFORNIA		
APPROVALS DATE DRAWN T.M. 2-1578				<b>SCHEMATIC</b> <b>TAPE CONTROL ADAPTER</b>
CHECKED N.D.	5-14-78	SCALE	SIZE <b>B</b>	
DO NOT SCALE DRAWING			SHEET 1 OF 3	

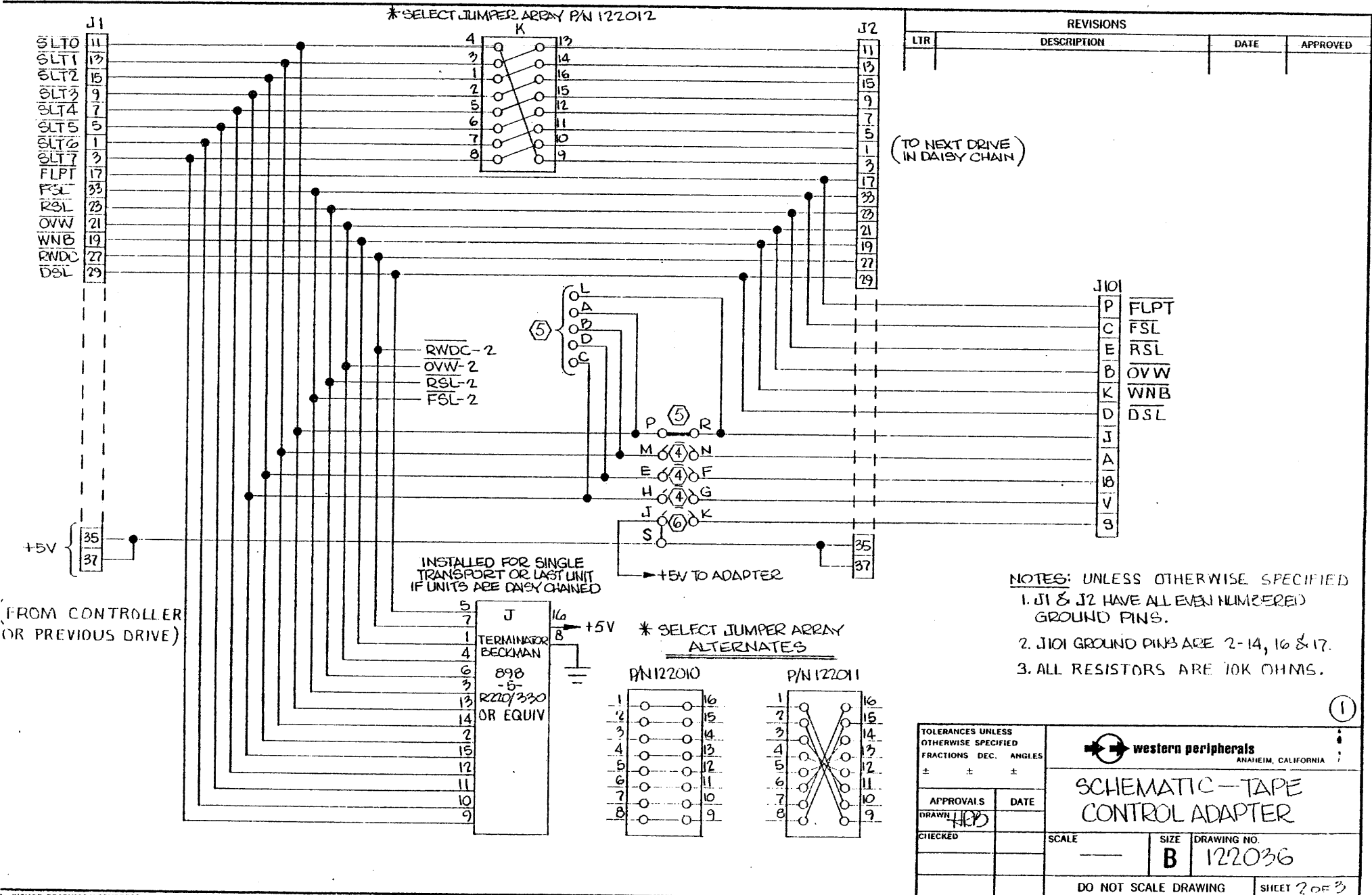

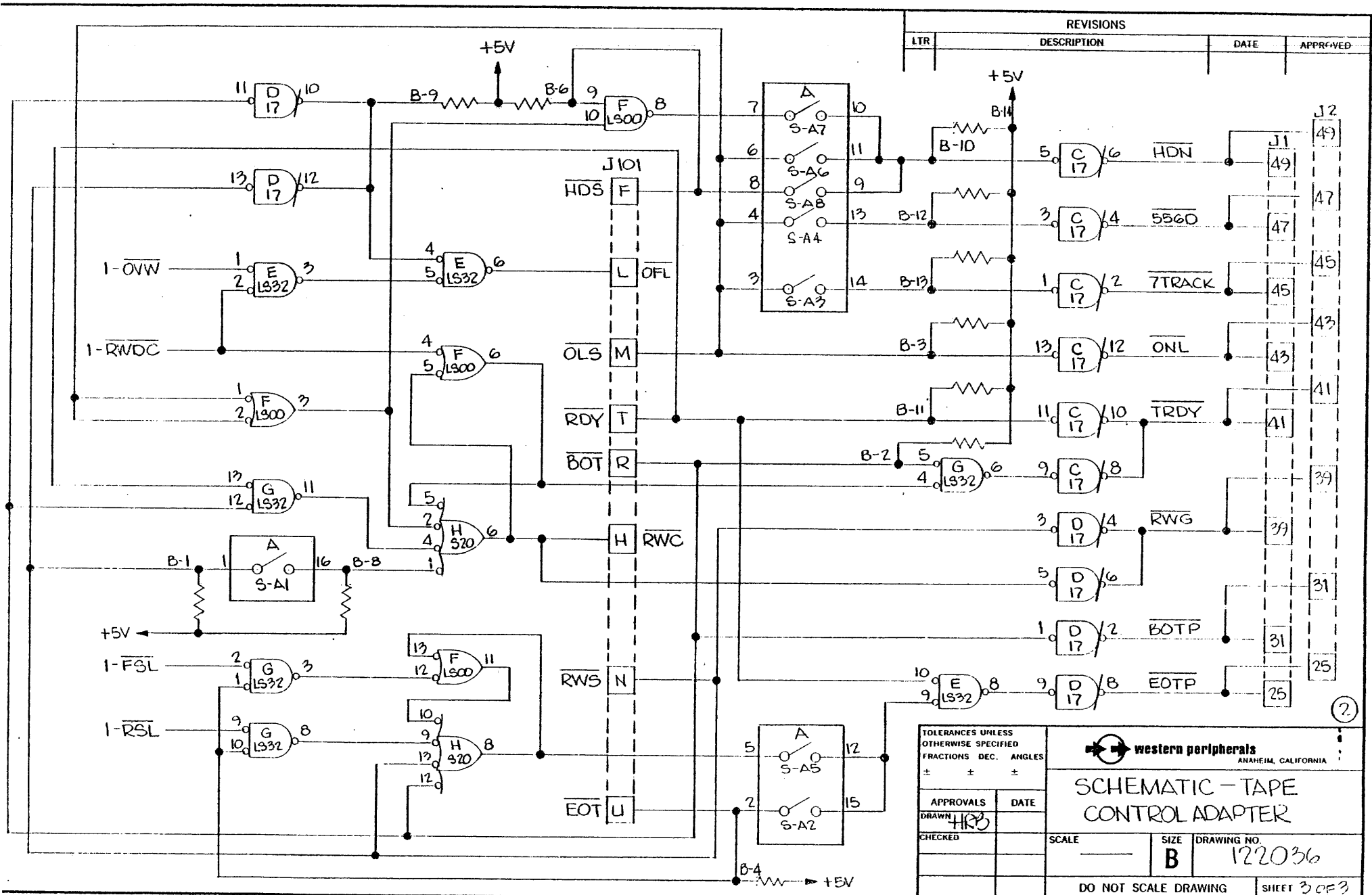

REVISIONS			
LTR	DESCRIPTION	DATE	APPROVED

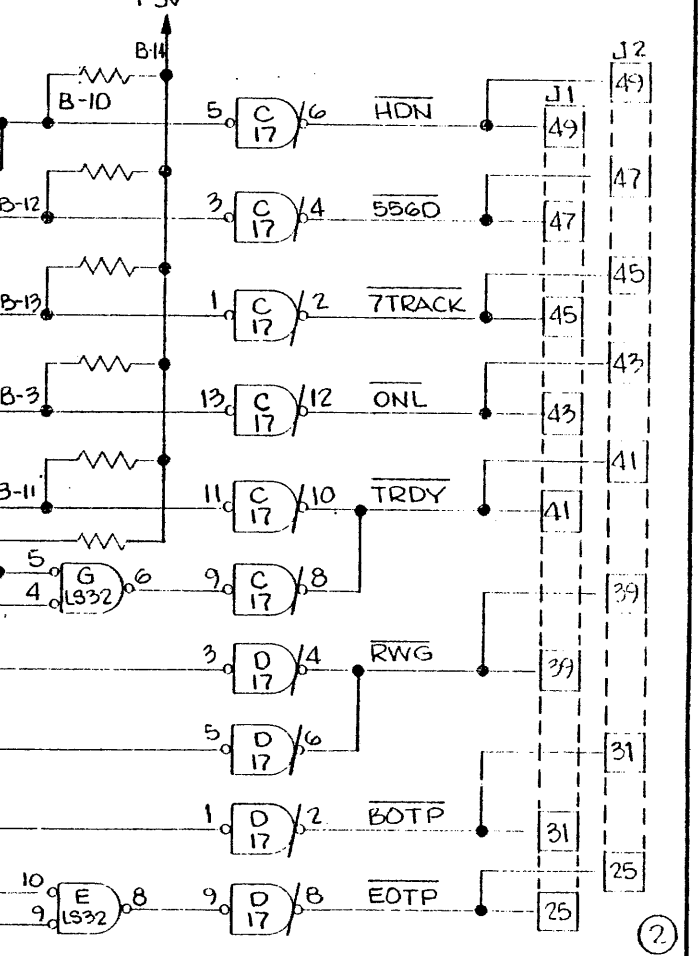

TOLERANCES UNLESS OTHERWISE SPECIFIED	
FRACTIONS DEC. ANGLES	± ± ±
APPROVALS	DATE
DRAWN HRS	
CHECKED	

**western peripherals**  
ANAHEIM, CALIFORNIA

## SCHEMATIC - TAPE CONTROL ADAPTER

SCALE	SIZE	DRAWING NO.
	<b>B</b>	122036

DO NOT SCALE DRAWING      SHEET 3 OF 3

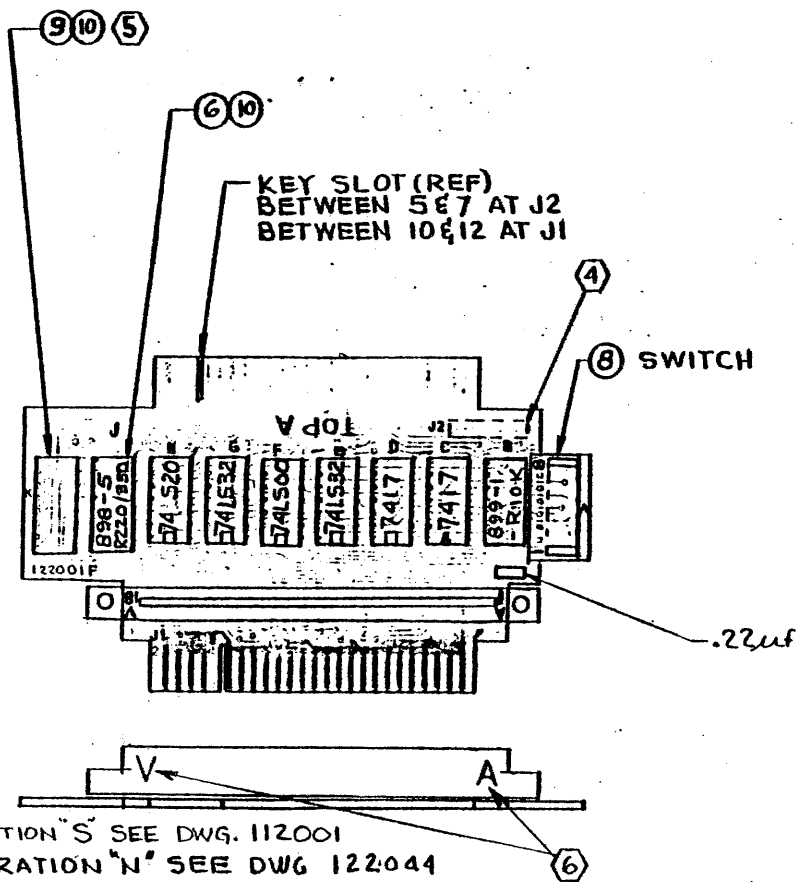

- 9. FOR CONFIGURATION "S" SEE DWG. 112001
- 8. FOR CONFIGURATION "N" SEE DWG 122044
- 7. FOR CONFIGURATION "L" SEE DWG. 130047

- 6. MARK CHARACTERS SHOWN (A & V) ON SIDE OF CONNECTOR USING CONTRASTING INK.
  - 5. FOR OPTIONAL JUMPERING AND/OR JUMPER ARRAYS, REF J.O.A. & SCHEMATIC
  - 4. RUBBER STAMP ASSY NO. WITH LATEST REV LTR AND DASH NO. (IF REQD) APPROX WHERE SHOWN (FAR SIDE)
  - 3.
  - 2. FOR MATERIAL SEE P/L NO. 122037
  - 1. REF SCHEMATIC 122036
- NOTE: UNLESS OTHERWISE SPECIFIED

REVISIONS			
LTR	DESCRIPTION	DATE	APPROVED
A	E.C.O. NO.-0143	1-18-77	
B	E.C.O. NO.-0190	6-3-77	N.D. 11-77
	RECORD CHANGE: ADD CONF. "L" (REV. LTR. CHANGE NOT REQD.)	8-9-77	N.D. 8-9-77
	RECORD CHG: ADD CONF "N" (REV LTR CHG NOT REQD)	9-28-77	N.D. 9-28-77
	RECORD CHG: ADD SH NO. 2 (CLASSY) NO CHG TO BASIC 80 SEE ECO # 0254 (NO REV LTR REQD)	11-10-77	N.D. 11-22-77
	ECO # 299 (NO REV. LTR. CHANGE)	3-8-78	N.D. 3-7-78
C	USE "F" REV. PWB, REF. ECO No. 236A	5-16-78 PAUL CUPPMAN	N.D. 5-16-78
D	DELETED NOTES 3 & 6 PER ECO 411	11-22-79	N.D. 11-22-79
E	CORRECT VALUE SHOWN FOR CAPACITOR PER ECO No. 460	3-6-79 RICHMAN	N.D. 3-6-79
F	ADDED NOTE (C) PER ECO # 504	6-20-77	N.D. 6-20-77

G IC "H" S/B 74520 ECO 806

**BASIC ASSY SHOWN**  
FOR -1 ASSY SEE SH NO. 2

TOLERANCES UNLESS OTHERWISE SPECIFIED FRACTIONS DEC. ANGLES		western peripherals ANAHEIM, CALIFORNIA	
±	±	±	±
APPROVALS	DATE	ASSEMBLY- ADAPTER TAPE CONTROL CONNECTOR	
DRAWN CORLUM	11-8-76	SCALE FULL	SIZE B
CHECKED 7.D.	12-16-76	DRAWING NO. 122037	
DO NOT SCALE DRAWING			SHEET 1 OF 2

0	3	YEL	(A)	122037-1
1	6	RED	(B)	
2	9	GRN	(D)	
3	2	ORG	(C)	
COM	1	BRN	(L)	

REVISIONS			
LTR	DESCRIPTION	DATE	APPROVED

120037-1 WIRING DIAGRAM

ITEM NO.14  
(9 PIN MOLEX PLUG, REF)

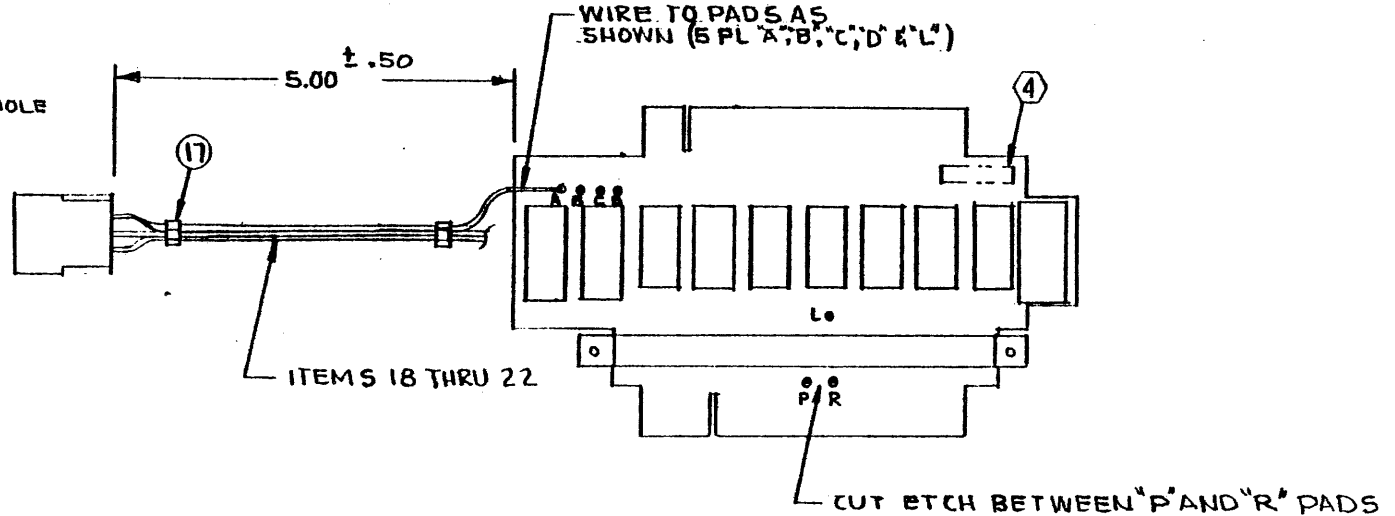
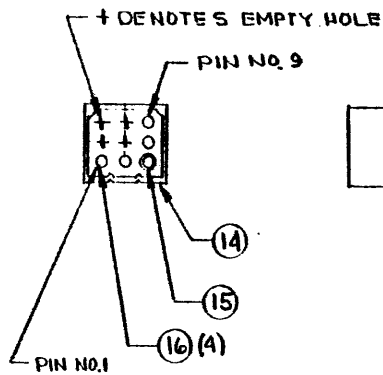

NOTE:

THE -1 ASSY IS USED ON PERTEC T9000 SERIES WITH OPTIONAL UNIT SELECT THUMBWHEEL SWITCH TERMINATED IN MOLEX CONNECTOR. COMPONENT REQUIREMENTS & MARKINGS ARE THE SAME AS FOR BASIC ASSY

-1 ASSY SHOWN  
FOR BASIC ASSY SEE SH NO.1

TOLERANCES UNLESS OTHERWISE SPECIFIED FRACTIONS DEC. ANGLES ± ± ±		 western peripherals ANAHEIM, CALIFORNIA	
APPROVALS		DATE	
DRAWN CORUM		11-19-77	
CHECKED		SCALE	SIZE
		FULL	B
		DRAWING NO. 122037	
DO NOT SCALE DRAWING			SHEET 2 OF 2

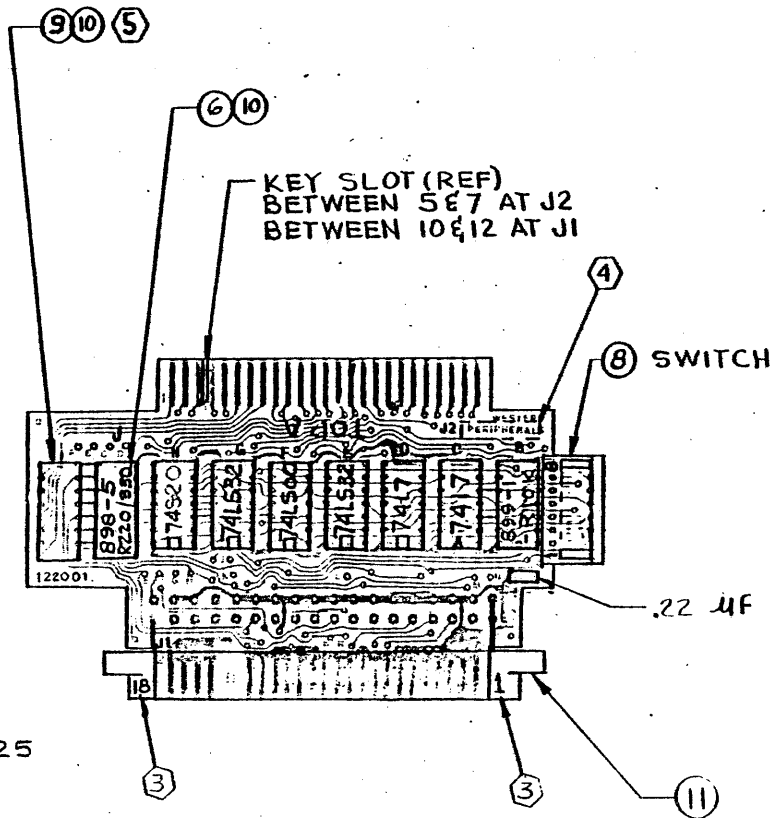

REVISIONS			
LTR	DESCRIPTION	DATE	APPROVED
A	E.C.O. NO. - 0143	1-18-77	
B	E.C.O. NO. - 0190	6-3-77	N.D. 6-11-77
C	E.C.O. NO. - 0197	8-8-77	N.D. 8-9-77
	E.C.O. NO. - 299 (NO REV. LTR. CHG.)	3-8-78	N.D. 3-10-78
	ADDED NOTE 7 PER E.C.O. 257 AND DELETED REQUIREMENT FOR SLEEVING WIRE AT CONNECTOR	3-21-78	N.D. 3-21-78
D	USE "F" REV. PWB, REF. ECO No. 236A	5-16-78	N.D. 5-16-78
E	REVISED NOTE 3 PER E.C.O. 355	10-24-77	
F	DELETED NOTE 6 PER E.C.O. 414	11-24-77	
G	CHANGED I.C. AT LOC H PER ECO 806	12-9-78	
H	INC ECO NO. 852	1-13-81	

FOR CONFIGURATION "S" SEE DWG. 112001  
 FOR CONFIGURATION "N" SEE DWG. 122044

- 1) FOR OPTIONAL JUMPERING AND/OR JUMPER ARRAYS, REF J.O.A. & SCHEMATIC
- 2) RUBBER STAMP ASSY NO. WITH LATEST REV LTR LOCATED APPROX WHERE SHOWN (FAR SIDE)
- 3) RUBBER STAMP CHARACTER SHOWN USING WHITE INK
- 4) FOR MATERIAL SEE P/L NO. 122038
- 5) REF SCHEMATIC 122036
- NOTE: UNLESS OTHERWISE SPECIFIED

REV 27 1981

TOLERANCES UNLESS OTHERWISE SPECIFIED		<b>western peripherals</b> ANAHEIM, CALIFORNIA	
FRACTIONS	DEC.		
±	±	±	<b>ASSEMBLY ADAPTER</b> <b>TAPE CONTROL CONNECTOR</b> <b>90° MOUNTING</b>
APPROVALS	DATE	SCALE	SIZE
DRAWN CORUM	11-8-76	FULL	B
CHECKED N.D.	12-16-76	DRAWING NO.	122038
DO NOT SCALE DRAWING			SHEET 1 OF 1

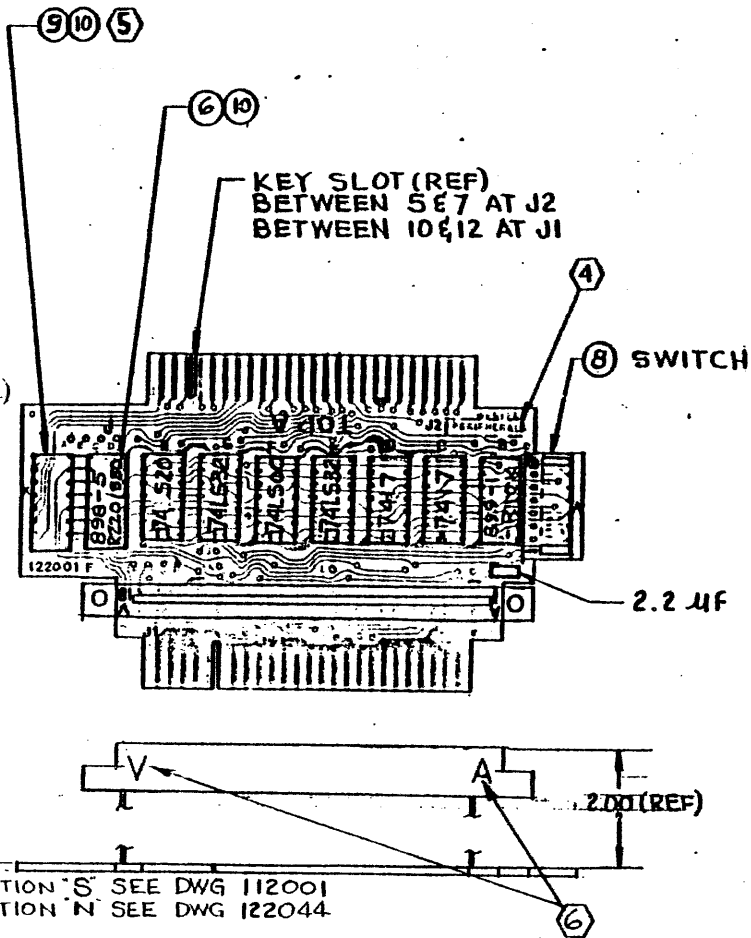

FOR CONFIGURATION 'S' SEE DWG 112001  
 FOR CONFIGURATION 'N' SEE DWG 122044

- MARK CHARACTERS SHOWN (A&V) ON SIDE OF CONNECTOR USING CONTRASTING INK.
- FOR OPTIONAL JUMPERING AND/OR JUMPER ARRAYS, REF J.O.A. & SCHEMATIC
- RUBBER STAMP ASSY NO. WITH LATEST REV LTR LOCATED APPROX WHERE SHOWN (FAR SIDE)

FOR MATERIAL SEE P/L NO. 122039  
 REF SCHEMATIC 122036  
 NOTE: UNLESS OTHERWISE SPECIFIED

REVISIONS			
LTR	DESCRIPTION	DATE	APPROVED
A	E.C.O. NO.-0143	1-18-77	
B	E.C.O. NO.-0190	6-3-77	H.D. 6-11-77
C	E.C.O. NO.-0197	8-8-77	H.D. 8-9-77
	E.C.O. NO.-299 (NO REV. LTR. CHG.)	3-8-78	H.D. 3-21-78
	ADDED NOTE 7. PER E.C.O. 257.	3-21-78	H.D. 3-21-78
D	USE 'F' REV. PWB, REF. ECO No. 236A	5-16-78 (PWA CHANGES)	H.D. 5-16-78
E	DELETED NOTES 3 & 6 PER ECO # 41A	11-21-79	H.D. 11-21-79
F	ADDED NOTE (C) PER ECO # 50A	6-20-79	H.D. 6-20-79
G I.C. "H" S/B 74520		E.C.O. 806	

TOLERANCES UNLESS OTHERWISE SPECIFIED		western peripherals ANAHEIM, CALIFORNIA	
FRACTIONS	DEC.		
±	±	±	ASSEMBLY ADAPTER TAPE CONTROL CONNECTOR 2 INCH STAND OFF
APPROVALS	DATE	SCALE	SIZE
DRAWN CORU JA	11-8-78	FULL	B
CHECKED V.D.	12-8-78	DRAWING NO. 122039	
DO NOT SCALE DRAWING		SHEET 1 OF 1	

REVISIONS			
LTR	DESCRIPTION	DATE	APPROVED
A	REVISED NOTE 1 PER E.C.O.#355	11/22/79	W.H. 2-9-79
B	ADVANCED REV LTR TO AGREE WITH P/L	11/22/79	W.H. 2-9-79
C	REVISED PER E.C.O.#417	11/22/79	W.H. 2-9-79
D	INC ECO NO. 852	3/21/81	(Signature)

KEY SLOT BETWEEN 8 & 10 AT J2  
& BETWEEN 3 & 5 AT J1 (REF)

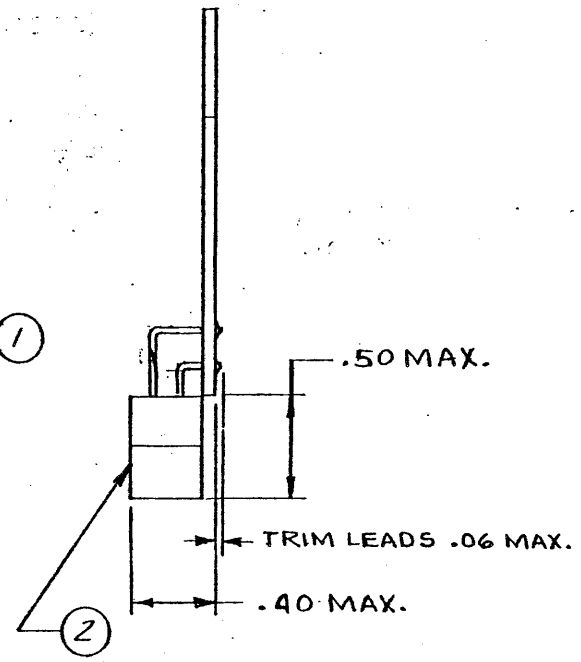
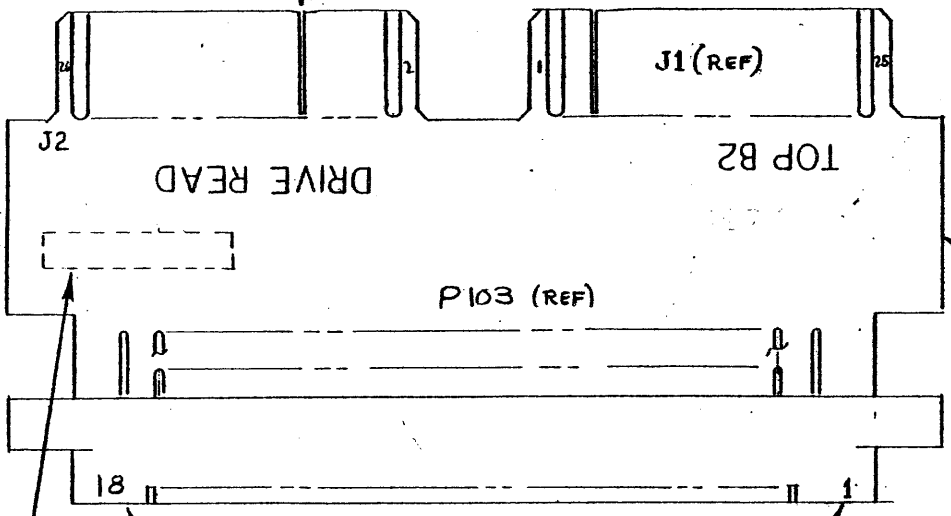

4 (FAR SIDE)

MAR 27 1981

- ④ RUBBER STAMP ASSY. NO. WITH LATEST REV LTR APPROX. WHERE SHOWN.
  - 3. SEE P/L 122043.
  - 2. REF. SCHEMATIC DNG NO. 122022.
  - ① RUBBER STAMP CHARACTERS SHOWN WITH WHITE INK.
- QTE : UNLESS OTHERWISE SPECIFIED.

TOLERANCES UNLESS OTHERWISE SPECIFIED		<b>western peripherals</b> ANAHEIM, CALIFORNIA		
FRACTIONS	DEC. ANGLES			
±	± ±	<b>ASSEMBLY-ADAPTER,          TAPE READ,          REVERSE IMAGE, 90°</b>		
APPROVALS	DATE			
DRAWN W.D.	6/7/77	SCALE 2X	SIZE B	DRAWING NO. 122043
CHECKED W.D.	6-11-77	DO NOT SCALE DRAWING		SHEET 1 OF 1



### CONFIGURATION "N" CONTROL ADAPTER BOARD

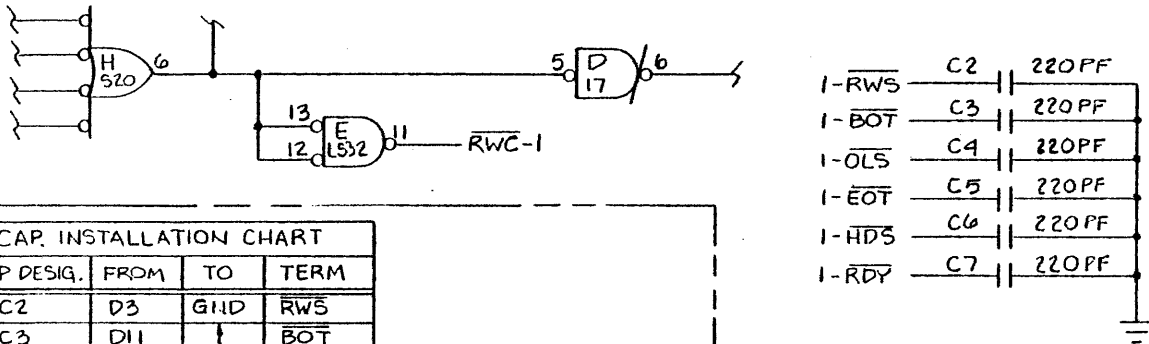

CAP. INSTALLATION CHART			
CAP DESIG.	FROM	TO	TERM
C2	D3	GND	RWS
C3	D11		BOT
C4	F1		OLS
C5	G1		EOT
C6	F9		HDS
C7	G13	GND	RDY

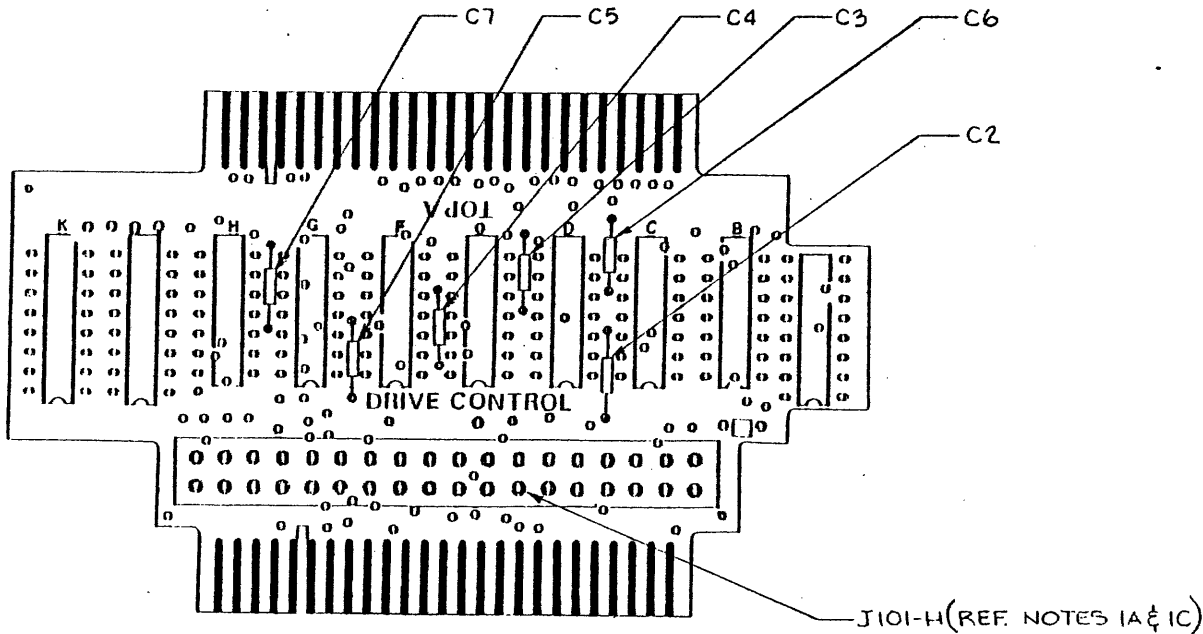

REVISIONS			
LTR	DESCRIPTION	DATE	APPROVED
A	REDRAWN PER E.C.O. 237	10-27-77	
B	REVISE PER E.C.O. 257	3-21-78	
C	REVISE PER E.C.O. 236-A	5-16-78	
D	DELETE REWORK FOR "D" REV PWB PER E.C.O. 781	10-15-80	<i>[Signature]</i>
E	CHANGED I.C. LOC "H" PER E.C.O. ROW	12-2-80	<i>[Signature]</i>

REWORK INSTRUCTIONS: (REF ASSY'S 122037, 122038 & 122039)

- 1) MODIFY CIRCUIT
  - A. CUT ETCH (SOLDER SIDE) AT J101-H
  - B. JUMPER F5 TO E12 & 13 (SOLDER SIDE)
  - C. JUMPER E11 TO J101-H (SOLDER SIDE)
- 2) COMPONENT ADDITION & MARKING
  - A. ADD (6) 220PF CAPACITORS (C2 THRU C7) AT LOCATIONS SHOWN
  - B. IDENTIFY AS "CONF N" AT ASSY NUMBER USING BLACK INK
- 3) THIS MOD PROVIDES ISOLATION & FILTERING FOR ADAPTER ELECTRONICS
- 4) MATERIAL REQUIREMENTS:
  - A. (1 REQ.) BOARD ASSY. AS NOTED IN PROCEDURES ABOVE
  - B. (6 REQ.) 220PF CAPACITORS (WP15000135)
- 5) VERIFY PROPER CAPACITOR INSTALLATION BY PERFORMING CONTINUITY CHECK PER THE CAPACITOR INSTALLATION CHART
- 6) REF. SCHEMATIC 122036
- 7) APPLICABLE TO "F" (OR LATER) REV PWB ONLY. TO RETROFIT OLDER ASSEMBLIES WITH "D" REV PWB, REFER TO "C" REV HISTORY COPY OF THIS DRAWING

DEC 24 1980

TOLERANCES UNLESS OTHERWISE SPECIFIED FRACTIONS DEC ANGLES ± ± ±			western peripherals™ TUSTIN, CALIFORNIA		
APPROVALS		DATE		MODIFICATION DWG- TAPE CONTROL ADAPTER CONFIGURATION "N"	
DRAWN BY AMERSON		10-16-80			
CHECKED S. WILSON		10-16-80			
SCALE				SIZE <b>B</b>	DRAWING NO. 122044
DO NOT SCALE DRAWING				SHEET 1 OF 1	

REVISIONS			
LTR	DESCRIPTION	DATE	APPROVED
X	ENGINEERING RELEASE	2-2-81	ASB

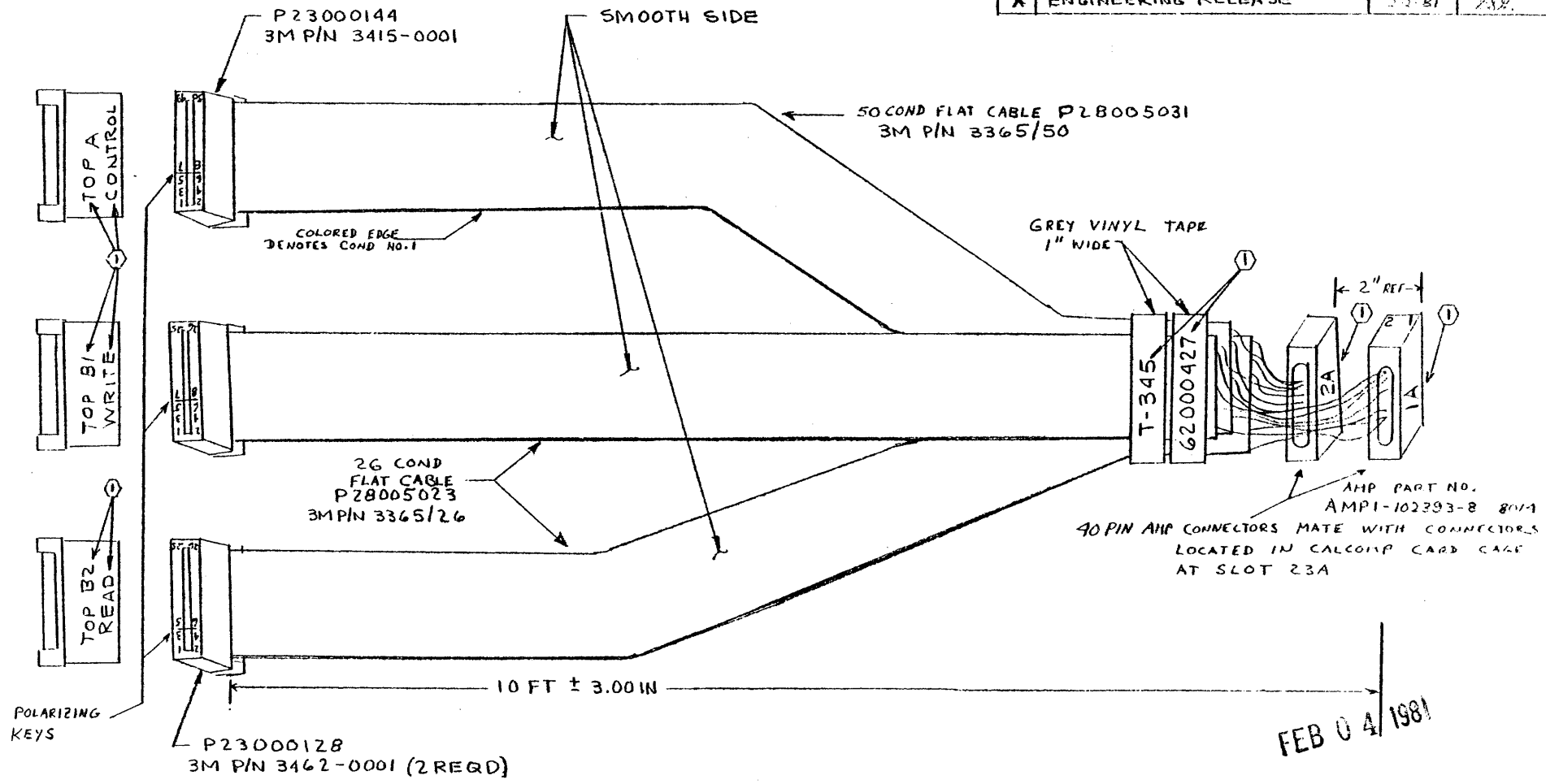

- ① MARK CHARACTERS SHOWN USING CONTRASTING COLOR INK
- 2. ALL EVEN NUMBERED PINS ARE SIGNAL RETURNS
- 3. ALL UNUSED CONDUCTORS MUST BE KEPT ISOLATED FROM EACH OTHER.
- 4. WIRE PER A SIZE SHTS 3, 4, 5 & 6 OF THIS DWG.

FEB 04/1981

TOLERANCES UNLESS OTHERWISE SPECIFIED FRACTIONS DEC ANGLES ± / ± / ± /		 western peripherals™ TUSTIN, CALIFORNIA	
APPROVALS		DATE	
DRAWN CORUM		12-12-80	
CHECKED			
SCALE NO SCALE		SIZE B	DRAWING NO. 62000427
DO NOT SCALE DRAWING			SHEET 1 OF 6

4

3



2

1

INSTALL CONNECTOR 2A

INSTALL CONNECTOR 1A

PIN 04  
REF

PIN 03  
REF

PIN 02  
REF

PIN 01  
REF

PIN 00  
REF

SLOT  
23 A

HINGED EDGE

CAL COMP SWING OUT CARD CAGE  
(SHOWN FOR REF ONLY)

FEB 04 1981



western peripherals™  
TUSTIN, CALIFORNIA

SIZE

CODE IDENT NO

DRAWING NO

B

62000427

SCALE NO SCALE

SHEET 2 OF 6

4

3



2

1

WIRE LIST

By COZUM Date 12-12-80

Sheet 3 of 5

Checked By \_\_\_\_\_

Work Order \_\_\_\_\_

Date \_\_\_\_\_

Drawing 62000427

Rev.

ITEM	FROM	TO	GAGE	COLOR	TYPE ROUT.	LOGIC NAME
	CONTROL "A" CONN	9	2A - 25	50/C FLAT		
	↑	10	↑ - 26	↑		
		11	↓ - 39			
		12	2A - 40			
		13	1A - 39			
		14	↑ - 40			
		15	- 37			
		16	- 38			
		17	↓ - 31			
		18	1A - 32			
		19	2A - 31			
		20	↑ - 32			
		21	- 27			
		22	- 28			
		23	↓ - 35			
		24	2A - 36			
		25	1A - 29			
		26	1A - 30			
		27	2A - 29			
		28	↑ - 30			
	↓	29	↓ - 23	↓		
	CONTROL "A" CONN	30	2A - 24	50/C FLAT		

FEB 0 1981

WIRE LIST

By CORUM Date 12-12-80

Sheet 4 of 5

Checked By \_\_\_\_\_

Work Order \_\_\_\_\_

Date \_\_\_\_\_

Drawing 62000427

Rev. /

ITEM	FROM	TO	GAGE	COLOR	TYPE ROUT.	LOGIC NAME
	CONTROL "A" CONN 3-1	1A - 33	50/C FLAT			
	↑ 32	1A - 34	↑			
	33	2A - 33				
	34	2A - 34				
	39	1A - 25				
	40	↑ - 26 -				
	41	- 23				
	42	- 24				
	↓ 43	↓ - 19	↓			
	CONTROL "A" CONN 44	1A - 20	50/C FLAT			
	WRITE "B1" CONN 1	2A - 21	26/C FLAT			
	↑ 2	↑ - 22	↑			
	3	- 19				
	4	- 20				
	5	↓ - 37				
	6	2A - 38				
	7	1A - 15				
	8	1A - 16				
	11	2A - 15				
	12	↑ - 16				
	↓ 13	↓ - 3	↓			
	WRITE "B1" CONN 14	2A - 4	26/C FLAT			

FEB 0 1981

WIRE LIST

By CORUM Date 12-12-80

Sheet 5 of 6

Checked By \_\_\_\_\_

Work Order \_\_\_\_\_

Date \_\_\_\_\_

Drawing 62000427

Rev. /

ITEM	FROM	TO	GAGE	COLOR	TYPE ROUT.	LOGIC NAME
	WRITE "B1" CONN 15	1A - 11	26/C FLAT			
	↑ 16	↑ -12	↑			
	17	↓ -3				
	18	1A - 4				
	19	2A - 11				
	20	↑ -12				
	21	↓ -7				
	22	2A - 8				
	↓ 23	1A - 7	↓			
	WRITE "B1" CONN 24	1A - 8	26/C FLAT			
	↑					
	READ "B2" CONN 1	2A - 17	26/C FLAT			
	↑ 2	2A - 18	↑			
	3	1A - 13				
	4	1A - 14				
	5	2A - 13				
	6	2A - 14				
	7	1A - 9				
	8	1A - 10				
	9	2A - 9				
	10	2A - 10				
	↓ 11	1A - 5	↓			
	READ "B2" CONN 12	1A - 6	26/C FLAT			

FEB 0 1981



REVISIONS			
LTR	DESCRIPTION	DATE	APPROVED
A	PROD. RLSE	8-29-80	<i>[Signature]</i>
B	REVISE "PURPOSE" PER ECO. 330	1-21-81	<i>[Signature]</i>

PURPOSE:

PROVIDES COMPATABILITY WITH C.D.C. OR OTHER TAPE DRIVES WITH 2.75 INCH SPACING FROM LOAD POINT SENSOR TO READ/WRITE HEAD. (DOES NOT APPLY TO C.D.C 92149)

GENERAL DESCRIPTION:

PROM (PART NO. 120021-A) WHICH USUALLY CONTROLS BOT GAP SPACING MUST BE REPLACED WITH PROM NO. 120028. THE DIFFERENCE IN CONTENT OF ADDRESSES 48 AND 68 IS SHOWN BELOW;

STANDARD (PROM 120021-A)		CONF. "C" (PROM 120028)	
ADD 48	10001111		01110000
ADD 68	11110011		10111011

IMPLEMENTATION:

THE PROM LOCATIONS REQUIRING THE 120028 IN LIEU OF THE 120021-A ARE AS FOLLOWS AND APPLY TO NRZ1 ONLY UNITS AS WELL;

- TC120 (REF. ASSY. 60000411 OR 60000429) LOCATION 2L
- TC130, BD#1 (REF. ASSY. 130017) LOCATION 12C
- TC140 (REF. ASSY. 60000023 OR 60000130) LOCATION 14H
- TC150, BD\*1 (REF. ASSY. 60000080) LOCATION 12C

NOTE:

PROM NUMBERS 120021-A AND 120028 ARE LISTED AS P17009507 AND P17009606 RESPECTIVELY UNDER NEW COMPUTER PART NUMBERING SYSTEM.

JAN 21 1981

TOLERANCES UNLESS OTHERWISE SPECIFIED FRACTIONS DEC. ANGLES ± ± ±		 <b>western peripherals</b> ™ TUSTIN, CALIFORNIA	
APPROVALS		DATE	
DRAWN <i>[Signature]</i> DENNIS ANDERSEN		8-29-80	
CHECKED <i>[Signature]</i>		8-29-80	
SCALE		SIZE	DRAWING NO.
		<b>A</b>	79000402
DO NOT SCALE DRAWING			SHEET 1 OF 1

MODIFICATION DRAWING - TC120/TC130/TC140/TC150 CONFIGURATION "C"



REVISIONS			
LTR	DESCRIPTION	DATE	APPROVED
A	INITIAL RELEASE	9-15-80	<i>[Signature]</i>

PURPOSE: TO PROVIDE START-UP AT 1600 B.P.I.

In order to initialize in the 1600 B.P.I. mode of operation, PROM's U45 and U56 in the upper-left corner of the Control Board must be of the proper type. A jumper must be installed.

1. The Prom Part Numbers can be 754013810 and 754013811 with revision levels of "G" or higher, or they may have part numbers beginning with 154 with any revision level.
2. A jumper must be installed between Pads "BP" and "BR" which are located below the PROMs and directly above U55.
3. After modification, install an adhesive label inside the front panel of the drive near the upper reel motor and Cipher label. The adhesive label should read: "Modified per Western Peripherals Configuration "A", Dwg. 79000410.

SEP 15 1980

TAPE DRIVE MODIFICATION

TOLERANCES UNLESS OTHERWISE SPECIFIED FRACTIONS DEC. ANGLES ± ± ±		 <b>western peripherals</b> ™ TUSTIN, CALIFORNIA	
APPROVALS		DATE	
DRAWN H. DEUTSCH		9-15-80	
CHECKED <i>D. Stralby</i>		9-15-80	
SCALE		SIZE <b>A</b>	DRAWING NO. 79000410
DO NOT SCALE DRAWING			SHEET 1 OF 1

MODIFICATION DRAWING -  
CIPHER 900X, CONFIGURATION "A"

REVISIONS			
LTR	DESCRIPTION	DATE	APPROVED
A	INITIAL RELEASE	12-30-80	<i>[Signature]</i>

PURPOSE: TO ELIMINATE WRITE AND/OR READ ERRORS WHEN TAPE IS AT B.O.T. AND DRIVE IS OFF-LINE.

When Cipher 900X Tape Drives are received from vendor, they have the jumpers set in such a way that if the drive is off-line and at B.O.T., the computer receives a tape unit ready status and Write/Read errors are detected if the CPU attempts any Write/Read operation.

1. To prevent the above from happening, remove jumper BD to BC and install jumper BA to BB located in the vicinity of IC U52 on the Control/Servo PCB of the Cipher 900X type drive.
2. After modification, install an adhesive label inside the front panel of the drive near the upper reel motor and Cipher label. The adhesive label should read: Modified per Western Peripherals Configuration "B", Dwg. 79000642.
3. Reference Cipher Control/Servo Schematic 355012-300.

TOLERANCES UNLESS OTHERWISE SPECIFIED FRACTIONS DEC. ANGLES $\pm$ $\pm$ $\pm$		 <b>western peripherals</b> ™ TUSTIN, CALIFORNIA		
<b>APPROVALS</b> <b>DATE</b>		MODIFICATION DRAWING - CIPHER 900X, CONFIGURATION "B"		
<b>DRAWN</b> <i>[Signature]</i> 12-30-80				
<b>CHECKED</b> <i>[Signature]</i> 12-30-80		<b>SCALE</b>	<b>SIZE</b> <b>A</b>	<b>DRAWING NO.</b> 79000642
		<b>DO NOT SCALE DRAWING</b>		<b>SHEET</b> 1 of 1

## NOTES

### INSTALLATION CHECKLIST - CIPHER 100X

1. Open carton.
2. Turn over and lift off carton.
3. Remove corner pads.
4. Open inner carton.
5. Turn over and lift off carton from drive.
6. Locate manual and mounting hardware.
7. Inspect the drive - Contact the carrier if any concealed shipping damage is discovered.
8. On some cabinets, a mounting frame is required to mount the drive because the door swings against the edge of the cabinet. Mount the extender frame at the appropriate location in the cabinet. Be sure the hinge holes are on the correct side.
9. Refer to the tape drive manual.
10. Mount the tape drive hinges at an appropriate location on the cabinet. Place the longer hinge at the top. Place nylon washers on hinge pins.
11. Place drive on its back and remove screw from shipping frame.
12. Mount drive on hinges and secure with hinge safety block. Secure drive latch.

## NOTES

ADDITIONAL NOTES PRECEEDING APPENDIX