

ROSNER LINC

12D627/200
BREVARD GRAPHICS, INC.

TECHNICAL MANUAL

**OPERATION AND SERVICE INSTRUCTION
WITH PARTS BREAKDOWN**

**AUTOMATIC CODING KEYBOARD
MODEL FK-2**

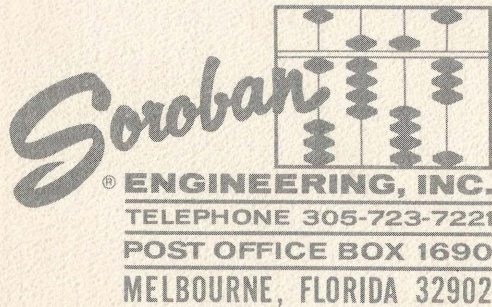

TECHNICAL MANUAL

**OPERATION AND SERVICE INSTRUCTION
WITH PARTS BREAKDOWN**

**AUTOMATIC CODING KEYBOARD
MODEL FK-2**

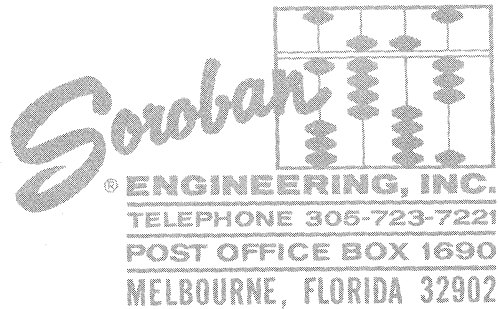

TABLE OF CONTENTS

<u>Section</u>		<u>Page</u>
I	INTRODUCTION AND DESCRIPTION	1-1
	1-1. GENERAL	1-1
	1-2. MANUAL	1-1
	1-3. PURPOSE	1-1
	1-4. KEYBOARD	1-1
	1-5. DESCRIPTION	1-1
	1-6. MECHANISM	1-1
	1-7. PRINCIPLE OF OPERATION	1-1
	1-8. AUTOMATIC CODING KEYBOARD	1-1
	1-9. FUNCTIONAL DIAGRAMS	1-1
II	PREPARATION FOR USE, STORAGE OR SHIPMENT	2-1
	2-1. PREPARATION FOR USE	2-1
	2-2. UNPACKING	2-1
	2-3. INSPECTION	2-1
	2-4. PREPARATION FOR STORAGE OR SHIPMENT	2-1
	2-5. STORAGE	2-1
	2-6. SHIPMENT	2-1
III	FUNCTIONAL OPERATIONS	3-1
	3-1. KEYBOARD	3-1
	3-2. KEYS	3-1
	3-3. INTERLOCK MECHANISM	3-1
	3-4. INTERLOCK SLIDE	3-1
	3-5. SOLENOID	3-1
	3-6. CODE BAR RESET BAIL	3-3
	3-7. CODE BARS	3-3
	3-8. CODE CONTACTS	3-3
	3-9. KEYBOARD COMMON CONTACT	3-3
	3-10. ANTIREPEAT RELAY	3-3
	3-11. SUPPRESSOR	3-3
	3-12. CONTACT CONFIGURATION	3-3
IV	PERIODIC INSPECTION, MAINTENANCE, AND LUBRICATION	4-1
	4-1. INSPECTION	4-1
	4-2. KEYBOARD LUBRICATION	4-1
V	TROUBLE SHOOTING	5-1
	5-1. TROUBLE SHOOTING	5-1
	5-2. TROUBLE SHOOTING CHART	5-1
	5-3. TROUBLE SHOOTING PROCEDURES	5-1
	5-4. ADJUSTING INTERLOCK BALLS	5-2
	5-5. POSITIONING INTERLOCK SLIDE	5-2
	5-6. ADJUSTING SOLENOID SWITCH	5-2
	5-7. REPLACING SOLENOID SWITCH	5-2
	5-8. REPLACING SOLENOID	5-2
	5-9. ADJUSTMENT OF CODE SWITCH OR CONTACTS	5-2
	5-10. REPLACEMENT OF CODE CONTACT	5-3
	5-11. ADJUSTMENT OF THE COMMON CONTACT	5-3
	5-12. REPLACEMENT OF COMMON CONTACT	5-3
	5-13. REPLACING THE RELAY	5-3
VI	ILLUSTRATED PARTS BREAKDOWN	6-1
	6-1. GENERAL	6-1

LIST OF ILLUSTRATIONS

<u>Figure</u>		<u>Page</u>
1-1.	Automatic Keyboard Control Circuit	1-1
1-2.	Typical Automatic Coding Keyboards	1-2
3-1.	Keyboard Mechanical Components	3-2
3-2.	Typical Coding Chart	3-4
4-1.	Lubrication Chart	4-1
5-1.	Trouble Shooting Chart	5-1
6-1.	Automatic Coding Keyboard, Exploded View	6-3

SECTION I

INTRODUCTION AND DESCRIPTION

1-1. GENERAL

1-2. MANUAL. This manual contains operation and service instructions with parts breakdown for the Automatic Coding Keyboard, Model FK-2 series.

1-3. PURPOSE

1-4. KEYBOARD. The Automatic Coding Keyboard is a manually operated keyboard which generates an electrical parallel coded output which may be arbitrarily chosen to represent the alphabetic, Arabic numeral, and other keyboard symbols.

1-5. DESCRIPTION

1-6. MECHANISM. The keyboard is both mechanically and electrically interlocked. Only one key may be depressed at a given time. A mechanical matrix is used to produce digit coding with a maximum of eight parallel

bits per code plus common. Keyboards are available with almost any button arrangement with a maximum of 64 keys. The working mechanism consists primarily of top and bottom key guide frames, keys, code bars, interlock mechanism, an interlock slide, a relay, a rotary solenoid, and an end plate, on which are mounted up to eight coding switches or contacts and a solenoid switch. For detailed description see Section III.

1-7. PRINCIPLE OF OPERATION

1-8. AUTOMATIC CODING KEYBOARD. The Automatic Coding Keyboard is entirely automatic in operation. The operator sequentially depresses the keys corresponding to the information to be coded, and the keyboard automatically generates the required electrical coded output.

1-9. FUNCTIONAL DIAGRAMS. A typical keyboard control circuit and mechanical components are shown in figures 1-1 and 3-1.

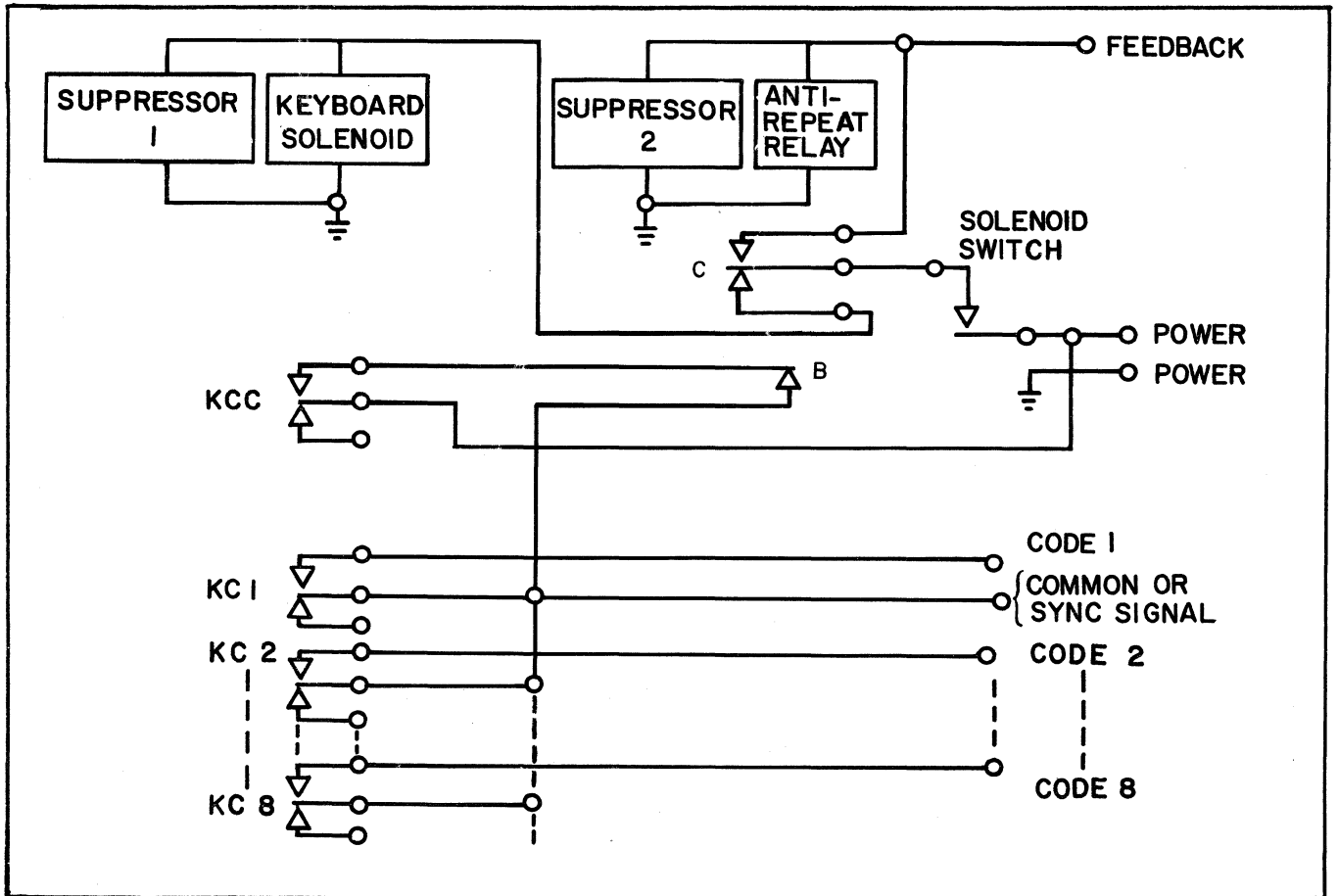
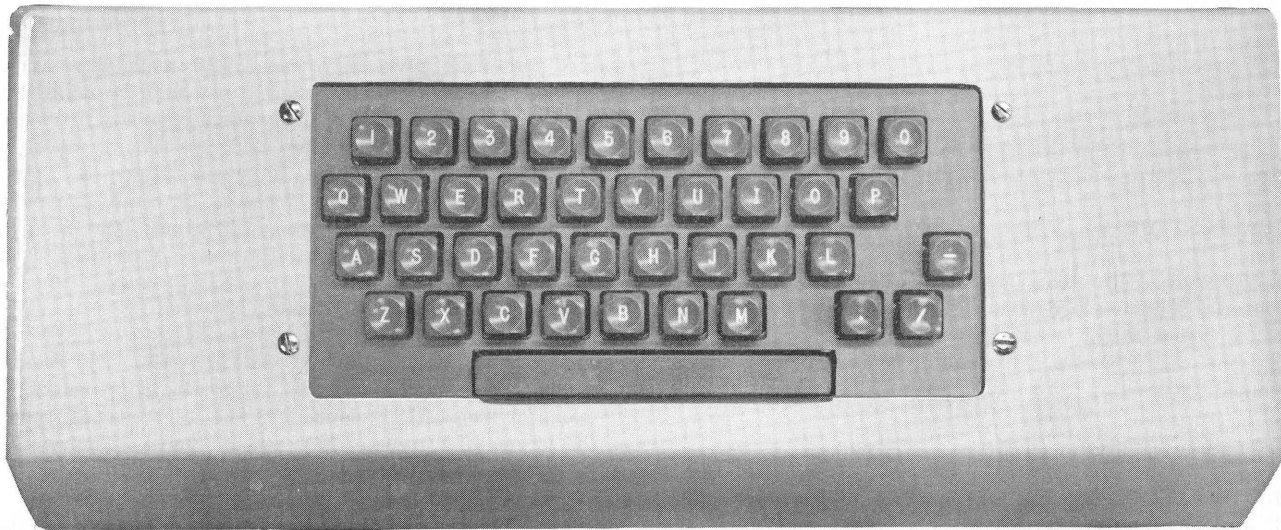

Figure 1-1. Automatic Keyboard Control Circuit



FK-2 KEYBOARD - ALPHANUMERIC



FK-2 KEYBOARD - NUMERIC

Figure 1-2. Typical Automatic Coding Keyboards

SECTION II

PREPARATION FOR USE, STORAGE OR SHIPMENT

2-1. PREPARATION FOR USE

2-2. UNPACKING. Check receiving carton before opening to insure no visible exterior damage is evident. Normal care should be used in unpacking to avoid scratching the surface of the Keyboard.

2-3. INSPECTION. The Keyboard as shipped has been thoroughly tested and released by our Quality Control Department. As shipped, it is packaged to avoid damage from any normal handling. Before applying power to the unit, check that all keybuttons can be depressed easily one at a time, and that they return freely. Check also that only one button can be depressed at a time (with the exception in some requirements of special control buttons which do not enter the interlocking mechanism as called for in the customer specification). No preliminary lubrication is necessary.

2-4. PREPARATION FOR STORAGE OR SHIPMENT

2-5. STORAGE. If the unit is to be stored or left unused for any extended periods of time, it should be protected from dirt and grime with a suitable dust cover. Storage can be at any temperature from -40°F to $+160^{\circ}\text{F}$. If the unit is left stored for a protracted period of time or at extreme temperatures, it should be relubricated in accordance with Section IV.

2-6. SHIPMENT. In reshipping the unit where it is mounted in part of the customer's mechanism, caution should be used to avoid any tendency to twist the frame of the Keyboard which might produce binding of the keys or misaligning of the code bars. In cases where the unit has to be shipped or handled outside of its protective case, care must be exerted that no objects come in contact with the electrical contacts which might distort them so as to change the timing of the contacts. Care must also be used to avoid any dirt or packing material getting into the Keyboard.

SECTION III

FUNCTIONAL OPERATIONS

3-1. KEYBOARD. Functions of the keyboard are as follows:

a. Provides high-speed mechanical generation of the required electrical code symbols.

b. Incorporates a mechanism which prevents depression of more than one key at a time.

c. Incorporates a mechanism which prevents accidental repetition of a code character.

d. Incorporates a mechanism which prevents release of the key until the coding of that character is complete.

3-2. KEYS. The generation of each coded signal is initiated by depressing one of the keys or the space bar. The keys move in two nylon guides, and each key includes a horizontal portion wide enough to engage all of the code bars described in paragraph 3-7. The keys and space bar are suspended on springs which hold them at the top of their travel except when manually depressed. Figure 3-1 shows two key forms, (1) and (2). Key form (1) is used on Row 1 and Row 4 on the keyboard, and key form (2) is used on the intervening rows of keys.

3-3. INTERLOCK MECHANISM. The interlock mechanism (3, figure 3-1) is provided to prevent depression of more than one key at a time, either by depressing two keys at once or by depressing a second key while the

first key is still in the coding cycle. A slotted retainer is mounted lengthwise in the center of the top key guide frame and is filled with steel balls. By means of an adjusting screw on the end plate, enough clearance is allowed among the steel balls to tolerate the passage of a single key. A rectangular opening in each of the keys permits free movement of the steel balls through all of the keys until one is depressed. As a key is depressed, the steel balls are forced into close contact, making it impossible to depress a second key.

3-4. INTERLOCK SLIDE. Running lengthwise through the mechanism and just below the interlock mechanism is the interlock slide (4, figure 3-1). In the upper edge of the slide is a series of slots cut at an angle to the top edge of the slide. When any of the keys are depressed, a projection on the under side of the key enters one of these slots. Because of the angle of the slots, the slide is forced toward the contact plate. As this happens, the upper edge of the slot moves into an opening in the key and locks the key into the depressed position until the interlock slide can be returned to normal position. As the slide moves toward the end plate, it also causes the solenoid switch (10, figure 3-1) to close. (See schematic, figure 1-1.)

3-5. SOLENOID. The rotary solenoid (5, figure 3-1) has the same basic in-and-out action as other solenoids. However, because of the inclined runways stamped into the end of the solenoid body and in the moving end plate with steel balls in these runways, the end plate takes a rotary motion.

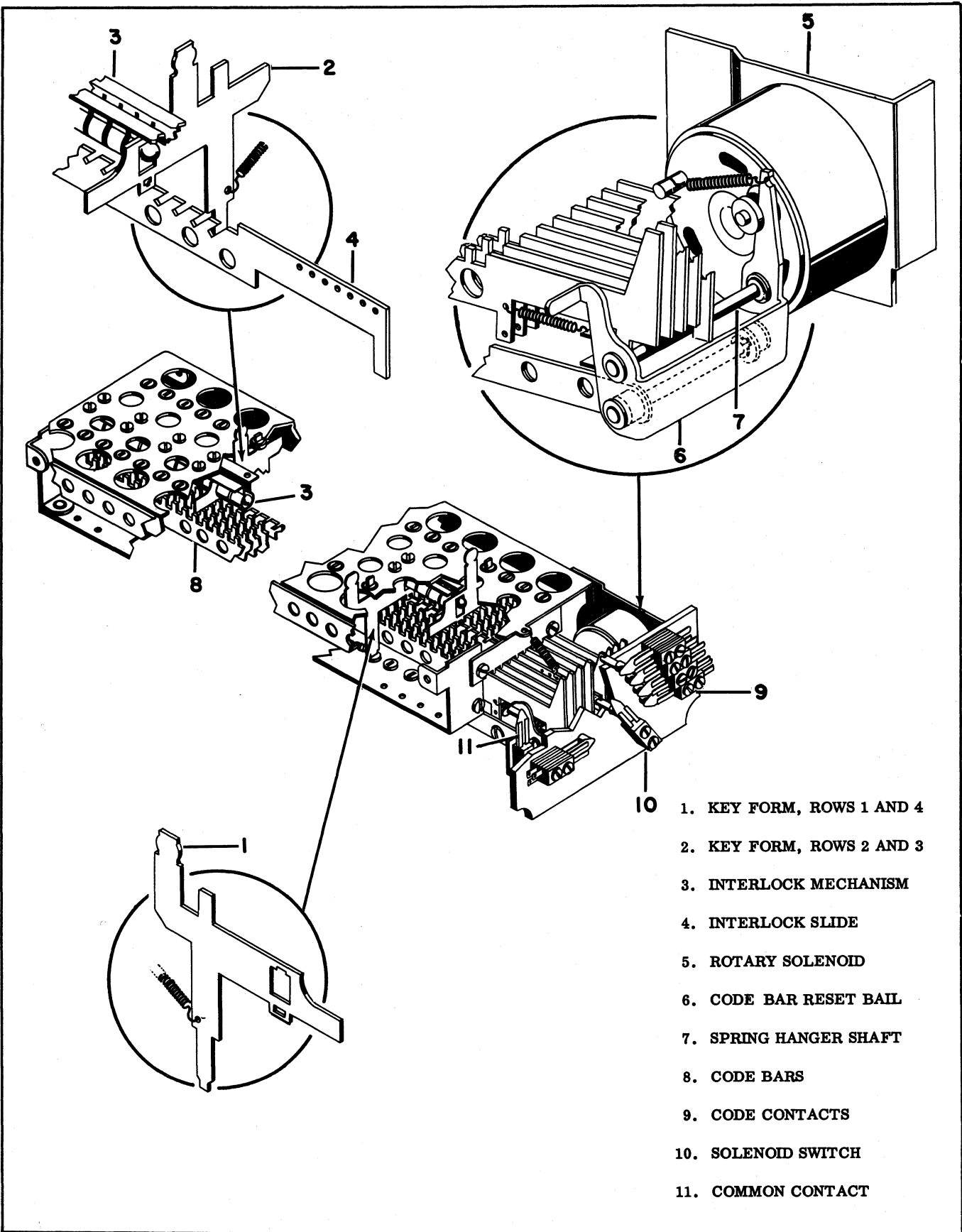

- 1. KEY FORM, ROWS 1 AND 4
- 2. KEY FORM, ROWS 2 AND 3
- 3. INTERLOCK MECHANISM
- 4. INTERLOCK SLIDE
- 5. ROTARY SOLENOID
- 6. CODE BAR RESET BAIL
- 7. SPRING HANGER SHAFT
- 8. CODE BARS
- 9. CODE CONTACTS
- 10. SOLENOID SWITCH
- 11. COMMON CONTACT

Figure 3-1. Keyboard Mechanical Components

3-6. **CODE BAR RESET BAIL.** When the solenoid is energized, the top of the code bar reset bail (6, figure 3-1) is moved toward the contact plate of the coding keyboard. The bottom of the bail is held by the reset bail shaft, which acts as a pivot. Running horizontally through the reset bail about halfway from the pivot to the top is the spring hanger shaft (7, figure 3-1). This shaft anchors the code bar spring hanger to the reset bail. From the code bar spring hanger, springs extend to each of the code bars. Also, as the reset bail moves toward the end plate, the spring hanger shaft moves up behind a tab on the end of the interlock slide and locks it, thereby locking the key into its depressed position until power is removed from the rotary solenoid.

3-7. **CODE BARS.** There are up to eight code bars in the Automatic Coding Keyboard, four on each side of the interlock slide and parallel to it. Like the interlock slide, the code bars are slotted at each key position, but in this case the slots are vertical instead of angled (8, figure 3-1). When any key is depressed, the horizontal part of the key drops into these slots and inhibits all of the code bars not involved in generating the code for that particular key. The code bars which are involved have the inhibiting tooth for that key removed so that the code bar is free to slide under the key. When the solenoid is activated, the motion of the code bar reset bail moves the code bar spring hanger toward the end plate. This action puts tension on the code bar springs, which attempt to pull each of the code bars toward the end plate. Those which have been locked by the depressing of the key cannot move. Those which have had a tooth removed, however, are drawn toward the end plate by the springs and activate the corresponding code contacts on the contact plate. The motion of the code bar reset bail also closes the common contact, thereby providing a current source to the code contacts, which are thus enabled to produce the necessary coded output.

3-8. **CODE CONTACTS.** Code contacts (9, figure 3-1) can be either normally open or transfer contacts. When a code bar moves toward the end plate, it forces the corresponding pusher to move against the contact pole causing the switch to transfer.

3-9. **KEYBOARD COMMON CONTACT.** (11, figure 3-1). This contact is operated by the rotary solenoid through the code bar reset bail. It is adjusted to close late in the

energize portion of the cycle of the solenoid so that all unblocked code contacts will transfer before common contact.

3-10. **ANTIREPEAT RELAY.** When the interlock slide moves laterally thereby closing the solenoid switch, the solenoid is energized causing the unblocked code bars to come forward and causing the keyboard common contact (KCC) to transfer. This puts power through a normally closed contact on the antirepeat relay to the common line or sync signal output. If the operator takes his finger off the key, the keyboard remains locked up because the energized solenoid will not release the interlock slide to allow the solenoid switch to open. A feedback signal must be presented to energize the antirepeat relay thereby interrupting power to the keyboard solenoid. Note that if the operator still has his finger on the key when the antirepeat relay is energized by the feedback source, he can still get only one output. This is because the antirepeat relay will also get power through the transfer action of the "C" contact, and in energizing the antirepeat relay, we are interrupting power to the sync line and thereby all the code lines through the "B" contact.

If a fixed width pulse output is required, the output of the common line can be jumpered to the "feedback" terminal (figure 1-1) so that when the operator presses a key, the solenoid is energized bringing power through on the common line to the antirepeat relay. This will then become energized to complete the cycle. This will give a pulse output whose length is determined by the pickup time of the antirepeat relay. Variations on these control circuits are frequently supplied depending upon the particular requirement of the keyboard. Under conditions where a longer pulse output is required, a second relay with a variable delay can be incorporated to give pulse outputs up to 30 milliseconds.

3-11. **SUPPRESSOR.** Both the relay and solenoid are suppressed to minimize arcing. These suppressions are dependent upon the customer's application and can consist of a resistor and condenser in series, a diode, or a diode with resistor and/or condenser. If a diode is used, care must be used to apply DC power with the proper polarization to the keyboard solenoid and relay circuits.

3-12. **CONTACT CONFIGURATION.** The format of the code generated by a typical K2 Coding Keyboard is shown in figure 3-2.

Section III

FK-2 SPECIFICATIONS

- Coding:** Up to 8 bits plus common; mechanically produced; (up to 16 bits on special order).
- Speed:** Limited only by driven apparatus, or operator and the delays in the driven mechanism.
- Key Pressure:** Approximately 6 oz. (can be varied to order).
- Code Contacts KC:** Bifurcated leafs, form A preferred, palladium or Paliney 7 contacts, 30 grams minimum force.
- Common Contacts KCC:** Bifurcated leafs using palladium contacts, Form A or C.
- Coding Pulse Duration:** Fixed 10 to 30 ms, or under control of driven apparatus.
- Contact Bounce:** Maximum of 3 ms, completed within 10 ms of initial contact closure.
- Keyboard Size:** FK-2S (21 keys or less)
FK-2M (22 - 44 keys)
FK-2L (45 - 64 keys)
- Total Output Load:** Unsuppressed, not more than 2 amps with non-inductive load.
- Drive Solenoid:** Operable from a specified voltage between 6 VDC and 100 VDC, unfiltered 15 watts (25 watts in some of the FK-2L Keyboards).
- Available Configuration:** Up to 64 keys, including space bar.
- Key Button Colors:** Grey, dark red, green, black, yellow, brown, dark blue, orange, ivory.
- Key Bar Colors:** Grey, black.
- Finish:** Soroban light grey enamel or special finish on request.
- Weight:** Approximately 4-10 lbs., depending on size.

CODING CHART								
KEY	CODE							
FUNCTION	8	7	6	5	4	3	2	1
RETURN	X							
SHIFT ↓ (L.C.)		X	X	X	X	X	X	X
SPACE		X	X	X	X	X	X	X
V		X	X	X	X	X	X	X
K		X	X	X	X	X	X	X
I		X	X	X	X	X	X	X
O (ZERO)		X	X	X	X	X	X	X
U		X	X	X	X	X	X	X
J		X	X	X	X	X	X	X
STOP		X	X	X	X	X	X	X
9		X	X	X	X	X	X	X
T		X	X	X	X	X	X	X
I		X	X	X	X	X	X	X
.		X	X	X	X	X	X	X
8		X	X	X	X	X	X	X
S		X	X	X	X	X	X	X
H		X	X	X	X	X	X	X
5PL CODE		X	X	X	X	X	X	X
7		X	X	X	X	X	X	X
R		X	X	X	X	X	X	X
G		X	X	X	X	X	X	X
.		X	X	X	X	X	X	X
6		X	X	X	X	X	X	X
Q		X	X	X	X	X	X	X
F		X	X	X	X	X	X	X
-		X	X	X	X	X	X	X
5		X	X	X	X	X	X	X
P		X	X	X	X	X	X	X
E		X	X	X	X	X	X	X
Z		X	X	X	X	X	X	X
4		X	X	X	X	X	X	X
O		X	X	X	X	X	X	X
D		X	X	X	X	X	X	X
Y		X	X	X	X	X	X	X
3		X	X	X	X	X	X	X
N		X	X	X	X	X	X	X
C		X	X	X	X	X	X	X
X		X	X	X	X	X	X	X
2		X	X	X	X	X	X	X
M		X	X	X	X	X	X	X
B		X	X	X	X	X	X	X
W		X	X	X	X	X	X	X
I		X	X	X	X	X	X	X
L		X	X	X	X	X	X	X
A		X	X	X	X	X	X	X
SHIFT ↑ (U.C.)		X	X	X	X	X	X	X
TAB		X	X	X	X	X	X	X

X = TEETH REMOVED FROM CODE BARS.
CODE CONTACTS WHICH CLOSE

Figure 3-2. Typical Coding Chart

SECTION IV

PERIODIC INSPECTION, MAINTENANCE, AND LUBRICATION

4-1. INSPECTION. Inspection is necessary only upon installation. The keys shall be depressed one at a time and checked for freedom of movement. The keyboard should be disassembled only when necessary because of malfunction. In case of malfunction, refer to Section V. No maintenance is required other than routine lubrication.

4-2. KEYBOARD LUBRICATION. The keyboard is lubricated at the factory during final test and adjustment. Only when removed for repair or adjustment is relubrication necessary or once a year, whichever occurs first. Refer to figure 4-1 for detailed lubrication information.

ITEM	LUBRICANT	METHOD OF APPLICATION	INTERVAL
Interlocking Balls (24, figure 6-1)	Light Oil, MIL-L-6085	One drop from can	After repair or adjustment
Solenoid Spring Pivots (19, figure 6-1)	Light Oil, MIL-L-6085	One drop from can	After repair or adjustment
Interlock Slide (35, figure 6-1)	Light Oil, MIL-L-6085	One drop from can	After repair or adjustment
Code Bar Retainer at opposite end from contact plate (10, figure 6-1)	Light Oil, MIL-L-6085	One drop from can	After repair or adjustment
Code Bar & Interlock Guide Sur- faces (12, 38, 39 & 41, figure 6-1)	Light Oil, MIL-L-6085	One drop from can	After repair or adjustment
Rotary Solenoid (Plates and Balls) (18, figure 6-1)	Light Oil, MIL-L-6085	One drop from can	After repair or adjustment
Spring Hanger Shaft (44, figure 6-1)	Light Grease, MIL-G-3278	Hand wipe lightly	After repair or adjustment

Figure 4-1. Lubrication Chart

SECTION V

TROUBLE SHOOTING

5-1. TROUBLE SHOOTING

5-2. TROUBLE SHOOTING CHART. Figure 5-1 contains a list of the most likely troubles that may be encountered, their probable causes and suggested remedies. In case of malfunction of the keyboard, refer to the Trouble Shooting Chart and Trouble Shooting Procedures.

5-3. TROUBLE SHOOTING PROCEDURES. Remove the cover from the keyboard for access.

WARNING

Make corrections and adjustments with the power off.

TROUBLE	PROBABLE CAUSE	REMEDY
Key will not depress.	<ul style="list-style-type: none"> a. Tight contact of steel balls in interlock mechanism. b. Interlock slide (35; figure 6-1) binding. c. Interlock slide not properly positioned. d. Code bars (33, figure 6-1) inhibiting the key. 	<p>Adjust as necessary. Refer to Paragraph 5-4.</p> <p>Lubricate. Refer to figure 4-1.</p> <p>Adjust as necessary. Refer to Paragraph 5-5.</p> <p>Readjust solenoid. Refer to Paragraph 5-8d.</p>
Keys depress but nothing happens.	<ul style="list-style-type: none"> a. No power reaching keyboard. b. Power reaching keyboard but not reaching solenoid (18, figure 6-1). c. Power reaching solenoid but solenoid defective. 	<p>Check for power to plug-in connector. Check seating of connector (64, figure 6-1).</p> <p>Close solenoid switch (28, figure 6-1) manually. If solenoid actuates, adjust or replace switch. Refer to Paragraph 5-6.</p> <p>Replace and adjust solenoid. Refer to Paragraph 5-8.</p>
Key depresses but does not return.	<ul style="list-style-type: none"> a. Broken reset spring. 	<p>Replace spring (20, figure 6-1).</p>
Keyboard operates but does not produce the correct code.	<ul style="list-style-type: none"> a. One or more code bars not operating. b. Code contact defective. c. Common contact not closing. 	<p>Check code bars for free movement. Lubricate if binding. Refer to figure 4-1. Position code bars by adjusting solenoid. Check for broken springs between code bars and bail (34, figure 6-1).</p> <p>Adjust or replace code contacts. Refer to Paragraph 5-9.</p> <p>Adjust or replace common contact. Refer to Paragraph 5-11.</p>
Keyboard locks and does not release.	<ul style="list-style-type: none"> a. Relay (37, figure 6-1) not receiving feedback. b. Relay receiving feedback but not operating. 	<p>Check electric circuits for continuity (figure 1-1).</p> <p>Replace relay. Refer to Paragraph 5-13.</p>

Figure 5-1. Trouble Shooting Chart

5-4. ADJUSTING INTERLOCK BALLS. The interlock ball race is adjusted by means of an adjusting screw (66, figure 6-1) as follows:

NOTE

No adjustment should be necessary unless the adjustment has been tampered with or the mechanism has been disassembled.

a. Advance the adjusting screw until no key can be depressed.

b. Back off the adjusting screw just far enough to allow a single key to be depressed.

c. If, with one key depressed, a second key can also be depressed, the adjustment is incorrect and should be made again. Correct adjustment will not permit a second key to be depressed when one is already depressed.

5-5. POSITIONING INTERLOCK SLIDE. Positioning of the interlock slide is accomplished by the adjustment stop (9, figure 6-1). No adjustment is necessary unless the mechanism has been disassembled. In this case, the following procedure must be observed.

a. Depress any single key. If the interlock balls have been properly positioned and the key still cannot be depressed, the interlock slide is in improper position. While checking the keyboard operation visually, move the adjustment until the projection on the bottom of the key can enter the corresponding slot in the interlock slide, thereby allowing the key to be depressed.

b. While holding the key down, move the rotary solenoid manually to its advanced position and release the key. If the interlock slide is now positioned properly, it will lock the key down.

c. If the key is still not locked in the depressed position, the interlock slide must be moved further toward the contact plate until the upper side of the angled slot in the interlock slide will hold the key in depressed position when the solenoid is advanced manually.

d. Release the solenoid and let the interlock slide return to its starting position. If it does not release the key in this position, change the adjustment to allow the slide to move away from the contact plate just enough to release the key.

5-6. ADJUSTING SOLENOID SWITCH. Adjust solenoid switch as follows:

a. Using a standard contact adjusting tool, adjust contacts of the solenoid switch (28, figure 6-1) so that firm contact is made as the interlock slide moves toward its closest position to the contact plate. Unless firm contact is made, the solenoid will not be energized and no further action will take place in the keyboard.

b. If adjustment does not result in proper contact, replace the switch.

5-7. REPLACING SOLENOID SWITCH. Replace switch as follows:

a. Remove the two mounting screws, unsolder the two leads from the switch, and remove switch.

b. Mount new switch by means of the two mounting screws.

c. Resolder the two leads.

d. Depress one of the keys and observe the new contacts carefully for proper closing, adjusting as necessary.

5-8. REPLACING SOLENOID. If diagnosis indicates defective solenoid, replace as follows:

a. Remove the solenoid support (16, figure 6-1) by disconnecting the leads from the miniature jacks (17, figure 6-1), and remove the four screws mounting the solenoid support to the keyboard.

b. Remove defective solenoid from the solenoid support by removing the two nuts and two washers and pull the two electrical leads from the solenoid out of the miniature jacks (17, figure 6-1).

c. Install the new solenoid in proper position and replace the two washers and two screws but do not tighten them. Insert the two electrical leads from the solenoid in the two miniature jacks from which the other leads were removed. Then mount solenoid support to keyboard and connect the wires.

d. To position the solenoid, depress the key closest to it, checking the clearance between the code bars and key visually. Move the solenoid back and forth until the clearance between the code bars and the key is approximately 0.005 to 0.015 inch. This clearance need not be exact but must be just sufficient to allow the keys to depress without interference with the code bars.

e. Hold solenoid in proper position and tighten mounting nuts securely.

5-9. ADJUSTMENT OF CODE SWITCH OR CONTACTS. Adjust as follows:

a. Depress the keys one at a time and carefully observe the movement of the code bars and code contacts. For each key pressed, certain of the code bars will move and attempt to break contact in the code contacts. The contacts for each inhibited code bar must remain closed, and the contacts for each moving code bar must open. If any of the contacts fail to open when moved by a code bar or to close when the code bar returns to position, the contacts must be adjusted.

b. Adjust each defective contact with a standard contact adjusting tool.

c. Again observe the operation of the contact when keys are depressed.

d. If proper operation still is not obtained, replace the contact.

5-10. REPLACEMENT OF CODE CONTACT. Replace as follows:

a. To replace any contact, remove the two mounting screws and the two soldered leads, mount a new contact in this position, and replace the screws and the leads.

b. After installing the new contact, check the action as each of the keys is depressed and adjust the contact until correct operation is secured.

5-11. ADJUSTMENT OF THE COMMON CONTACT. The common contact must operate after the coding contacts have operated and must return to starting position before the code contacts return to starting position. Its contact must be extremely brief. Adjustment of the common contact is made by tilting the entire common contact and its mounting bracket. The bracket is held by two screws, and the bracket tilts on the screw closest to the contact plate with the farther screw as the locking adjustment.

NOTE

An oscilloscope test setup is expedient for the following observations and adjustments.

a. Depress one of the keys and operate the solenoid manually. Observe carefully the closing time of the coding contacts and of the common contact.

b. Adjust by tilting the common contact to a point where it will open about two milliseconds after the others. This adjustment will be accomplished by adjusting so that firm closing of the common contact is made almost at the end of the forward travel of the solenoid.

5-12. REPLACEMENT OF COMMON CONTACT. Replace as follows:

a. Replace contact by unsoldering leads and remove two mounting screws.

b. Install new contact by soldering leads to contact and mounting contact on bracket and secure with two mounting screws.

c. When proper adjustment is obtained, lock the bracket into proper position by tightening the two mounting screws.

5-13. REPLACING THE RELAY. Remove soldered wire leads one at a time, reconnecting each lead immediately to the proper terminal of the replacement relay. Remove two mounting screws.

a. Mount replacement relay by replacing the two mounting screws and resoldering wire leads.

SECTION VI

ILLUSTRATED PARTS BREAKDOWN

6-1. GENERAL. This illustrated parts breakdown represents a typical keyboard and incorporates the complete parts for any style or arrangement for Model FK-2 Keyboards. In ordering spares, include the keyboard

serial number or the original contract number by which the keyboard was ordered. With this information and the index number as indicated in the exploded view, we will be able to supply spares for the particular keyboard in question.

FIGURE NO.	INDEX NO.	DESCRIPTION	UNITS PER ASSY
6-1	1	KEY PLATE	1
	2	KEY, Button	Up to 64
	3	INSERT, Grommet	4
	4	GROMMET	4
	5	SUPPORT, Key Plate - L.H. Rear	1
	6	SUPPORT, Key Plate - R.H. Rear	1
	7	HANGER, Key Spring - Rear	1
	8	NUT, Clinch	5
	9	STOP, Interlock Slide	1
	10	RETAINER, Code Bar	1
	11	FRAME, Left Side	1
	12	GUIDE, Code Bar - Bottom - L.H.	1

Section VI

FIGURE NO.	INDEX NO.	DESCRIPTION	UNITS PER ASSY
6-1	13	HANGER, Key Springs - Front	1
	14	SUPPORT, Key Plate - L.H. Front	1
	15	FRAME, Key Guide - Top	1
	16	SUPPORT, Solenoid	1
	17	TAPER PIN, Receptacle	2
	18	SOLENOID	1
	19	SPRING, Code Bar Reset	1
	20	SPRING, Key Reset	Up to 64
	21	SPRING, Interlock Slide	1
	22	BUSHING, Solenoid Drive Pin	1
	23	SUPPORT, Key Plate - R.H. Front	1
	24	BALL, Interlock	Up to 60
	25	RETAINER, Interlock Balls	1
	26	PLATE, Coding Contact	1
	27	PUSHER, Coding Contacts	9
	28	SWITCH, Solenoid	1
	29	SWITCH, Contact Coding	Up to 8
	30	KEY, Rows 1 and 4	Up to 23
	31	INSERT, Key Guide	Up to 130
	32	KEY, Rows 2 and 3	Up to 23
	33	BAR, Code	Up to 8
	34	SPRING, Code Bar	Up to 8
	35	SLIDE, Interlock	1
	36	SPACER, Relay	2
	37	RELAY, Antirepeat	1
	38	GUIDE, Code Bar - Center	As reqd.
	39	GUIDE, Code Bar - Bottom - R.H.	1
	40	FRAME, Key Guide - Bottom	1
	41	GUIDE, Code Bar - Top	1
	42	RING, Retaining	4
	43	BUSHING, Reset Bail	4
	44	SHAFT, Spring Hanger	1
	45	SHAFT, Reset Bail	1
	46	BAIL, Code Bar Reset	1
	47	SPACER	2
	48	HANGER, Code Bar Spring	1
	49	CONTACT, Common	1
	50	BRACKET, Common Contact	1
	51	GUIDE, Space Bar - Top	1
	52	BAR, Space	1
	53	SUPPORT, Equalizer - L.H.	1
	54	KEY, Space Bar	1
	55	GUIDE, Space Bar - Bottom	2
	56	BRACKET, Space Bar	2
	57	CODE SELECTOR, Space	1
	58	EQUALIZER, Space Keys	1
	59	SUPPORT, Equalizer - R.H.	1
	60	CAPACITOR, 0.25 uf, +20%, 600 V	1
	61	RESISTOR, 33 ohms, +20%, 1 watt	1
	62	STANDOFF, Insulated	3
	63	PLATE, RC Suppression	1
	64	CONNECTOR, Electrical	1
	65	BRACKET, Connector	1
	66	SETSCREW	1

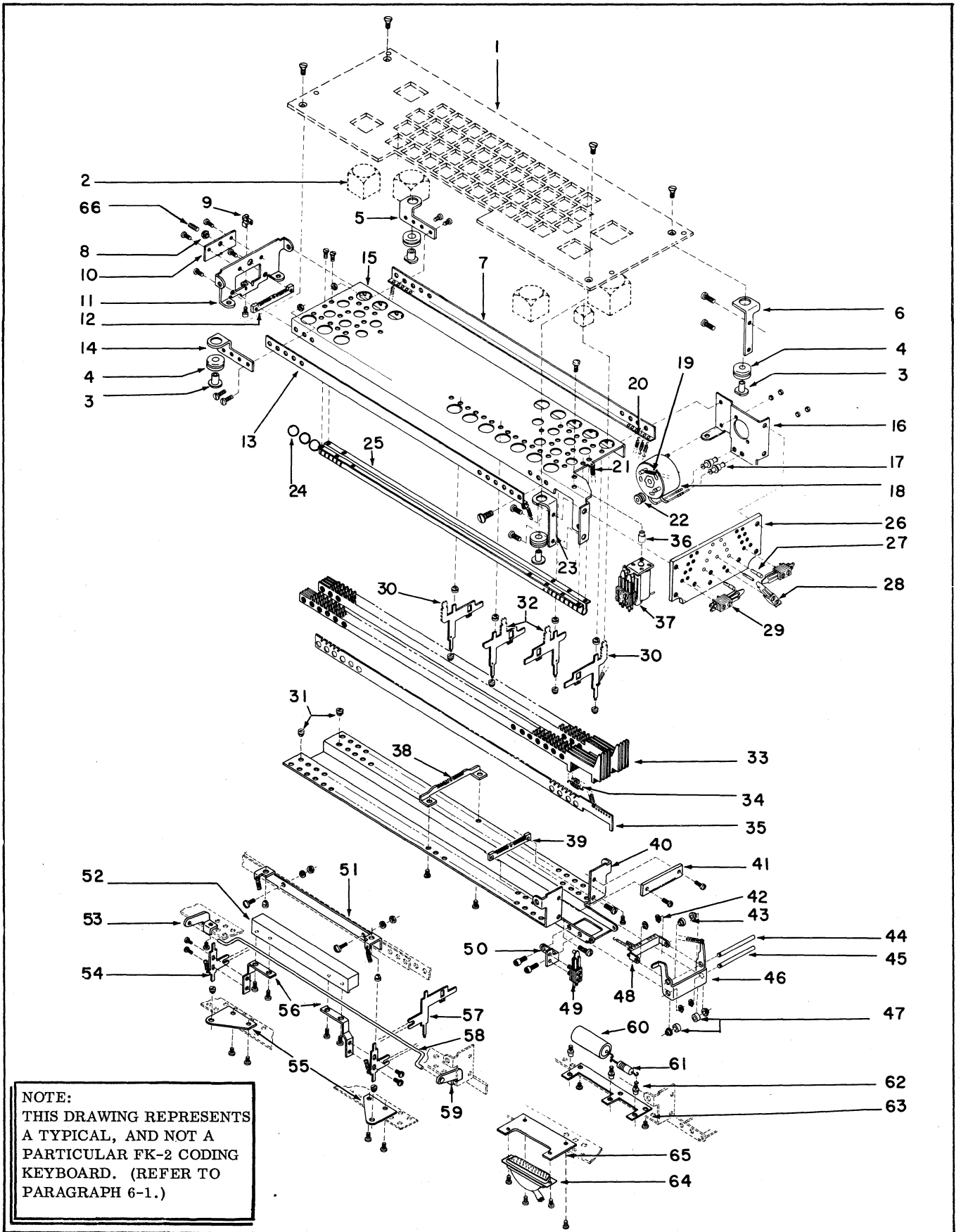

Figure 6-1. Automatic Coding Keyboard, Exploded View

SOROBAN ENGINEERING, INC.
Box 117
Melbourne, Florida

Bulletin TF-1

TECHNICAL NOTES
ON
MODEL FK-104 CODED AUTOMATIC KEYBOARD

The Model FK-104 Coded Automatic Keyboard is a new and versatile manually operated electro-mechanical device for producing parallel electrical pulse codes. It is a compact and portable unit housed in a light-weight and durable cast aluminum case. Available to the operator are twenty-one keys used to produce codes for numbers 0 through 9; letters a through f; decimal, plus, and minus characters; and tabulate and carriage return typewriter functions. Also included are an on-off switch and indicator light plus an inter-connecting plug for connection to the actuated mechanism.

In addition to the pulse coded output, one of the most significant features inherent in the keyboard design is a mechanical keyboard inter-lock. This feature permits one and only one key to be depressed at a given time. Moreover, once a key has been depressed, all keys are locked in their respective positions until a control signal is received signifying receipt of the selected code by the actuated mechanism.

The code is formed by means of a mechanical matrix consisting of six spring-loaded permutation bars operated by a solenoid controlled restoring bail. One distinct advantage of this technique is that it permits high contact pressure with low key operating force and thus insures positive code production. The minimum duration of the output pulse may be controlled from either a pre-determined internal time constant or an external feed-back pulse from the driven unit. This feed-back or timing-pulse indicator also energizes an anti-repeat relay which prevents multiple output from any single operation.

Bulletin TF-1

The keyboard uses a 1-2-4-8- binary code to indicate numbers and letters. Code designations for the remaining functions include the 1st and 6th teletype code positions as illustrated below.

SAMPLE TELETYPE CODE DESIGNATION

6 1 2 3 4 5 - Code Position
 2^5 2^4 2^3 2^2 2^1 2^0 - Binary Weight

Keyboard Function -----

Zero	0	0	0	0	0	0
1	0	0	0	0	0	1
2	0	0	0	0	1	0
3	0	0	0	0	1	1
4	0	0	0	1	0	0
5	0	0	0	1	0	1
6	0	0	0	1	1	0
7	0	0	0	1	1	1
8	0	0	1	0	0	0
9	0	0	1	0	0	1
a	0	0	1	0	1	0
b	0	0	1	0	1	1
c	0	0	1	1	0	0
d	0	0	1	1	0	1
e	0	0	1	1	1	0
f	0	0	1	1	1	1
/ (plus)	0	1	0	0	0	0
- (minus)	0	1	1	0	0	0
. (decimal)	0	1	0	1	0	0
CR (carriage return)	1	1	0	1	0	1
Tab (tabulate)	1	1	0	0	0	1

Bulletin TF-1

The Model FK-104 is designed to accommodate any keyboard configuration up to 22 keys and is capable of producing any type of binary code. Other models can be supplied to include any desired number of keys up to 64 with any desired code of six binary digits or less (i.e. binary, decimal, binary-coded decimal, or combinations thereof). It also is possible to incorporate into all models at slight additional cost, such other special features as:

- a. automatic digit counting
- b. automatic insertion of end of word indication
- c. automatic filling in of words
- ✓ d. Comparator-wherein simultaneous operation of the keyboard together with a companion tape reader and punch, automatically produces a verified tape output.

SPECIFICATIONS

Size	Height, 4 inches - width, 5½ inches - depth, 8 inches
Weight	Less than 5 lbs.
Finish	Royal-grey fine wrinkle
Input	Operable from any selected voltage between 6 VDC and 100 VDC, unfiltered
Total Output Load	Unsuppressed, 100 watts AC, but not more than 2 amps., with non-inductive load
Key Pressure	3½ oz. (can be varied to order)
Speed	Limited only by driven mechanism
Coding	6 digits plus common - mechanically produced
Electrical coding contacts	Bifurcated leafs using palladium contacts - 30 grams minimum force - Type A or C
Electrical common contact	Bifurcated leaf using tungsten contacts - Type A or C