

MODELS MP-F53W • MP-F53W-00D

PRODUCT SPECIFICATIONS

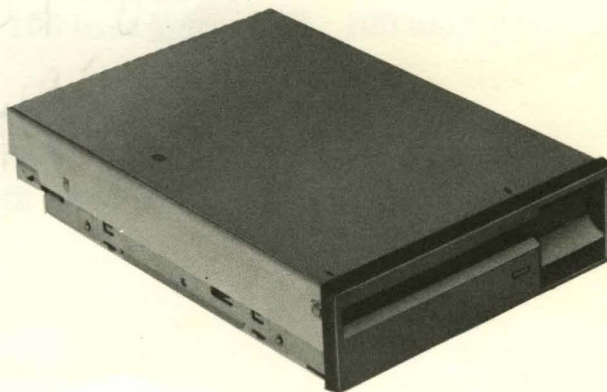

SONY®

CORRECT SHEET

<u>Page</u>	<u>Section</u>	<u>Wrong description</u>	<u>Correct description</u>
3-4	3-4-1	T1 : <u>0.5</u> usec <u>Min.</u>	T1 : <u>1.5</u> usec <u>Min.</u>
3-5	3-4-3	T4 : 0.5 usec <u>Max.</u>	T4 : 0.5 usec <u>Min.</u>
		*1 T6 : 8 usec <u>Max.</u>	T6 : 8 usec <u>Min.</u>
		*2 T6 : 4 usec <u>Max.</u>	T6 : 4 usec <u>Min.</u>
		T8 : 895 <u>sec</u> <u>Min.</u>	T8 : 895 <u>usec</u> <u>Min</u>
3-6	3-4-4		

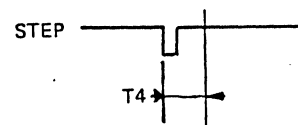
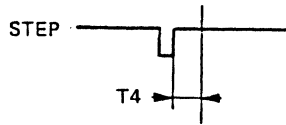

	T1 : 0.5 usec <u>Min.</u>	T1 : 0.5 usec <u>Max.</u>
*1	T5 : 925 <u>msec</u> <u>Min.</u>	T5 : 925 <u>usec</u> <u>Max.</u>
*2	T5 : 480 <u>msec</u> <u>Min.</u>	T5 : 480 <u>usec</u> <u>Max.</u>
	T6 : 100 usec <u>Min.</u>	T6 : 100 usec <u>Max.</u>

N.B. *1 for MP-F53W/ MP-F53W-00D only
 *2 for MP-F52W only
 Others are for both specs

PROPRIETARY NOTICE

This manual contains proprietary design information. Reproduction or dissemination of information provided herein, for purposes other than operation and maintenance of the equipment, is strictly prohibited without written consent from the SONY Corporation.

TABLE OF CONTENTS

<u>Description</u>	<u>Page</u>
SECTION 1. INTRODUCTION	1-1
SECTION 2. DRIVE DIMENSION AND PERFORMANCE	2-1
2-1. CONFIGURATION	2-1
2-2. PHYSICAL DIMENSIONS	2-1
2-3. PERFORMANCE	2-2
2-3-1. Capacity	2-2
2-3-2. Transfer Rate	2-2
2-3-3. Access Time	2-2
2-3-4. Functional	2-2
2-3-5. Reliability	2-2
2-4. INPUT POWER REQUIREMENTS	2-2
2-4-1. Power Consumption	2-2
2-4-2. Supply Voltages	2-3
2-5. ENVIRONMENTAL LIMITS	2-3
2-5-1. Temperature Range	2-3
2-5-2. Humidity Range	2-3
2-5-3. Vibration	2-3
2-5-4. Shock	2-4
2-5-5. Orientation	2-4
SECTION 3. SIGNAL INTERFACE	3-1
3-1. CONNECTOR AND PIN ASSIGNMENTS	3-1
3-1-1. Signal Connector Pin Assignment	3-1
3-1-2. Power Supply Connector	3-1
3-1-3. Power Supply Connector Pin Assignment	3-1
3-1-4. Power and Signal Connection Pin Numbers	3-1
3-1-5. Signal connector	3-1
3-1-6. Drive Select Switch	3-1
3-2. DC CHARACTERISTICS OF INTERFACE SIGNALS	3-1
3-2-1. Output Signals from Drive	3-1
3-2-2. Input Signals to Drive	3-2
3-2-3. Recommended Circuit for Signal Interface	3-2
3-3. SIGNAL DEFINITIONS	3-3
3-3-1. DRIVE SELECT 0,1,2,3	3-3
3-3-2. STEP	3-3
3-3-3. DIRECTION	3-3
3-3-4. HEAD SELECT	3-3
3-3-5. WRITE GATE	3-3
3-3-6. WRITE DATA	3-3
3-3-7. INDEX	3-3
3-3-8. TRACK 00	3-3
3-3-9. WRITE PROTECT	3-3
3-3-10. READ DATA	3-3
3-3-11. DISK CHANGE	3-3
3-3-12. DISK CHANGE RESET	3-4

TABLE OF CONTENTS

<u>Description</u>	<u>Page</u>
3-3-13. READY	3-4
3-3-14. MOTOR ON	3-4
3-3-15. IN USE	3-4
3-4. TIMING REQUIREMENTS	3-4
3-4-1. Head Access	3-4
3-4-2. TRACK 00 Signal	3-5
3-4-3. Write Data Timing	3-5
3-4-4. Read Data Timing	3-6
3-4-5. Index Pulse	3-6
3-4-6. Disk Change	3-7
3-5. POWER ON AND POWER OFF REQUIREMENTS	3-7
3-5-1. Data Protection	3-7
3-5-2. Power Supply Sequencing	3-7
3-5-3. Power On Reset Timing	3-7
3-6. DISK MOTOR ROTATION AND DISK INSERTION	3-7
SECTION 4. POWER ON INITIALIZATION	4-1
SECTION 5. READY SENSING METHOD	5-1
SECTION 6. SIGNAL GROUND TO FRAME GROUND SHORT	6-1
SECTION 7. TEST POINTS	7-1

SECTION 1

INTRODUCTION

This manual covers all drives with the model number of MP-F53W i.e. the MP-F53W-00D and the standard MP-F53W. While both drives are completely comprised of CMOS circuitry, the MP-F53W-00D has a TTL compatible interface while the standard MP-F53W's interface is CMOS. The specifications for these drives are identical except where indicated.

The main features of the MP-F53W series are: low power consumption, low height and high reliability with simple mechanism and electronic circuit.

MP-F53W series also complies with the following product safety standards :

U.L. 478

C.S.A. C22.2 No.154

U.L. 94V-0 for Front Panel (approved)

NB : The specifications defined in this booklet are valid if the drive is used with Sony media or any other ANSI specification media agreed upon by Sony and the drive customer.

SECTION 2

DRIVE DIMENSION AND PERFORMANCE

2-1. CONFIGURATION

The drive consists of a Read/Write head, head positioning mechanism, disk motor, interface logic circuit and Read/Write circuit.

2-2. PHYSICAL DIMENSIONS

The detailed physical dimensions are shown in Figure 2-1.

The main dimensions are:

Height	: 30mm (1.18in.)
Width	: 101.6mm (4.00in.)
Depth	: 150mm (5.91in.)
Weight	: 480g (1.06 pounds) Max.

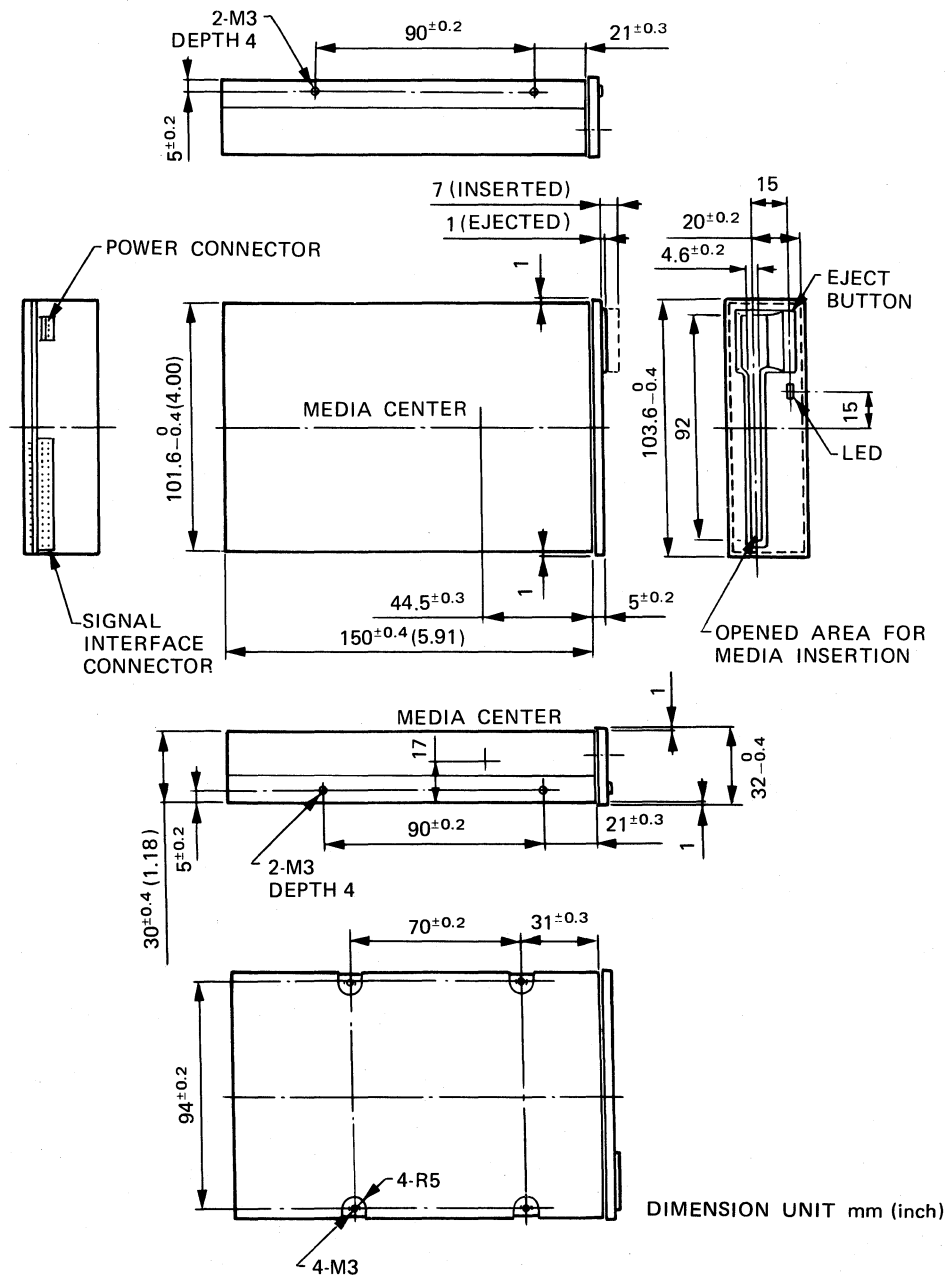

Figure 2-1. PHYSICAL DIMENSIONS

2-3. PERFORMANCE

2-3-1. Capacity

Unformatted Capacity : 1.0MB/disk for MFM
0.5MB/surface for MFM
6.25KB/track for MFM

2-3-2. Transfer Rate

Burst Transfer Rate : 250Kbits/sec for MFM

2-3-3. Access Time

a. Track to Track Slew Rate

: 6msec Min.

b. Track to Track Step Settling Time

: 15msec Max.

The value of 15msec is the time necessary to stabilize the head within 0.035mm of its absolute position.

c. Motor Start Time : 900msec Max.

Motor start time is the time that it takes for the READY signal to become true (low) after the MOTOR ON signal has been activated.

2-3-4. Functional

a. Rotation Speed : 300rpm

The continuous speed variation is within $\pm 1.5\%$.
The instantaneous speed variation is within $\pm 1.0\%$.

b. Recording Density : 8717BPI (Side 1, Track 79)

c. Track Density : 0.1875mm (7.38×10^{-3} in.) Track - Track

d. Cylinders : 80
e. Tracks : 160
f. R/W Heads : 2

2-3-5. Reliability

a. Mean Time Between Failures (MTBF)
: 10,000 POH

b. Mean Time to Repair (MTTR)
: 30minutes

c. Preventive Maintenance (PM)
: Not Required

d. Components Life : 5 years or
15,000 POH

e. Error Rate

1. Soft Read Error : 1 per 10^9 bits read
2. Hard Read Error : 1 per 10^{12} bits read
3. Seek Error : 1 per 10^6 seeks

2-4. INPUT POWER REQUIREMENTS

2-4-1. Power Consumption

Model Name	MP-F53W	MP-F53W-000
Standby	50mW	255mW
Operation [Read/Write mode]	2.6W	2.85W

2-4-2. Supply Voltages

a. For Model MP-F53W

Voltage	Max. Ripple	Current
+12.0V±5%	0.1Vpp	Stand-by 10uA Average 130mA [Read] Peak 700mA [Motor Start] Peak 300mA [Stepping during Motor On]
+5.0V±5%	0.1Vpp	Stand-by 10mA Operating 200mA

b. For Model MP-F53W-00D

Voltage	Max. Ripple	Current
+12.0V±5%	0.1Vpp	Stand-by 10uA Average 130mA [Read] Peak 700mA [Motor Start] Peak 300mA [Stepping during Motor On]
+5.0V±5%	0.1Vpp	Stand-by 51mA Operating 241mA

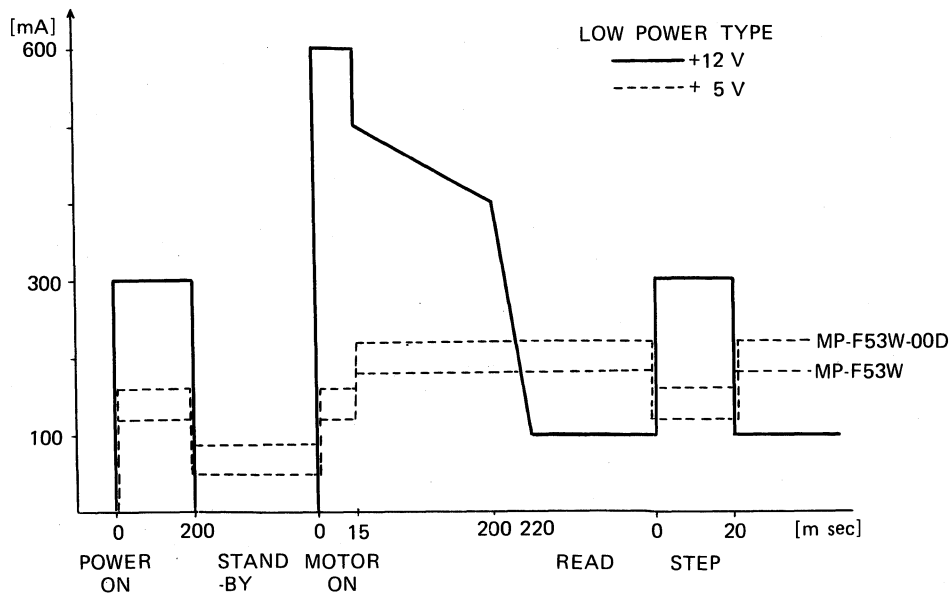

Figure 2-2. DC CURRENT PROFILE (AVERAGE)

2-5. ENVIRONMENTAL LIMITS

2-5-1. Temperature Range

Operating : 5°C to 50°C (40°F to 122°F)
ambient

Transportation

: -40°C to 60°C (-40°F to 140°F)

These figures are valid provided that there is no condensation.

Storage : -20°C to 60°C (-4°F to 140°F)

These figures are valid provided that there is no condensation.

2-5-2. Humidity Range

Operating : 8% to 80% relative humidity
with a wet bulb temperature of
29°C (85°F) and no condensation.

Transportation and Storage

: 5% to 95% relative humidity and
no condensation

2-5-3. Vibration

Operating : The unit can perform Read/Write operations without an error rate beyond that specified while withstanding continuous vibrations at a frequency of 10 to 500Hz with an acceleration of no more than 0.5G along each of the three mutually perpendicular axes.

Transportation and Storage

: The unit can withstand continuous vibrations from 10Hz to 300Hz with a maximum acceleration of 2.0G along each of the three mutually perpendicular axes without any degradation of any characteristics below the performance specifications.

2-5-4. Shock

Operating : The unit can withstand a 5.0G shock for 11msec with a 1/2 sine wave shape in each of the three mutually perpendicular axis while performing normal Read/Write functions without damage or any loss of data.

Transportation and Storage

: The unit when unpacked can withstand an 11msec with a 1/2 sine wave shock of 60G on any of the three mutually perpendicular axis.

2-5-5. Orientation

The drive does not necessarily need to be horizontally positioned. In fact, as seen in figure 2-3, there are many other possible orientations.

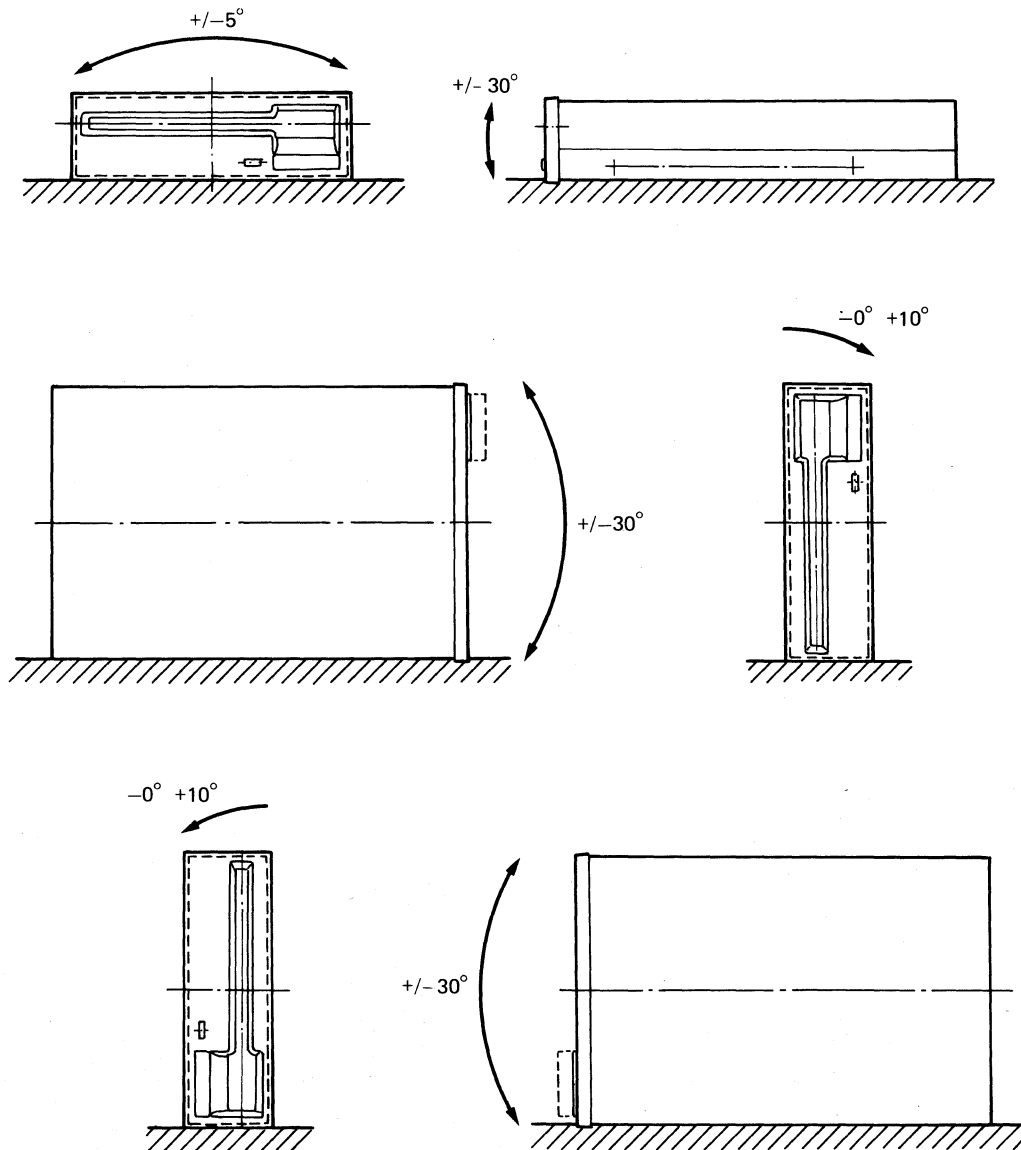

Figure 2-3. ORIENTATIONS

SECTION 3

SIGNAL INTERFACE

3-1. CONNECTOR AND PIN ASSIGNMENTS

3-1-1. Signal Connector Pin Assignment

PIN	SIGNAL DESCRIPTION	PIN	SIGNAL DESCRIPTION
1	DISK CHANGE RESET	2	DISK CHANGE
3	RETURN	4	IN USE
5	RETURN	6	DRIVE SELECT 3
7	RETURN	8	INDEX
9	RETURN	10	DRIVE SELECT 0
11	RETURN	12	DRIVE SELECT 1
13	RETURN	14	DRIVE SELECT 2
15	RETURN	16	MOTOR ON
17	RETURN	18	DIRECTION
19	RETURN	20	STEP
21	RETURN	22	WRITE DATA
23	RETURN	24	WRITE GATE
25	RETURN	26	TRACK 00
27	RETURN	28	WRITE PROTECT
29	RETURN	30	READ DATA
31	RETURN	32	HEAD SELECT
33	RETURN	34	READY

3-1-5. Signal connector

Receptacle : 3M 3414-6500xx or Equivalent

Cable : 3M 3365/34 or Equivalent

3-1-6. Drive Select Switch

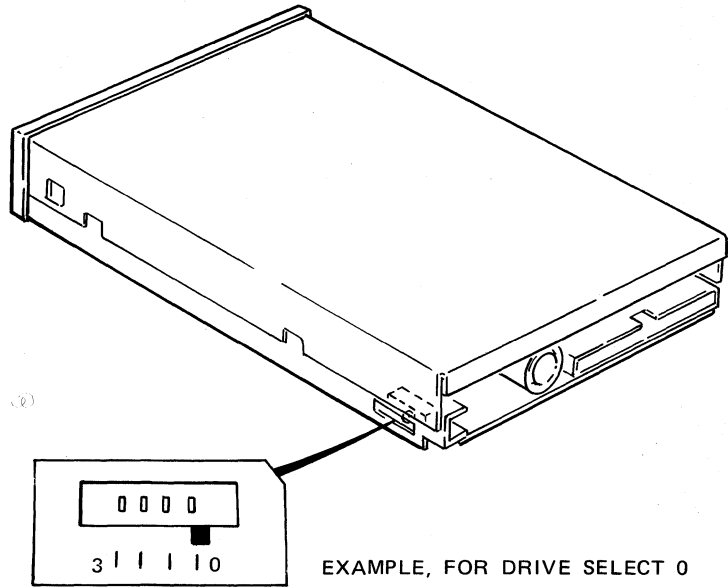

EXAMPLE, FOR DRIVE SELECT 0

3-1-2. Power Supply Connector

Receptacle : AMP 171822-4 or Equivalent

Contact : AMP 170262-1 or Equivalent

Wire : AWG 20

3-1-3. Power Supply Connector Pin Assignment

PIN	SIGNAL DESCRIPTION
1	+5V
2	GND (+5V Return)
3	GND (+12V Return)
4	+12V

3-1-4. Power and Signal Connection Pin Numbers

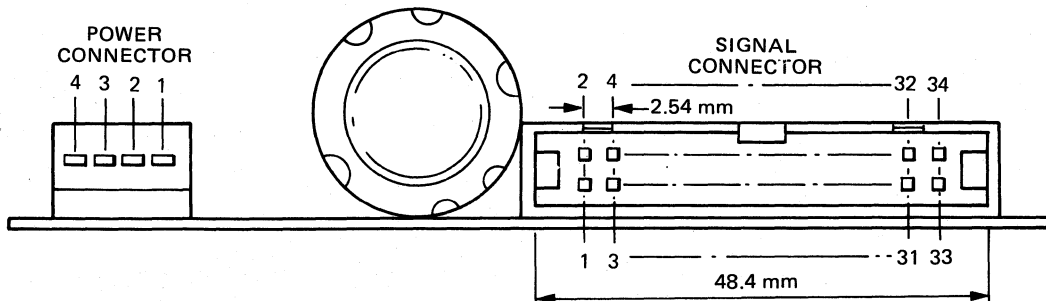

Figure 3-1. PIN ASSIGNMENT (REAR VIEW OF DRIVE)

Figure 3-2. DRIVE SELECT SWITCH

3-2. DC CHARACTERISTICS OF INTERFACE SIGNALS

3-2-1. Output Signals from Drive

Interface All output

	MP-F53W	MP-F53W-00D
True (low level)	0.0 to 0.4V	0.0 to 0.7V
output current	4.0mA	40mA
False (high level)	+2.4V to +5.0V	
output current	-1.0mA	250µA

3-2-2. Input Signals to Drive
Interface All Input

	MP-F53W	MP-F53W-00D
True (low level)	0.0 to +0.8V	0.0 to +0.8V
Input current	-0.6mA (at +0.4V)	-5.0mA (at +0.4V)
False (high level)	+2.2V to +5.0V	+2.2V to +5.0V
Input current	0.01mA (at +2.4V)	0.01mA (at +2.4V)

3-2-3. Recommended Circuit for Signal Interface :

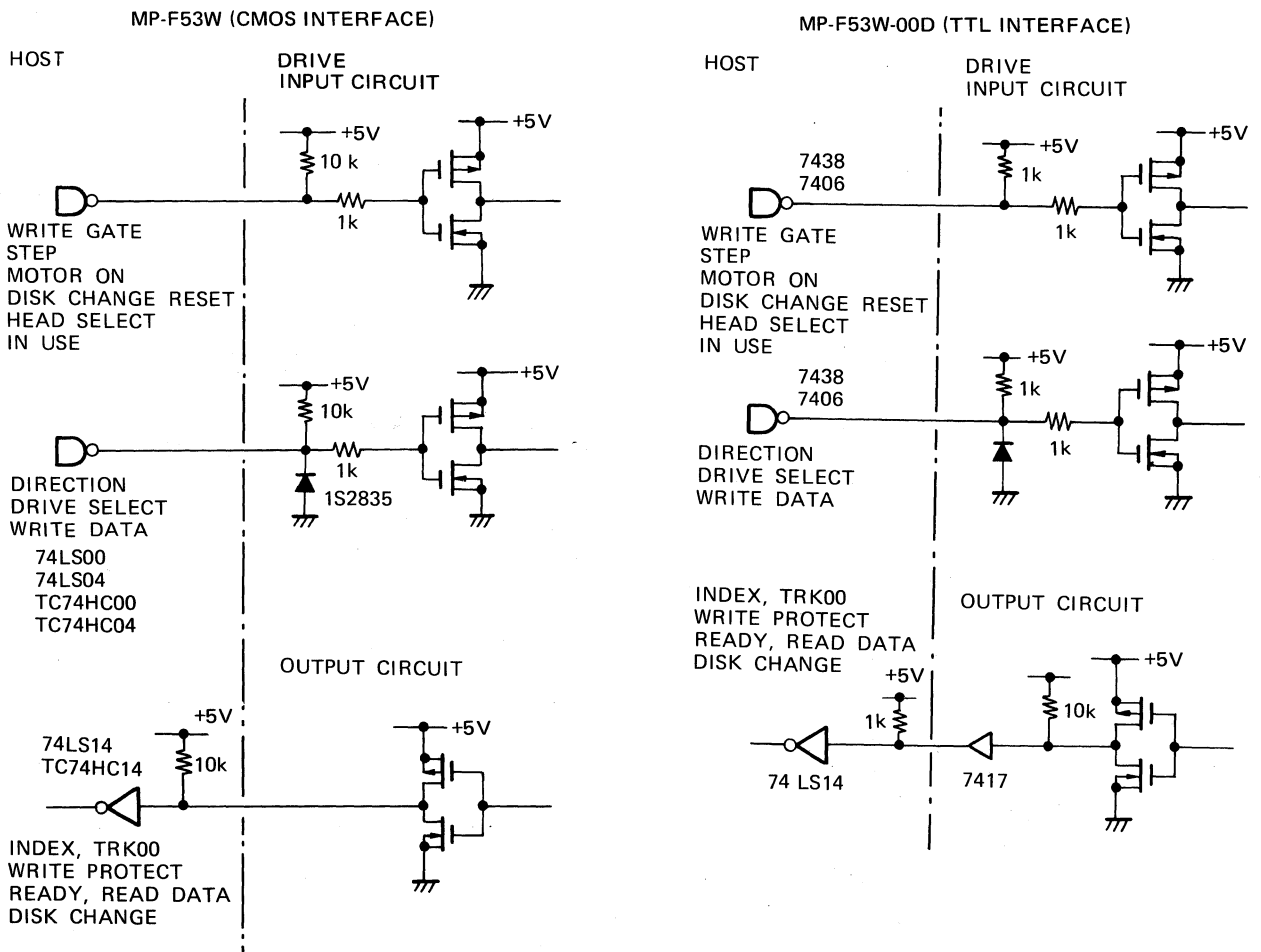

The line from the drive to the controller should be pulled up by a resistor of 10KΩ.

The cable length must be less than 50cm (19.7in.).

The line from the drive to the controller should be pulled up by a resistor of 1KΩ.

The cable length must be less than 1.5m (4.92in.).

Figure 3-3. INTERFACE CIRCUITY

3-3. SIGNAL DEFINITIONS

3-3-1. DRIVE SELECT 0,1,2,3

The SELECT lines are used to enable or disable all other interface lines. When the SELECT line is true (low), the drive is enabled and considered active. When the SELECT line is false (high), all controller inputs are ignored and all drive lines are disabled.

3-3-2. STEP

A true (low) pulse on this line will cause the Read/Write head to move to the adjacent track. The direction of the head movement is determined by the status of the DIRECTION signal at the time of stepping.

The step operation can be performed even if there is no disk inserted in the drive.

3-3-3. DIRECTION

A false (high) level on this input will cause a STEP pulse input to move the Read/Write head away from the disk spindle. A true (low) level will cause a STEP pulse input to move the Read/Write head toward the drive spindle.

3-3-4. HEAD SELECT

A true (low) level on this input will cause Head 1 (upper) to be selected. A false (high) level on this input will cause Head 0 (lower) to be selected. If the HEAD SELECT signal changes during either a write or erase operation, the head will not change until both the ERASE GATE and the WRITE GATE signal become false (high).

3-3-5. WRITE GATE

When this line is made true (low), the write current circuits are enabled and information may be written under control of the WRITE DATA input.

3-3-6. WRITE DATA

If the WRITE GATE signal is true (low), a true pulse (low) on the WRITE DATA line will cause a bit to be written on the disk. However, bits cannot be written from pulses on this line if the WRITE GATE signal is false (high).

No pre-compensation is required.

3-3-7. INDEX

When the drive is selected and the READY signal is true (low), a true (low) pulse is generated on this line by each revolution of the spindle.

3-3-8. TRACK 00

This line is true (low) when the Read/Write head is positioned on track 00 or on an outer position of track 00. At all other times it is false (high). The TRACK 00 signal derives its information from a track 00 sensor, not from the track position counter.

3-3-9. WRITE PROTECT

If a write protected disk is inserted, this line will be true (low) and the drive will not be able to write data. At all other times when the disk is inserted, this line will be false (high).

3-3-10. READ DATA

When the drive is selected and the READY signal is true (low), a true (low) pulse is generated on this line every time a bit is detected.

3-3-11. DISK CHANGE

This line is true (low) whenever a disk is removed from the selected drive. The line will remain true (low) until both the following conditions have been met:

- a. A disk is inserted,
and
- b. A STEP pulse or DISK CHANGE RESET signal has been received when the drive is selected.

3-3-12. DISK CHANGE RESET

If the DISK CHANGE RESET signal is true (low) and a disk is inserted, the DISK CHANGE line will be false (high).

3-3-13. READY

This line is true (low) when all of the following conditions are met.

- a. The drive is selected,
 - b. A disk is inserted,
 - c. The MOTOR ON signal is true (low),
- and
- d. The INDEX period of the disk motor settles within $200\text{msec} \pm 2.5\%$.

3-3-14. MOTOR ON

When this line is true (low) and a disk is inserted, the spindle motor will start to run. If this line is made false (high) or a disk is ejected, the spindle motor will stop. However, if the MOTOR ON signal becomes false (high) during either a write or erase operation, the disk motor will not stop rotating until both the ERASE GATE signal and the WRITE GATE signal become false (high).

3-3-15. IN USE

When this line is low and the drive is selected, the LED will turn on. When this line is high or the drive is not selected, the LED is off.

3-4. TIMING REQUIREMENTS

3-4-1. Head Access

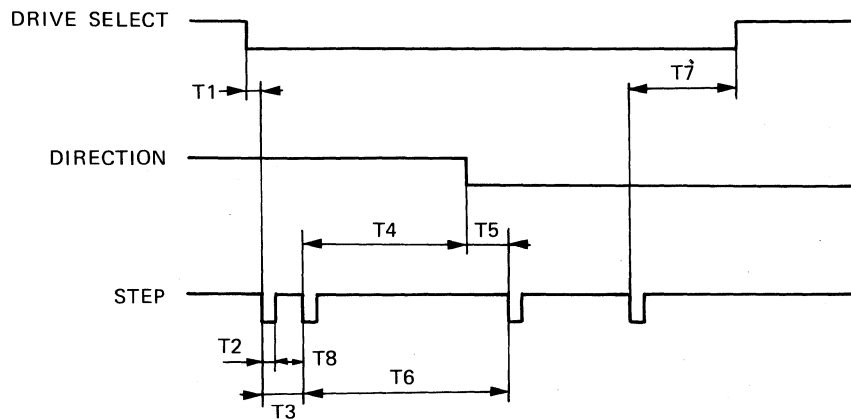

T1 : 0.5 μ sec Min.

T2 : 1.3 μ sec Min.

T3 : 6.0msec Min.

T4 : 2.4 μ sec Min.

T5 : 0.5 μ sec Min.

T6 : 21.0msec Min.

T7 : 0.5 μ sec Min.

T8 : 1.3 μ sec Min.

Figure 3-4. HEAD ACCESS

3-4-2. TRACK 00 Signal

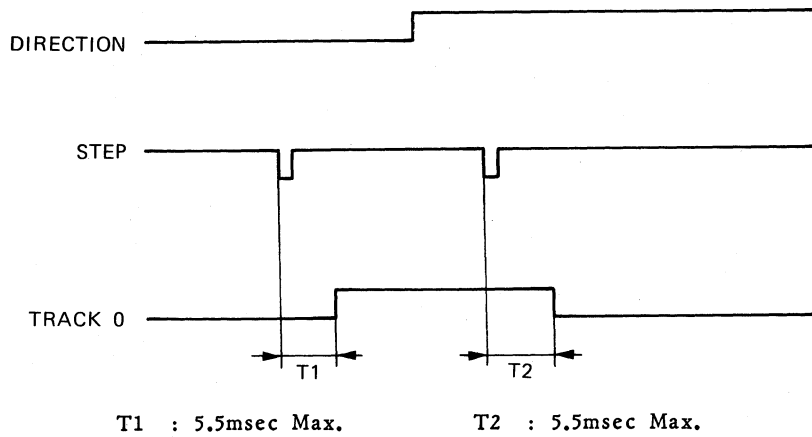

Figure 3-5. TRACK 00 SIGNAL

3-4-3. Write Data Timing

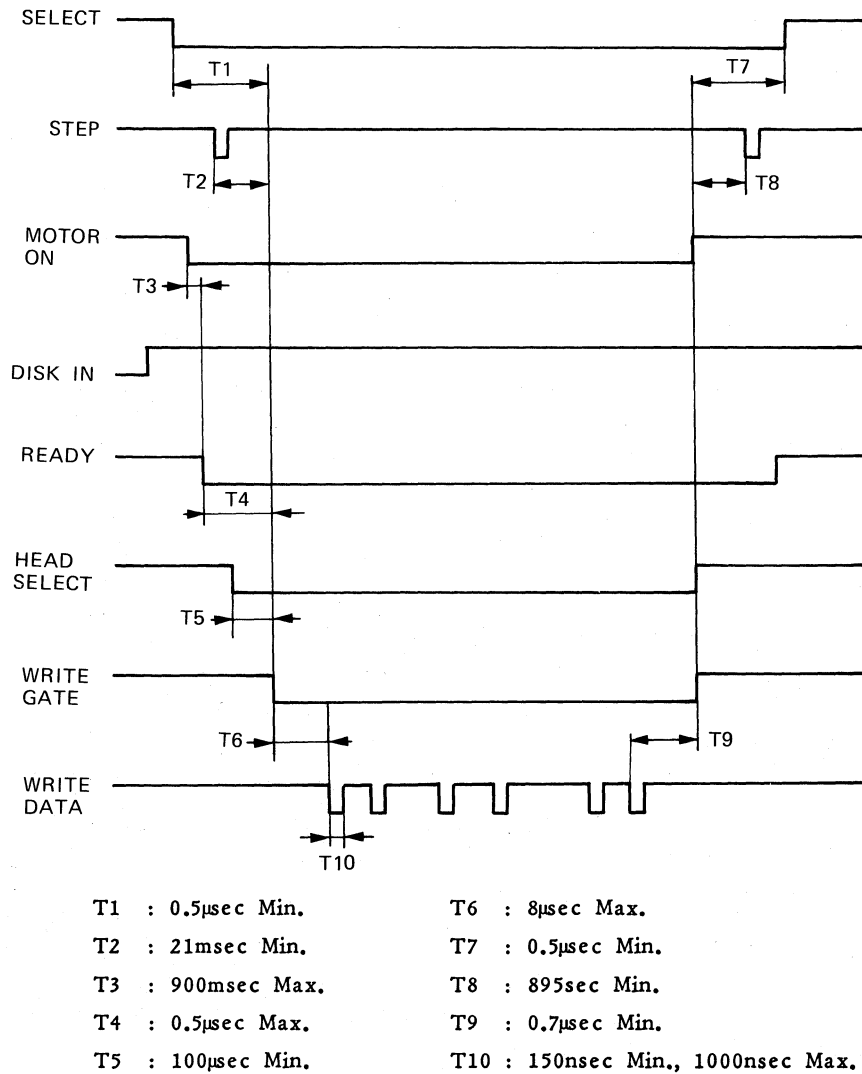
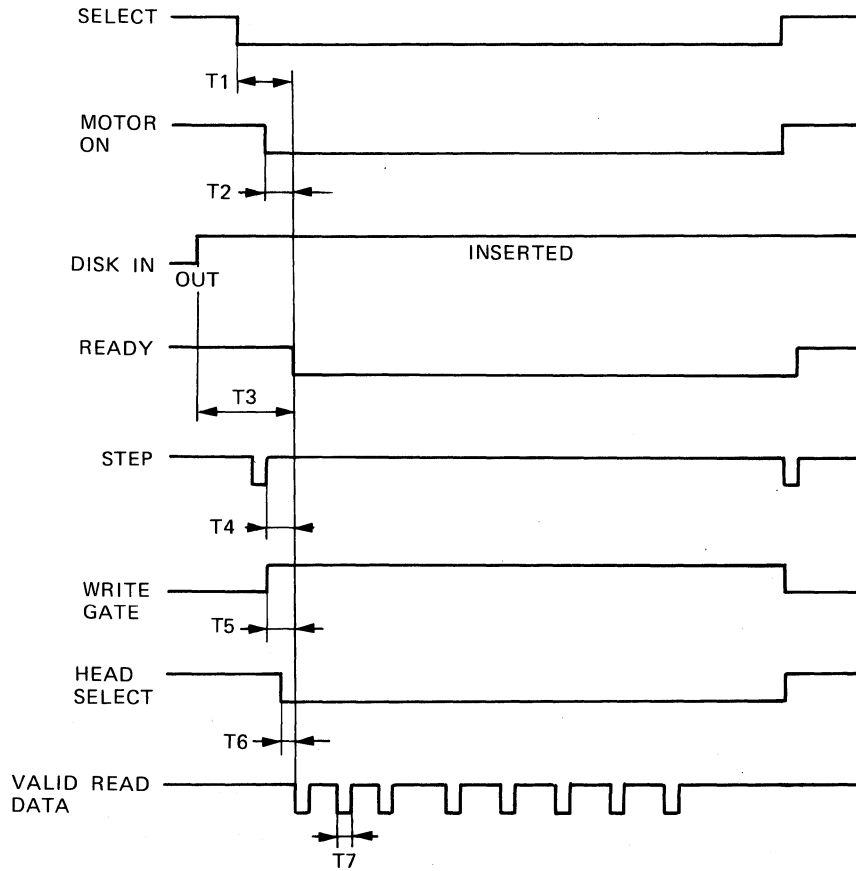

Figure 3-6. WRITE DATA TIMING

3-4-4. Read Data Timing



- | | |
|-------------------------|----------------------------------|
| T1 : 0.5 μ sec Min. | T5 : 925msec Min. |
| T2 : 900msec Max. | T6 : 100 μ sec Min. |
| T3 : 900msec Max. | T7 : 500nsec Min., 1200nsec Max. |
| T4 : 21msec Min. | |

Figure 3-7. READ DATA TIMING

3-4-5. Index Pulse

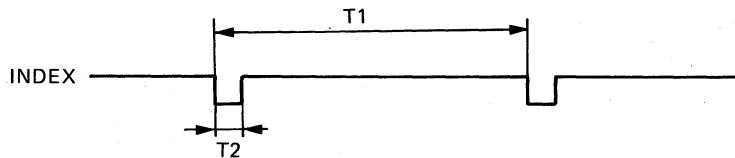

- | |
|---------------------------------------------|
| T1 : 197msec Min., 203msec Max. |
| T2 : 150 μ sec Min., 350 μ sec Max. |

Figure 3-8. INDEX PULSE

3-4-6. Disk Change

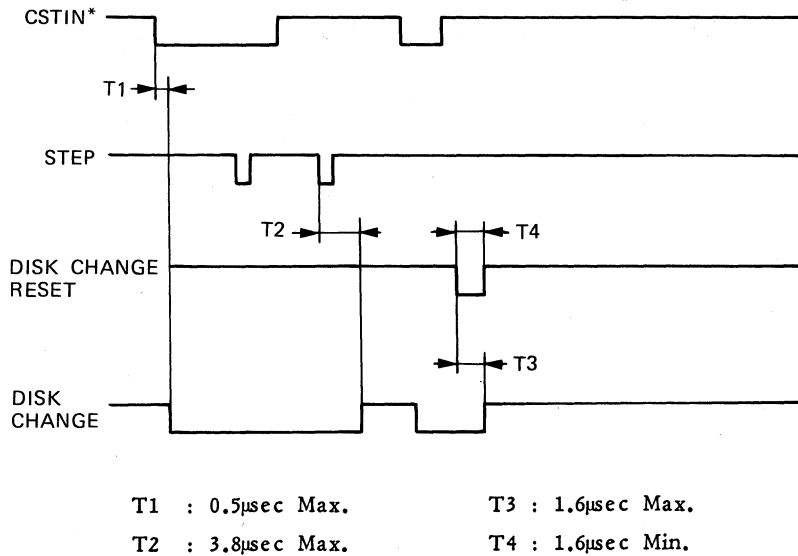

Figure 3-9. DISK CHANGE

*CSTIN, the disk-in sensor signal inside the drive, is high when a disk is inserted in the drive.

3-5. POWER ON AND POWER OFF REQUIREMENTS

3-5-1. Data Protection

Turning the power on or off will not cause any damage to recorded data on the disk as long as the drive is not in the midst of writing.

3-5-2. Power Supply Sequencing

No special supply sequencing is required by the disk drive as long as both the 5V and 12V power supplies have a monotonic rise time of less than 100msec. When the power is turned off, although there are no sequencing or timing requirements, both power supplies must fall monotonically to 0V.

3-5-3. Power On Reset Timing

Because it takes up to 200msec to reset the control IC after the power has been turned on, the MP-F53W cannot correctly perform any operations for this period of time.

3-6. DISK MOTOR ROTATION AND DISK INSERTION

Even if the MOTOR ON signal is true (low), the disk motor will not rotate until a disk is inserted.

SECTION 4 POWER ON INITIALIZATION

In order to reduce the peak current requirement when used in a daisy chain, the MP-F53W has been designed not to seek track 00 automatically.

If all the drives connected in the daisy chain sought track 00 simultaneously, this would place a significant power drain on the host system.

Thus, the host system must perform the following routine just after power on in order to reset the track counter inside the drive.

Power On Initialization

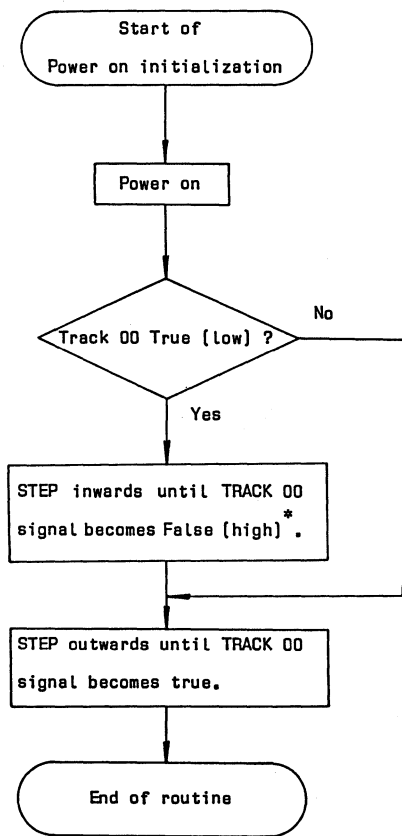

* Track 00 signal becomes false (high) by sending at minimum 20 STEP pulses (inwards) to the drive.

SECTION 5 READY SENSING METHOD

The following routine is recommended to shorten the waiting time and also permit the use of a disk which has a load torque that exceeds 50g-cm.

Recommended Method

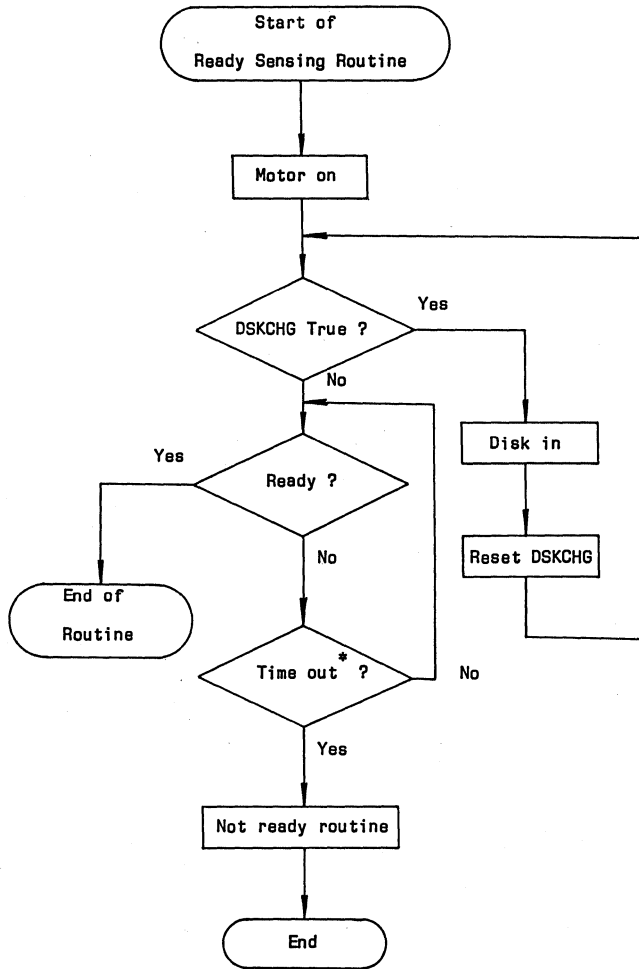

* The period until time out : Min. 3sec

As long as the load torque generated by the disk is not more than 50g-cm (ANSI specification, X3B8), the motor start time will not be more than 900msec. The conventional method of detecting when the READY signal becomes true is shown in the right column. Since this method only checks the status of the READY signal after 900msec have elapsed, a shorter motor start time cannot be achieved with this routine.

Conventional Method

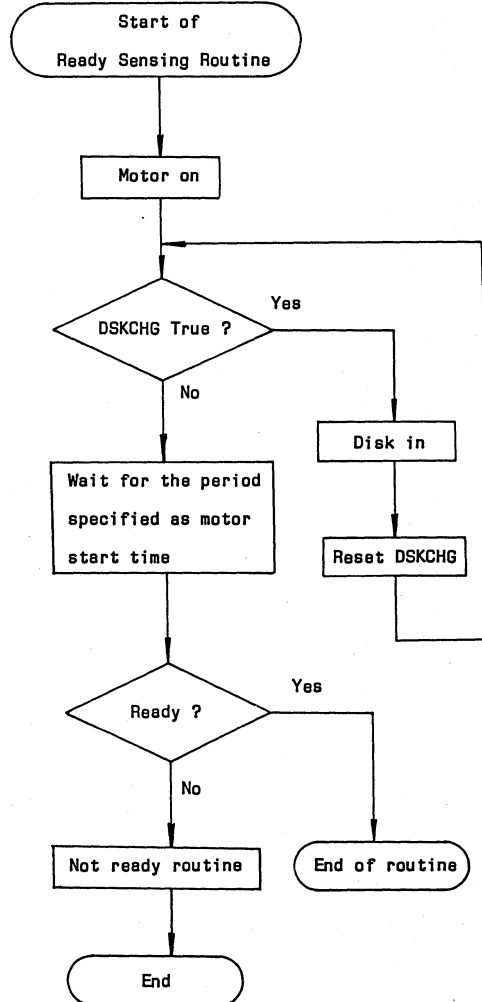

If the load torque is greater than 50g-cm then the conventional method of READY signal sensing will indicate "not ready" whenever it takes more than 900msec to achieve the specified rotation velocity.

SECTION 6

SIGNAL GROUND TO FRAME GROUND SHORT

A 100K Ω resistor and a 0.1pF capacitor are connected in parallel between signal ground and frame ground. In order to short signal ground to frame ground, attach the screw shown in figure 6-1.

The screw to be used is a Philips type,
2.5 (ISO)x6 (mm)
NB : pitch = 0.45 (mm)

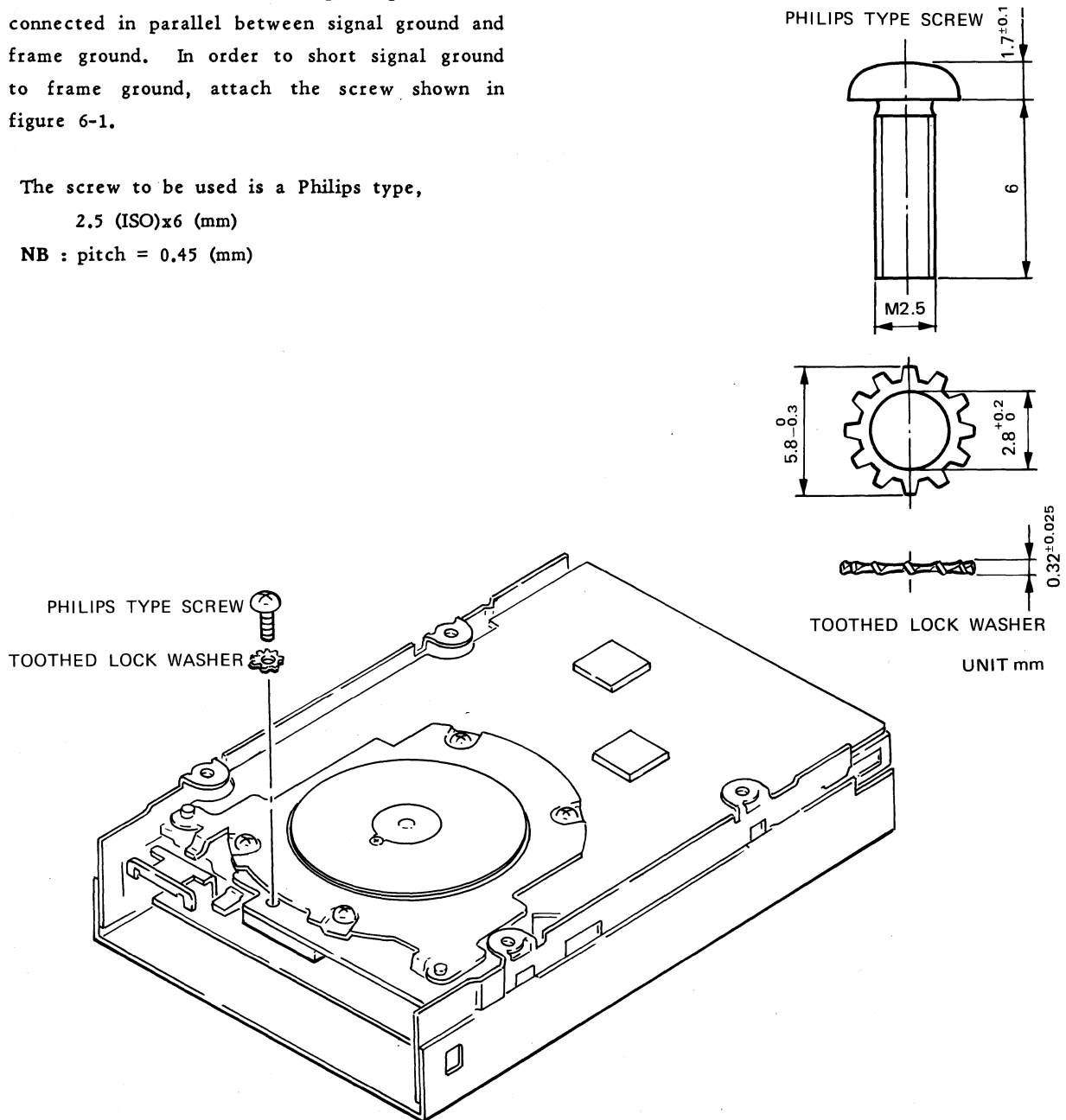

Figure 6-1. SG-FG SHORT

SECTION 7
TEST POINTS

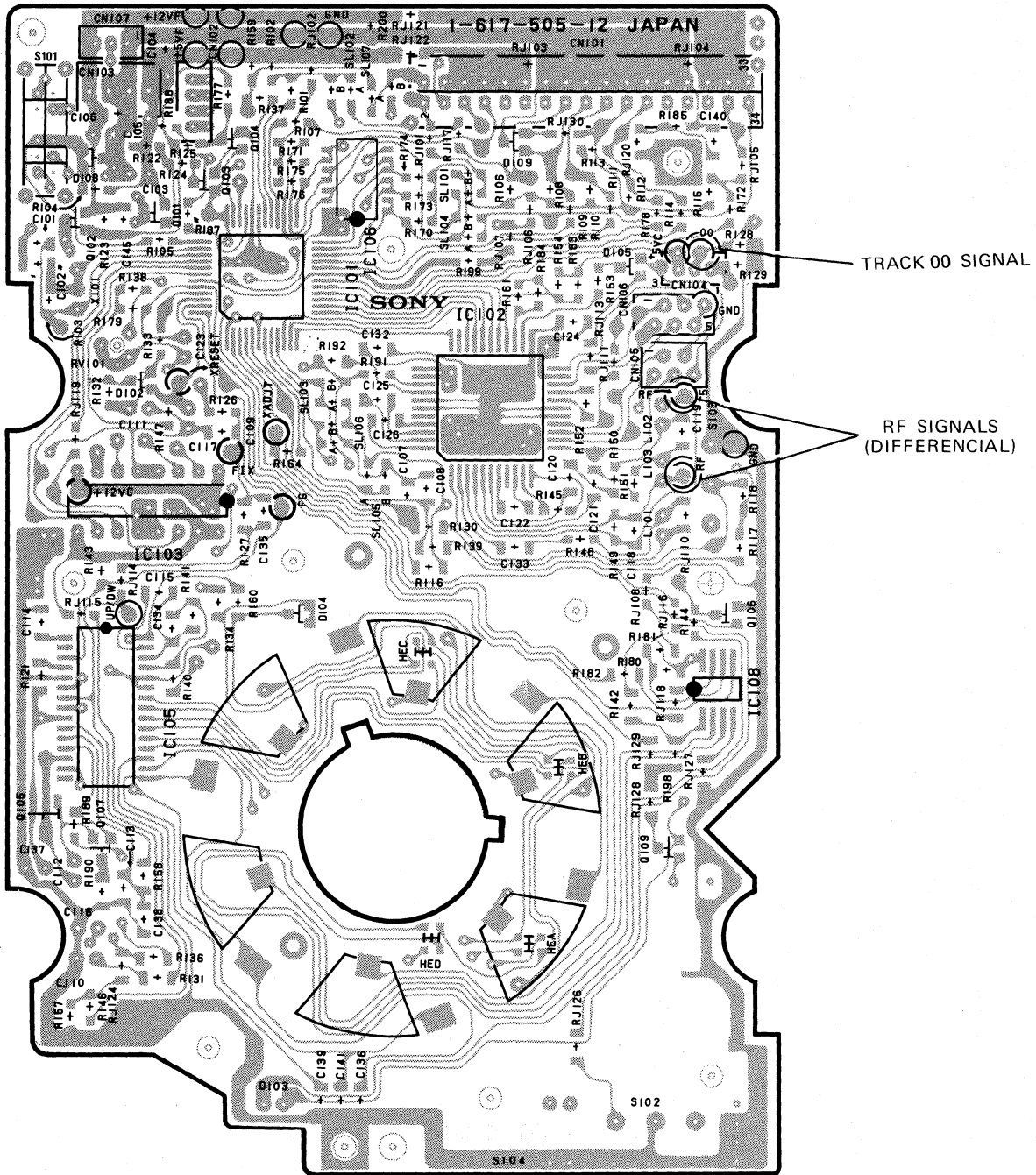

Figure 7-1. TEST POINTS

3.5inch MICRO FLOPPYDISK DRIVE

