

64000

**HP64000
Logic Development
System**

**Model 64340A
Software Analyzer**



CERTIFICATION

Hewlett-Packard Company certifies that this product met its published specifications at the time of shipment from the factory. Hewlett-Packard further certifies that its calibration measurements are traceable to the United States National Bureau of Standards, to the extent allowed by the Bureau's calibration facility, and to the calibration facilities of other International Standards Organization members.

WARRANTY

This Hewlett-Packard system product is warranted against defects in materials and workmanship for a period of 90 days from date of installation. During the warranty period, HP will, at its options, either repair or replace products which prove to be defective.

Warranty service of this product will be performed at Buyer's facility at no charge within HP service travel areas. Outside HP service travel areas, warranty service will be performed at Buyer's facility only upon HP's prior agreement and Buyer shall pay HP's round trip travel expenses. In all other cases, products must be returned to a service facility designated by HP.

For products returned to HP for warranty service, Buyer shall prepay shipping charges to HP and HP shall pay shipping charges to return the product to Buyer. However, Buyer shall pay all shipping charges, duties, and taxes for products returned to HP from another country.

HP warrants that its software and firmware designated by HP for use with an instrument will execute its programming instructions when properly installed on that instrument. HP does not warrant that the operation of the instrument, or software, or firmware will be uninterrupted or error free.

LIMITATION OF WARRANTY

The foregoing warranty shall not apply to defects resulting from improper or inadequate maintenance by Buyer, Buyer-supplied software or interfacing, unauthorized modification or misuse, operation outside the environmental specifications for the product, or improper site preparation or maintenance.

NO OTHER WARRANTY IS EXPRESSED OR IMPLIED. HP SPECIFICALLY DISCLAIMS THE IMPLIED WARRANTIES OF MERCHANTABILITY AND FITNESS FOR A PARTICULAR PURPOSE.

EXCLUSIVE REMEDIES

THE REMEDIES PROVIDED HEREIN ARE BUYER'S SOLE AND EXCLUSIVE REMEDIES. HP SHALL NOT BE LIABLE FOR ANY DIRECT, INDIRECT, SPECIAL, INCIDENTAL, OR CONSEQUENTIAL DAMAGES, WHETHER BASED ON CONTRACT, TORT, OR ANY OTHER LEGAL THEORY.

ASSISTANCE

Product maintenance agreements and other customer assistance agreements are available for Hewlett-Packard products.

For any assistance, contact your nearest Hewlett-Packard Sales and Service Office. Addresses are provided at the back of this manual.

FOLD HERE



NO POSTAGE
NECESSARY
IF MAILED
IN THE
UNITED STATES

BUSINESS REPLY CARD

FIRST CLASS PERMIT NO. 1303 COLORADO SPRINGS, COLORADO

POSTAGE WILL BE PAID BY ADDRESSEE

HEWLETT-PACKARD

Logic Product Support Dept.
Attn: Technical Publications Manager
Centennial Annex - D2
P.O. Box 617
Colorado Springs, Colorado 80901-0617

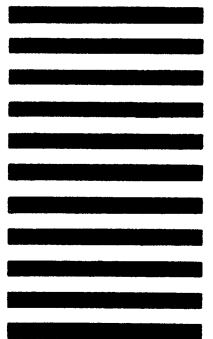

FOLD HERE

Your cooperation in completing and returning this form
will be greatly appreciated. Thank you.

READER COMMENT SHEET

Service Manual
Model 64340A, Software Analyzer
64340-90901, December 1984

Your comments are important to us. Please answer this questionnaire and return it to us. Circle the number that best describes your answer in questions 1 through 7. Thank you.

1. The information in this book is complete:

Doesn't cover enough
(what more do you need?)

1 2 3 4 5

Covers everything

2. The information in this book is accurate:

Too many errors

1 2 3 4 5

Exactly right

3. The information in this book is easy to find:

I can't find things I need

1 2 3 4 5

I can find info quickly

4. The Index and Table of Contents are useful:

Helpful

1 2 3 4 5

Missing or inadequate

5. What about the "how-to" procedures and examples:

No help

1 2 3 4 5

Very helpful

Too many now

1 2 3 4 5

I'd like more

6. What about the writing style:

Confusing

1 2 3 4 5

Clear

7. What about organization of the book:

Poor order

1 2 3 4 5

Good order

8. What about the size of the book:

too big/small

1 2 3 4 5

Right size

Comments: _____

Particular pages with errors?

Name (optional): _____

Job title: _____

Company: _____

Address: _____

Note: If mailed outside U.S.A., place card in envelope. Use address shown on other side of this card.

FOLD HERE



NO POSTAGE
NECESSARY
IF MAILED
IN THE
UNITED STATES

BUSINESS REPLY CARD

FIRST CLASS PERMIT NO. 1303 COLORADO SPRINGS, COLORADO

POSTAGE WILL BE PAID BY ADDRESSEE

HEWLETT-PACKARD

Logic Product Support Dept.
Attn: Technical Publications Manager
Centennial Annex - D2
P.O. Box 617
Colorado Springs, Colorado 80901-0617

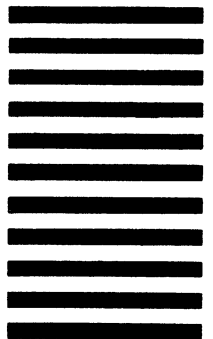

FOLD HERE

Your cooperation in completing and returning this form
will be greatly appreciated. Thank you.

READER COMMENT SHEET

Service Manual
Model 64340A, Software Analyzer
64340-90901, December 1984

Your comments are important to us. Please answer this questionnaire and return it to us. Circle the number that best describes your answer in questions 1 through 7. Thank you.

1. The information in this book is complete:

Doesn't cover enough
(what more do you need?)

1 2 3 4 5

Covers everything

2. The information in this book is accurate:

Too many errors

1 2 3 4 5

Exactly right

3. The information in this book is easy to find:

I can't find things I need

1 2 3 4 5

I can find info quickly

4. The Index and Table of Contents are useful:

Helpful

1 2 3 4 5

Missing or inadequate

5. What about the "how-to" procedures and examples:

No help

1 2 3 4 5

Very helpful

Too many now

1 2 3 4 5

I'd like more

6. What about the writing style:

Confusing

1 2 3 4 5

Clear

7. What about organization of the book:

Poor order

1 2 3 4 5

Good order

8. What about the size of the book:

too big/small

1 2 3 4 5

Right size

Comments: _____

Particular pages with errors?

Name (optional): _____

Job title: _____

Company: _____

Address: _____

Note: If mailed outside U.S.A., place card in envelope. Use address shown on other side of this card.

SAFETY SUMMARY

The following general safety precautions must be observed during all phases of operation, service, and repair of this instrument. Failure to comply with these precautions or with specific warnings elsewhere in this manual violates safety standards of design, manufacture, and intended use of the instrument. Hewlett-Packard Company assumes no liability for the customer's failure to comply with these requirements.

GROUND THE INSTRUMENT.

To minimize shock hazard, the instrument chassis and cabinet must be connected to an electrical ground. The instrument is equipped with a three-conductor ac power cable. The power cable must either be plugged into an approved three-contact electrical outlet or used with a three-contact to two-contact adapter with the grounding wire (green) firmly connected to an electrical ground (safety ground) at the power outlet. The power jack and mating plug of the power cable meet International Electrotechnical Commission (IEC) safety standards.

DO NOT OPERATE IN AN EXPLOSIVE ATMOSPHERE.

Do not operate the instrument in the presence of flammable gases or fumes. Operation of any electrical instrument in such an environment constitutes a definite safety hazard.

KEEP AWAY FROM LIVE CIRCUITS.

Operating personnel must not remove instrument covers. Component replacement and internal adjustments must be made by qualified maintenance personnel. Do not replace components with the power cable connected. Under certain conditions, dangerous voltages may exist even with the power cable removed. To avoid injuries, always disconnect power and discharge circuits before touching them.

DO NOT SERVICE OR ADJUST ALONE.

Do not attempt internal service or adjustment unless another person, capable of rendering first aid and resuscitation, is present.

DO NOT SUBSTITUTE PARTS OR MODIFY INSTRUMENT.

Because of the danger of introducing additional hazards, do not install substitute parts or perform any unauthorized modification of the instrument. Return the instrument to a Hewlett-Packard Sales and Service Office for service and repair to ensure that safety features are maintained.

DANGEROUS PROCEDURE WARNINGS.

Warnings, such as the example below, precede potentially dangerous procedures throughout this manual. Instructions contained in the warnings must be followed.

WARNING

Dangerous voltages, capable of causing death, are present in this instrument. Use extreme caution when handling, testing, and adjusting.

SAFETY SYMBOLS

General Definitions of Safety Symbols Used on Equipment or in Manuals.



Instruction manual symbol: the product is marked with this symbol when it is necessary for the user to refer to the instruction manual in order to protect against damage to the instrument.



Indicates dangerous voltage (terminals fed from the interior by voltage exceeding 1000 volts must be so marked).



OR



Protective conductor terminal. For protection against electrical shock in case of a fault. Used with field wiring terminals to indicate the terminal which must be connected to ground before operating equipment.



Low-noise or noiseless, clean ground (earth) terminal. Used for a signal common, as well as providing protection against electrical shock in case of a fault. A terminal marked with this symbol must be connected to ground in the manner described in the installation (operating) manual, and before operating the equipment.



OR



Frame or chassis terminal. A connection to the frame (chassis) of the equipment which normally includes all exposed metal structures.



Alternating current (power line).



Direct current (power line).



Alternating or direct current (power line).



WARNING

The **WARNING** sign denotes a hazard. It calls attention to a procedure, practice, condition or the like, which, if not correctly performed, could result in injury or death to personnel.



CAUTION

The **CAUTION** sign denotes a hazard. It calls attention to an operating procedure, practice, condition or the like, which, if not correctly performed or adhered to, could result in damage to or destruction of part or all of the product.

NOTE :

The **NOTE** sign denotes important information. It calls attention to procedure, practice, condition or the like, which is essential to highlight.



SERVICE MANUAL

**MODEL 64340A
SOFTWARE ANALYZER**

REPAIR NUMBERS

This manual applies to **HP 64340A Software Analyzer** with a repair number prefix of 2426A. For further information on repair numbers refer to "Instruments Covered by This Manual" in Chapter 1.

**© COPYRIGHT HEWLETT-PACKARD COMPANY 1984
LOGIC SYSTEMS DIVISION
COLORADO SPRINGS, COLORADO, U.S.A.**

ALL RIGHTS RESERVED

Manual Part No. 64340-90901

**PRINTED: December 1984
UPDATED: May 1985**

Printing History

Each new edition of this manual incorporates all material updated since the previous edition. Manual change sheets are issued between editions, allowing you to correct or insert information in the current edition.

The part number changes only when each new edition is published. Minor corrections or additions may be made as the manual is reprinted between editions. Vertical bars in a page margin indicate the location of reprint corrections.

First Edition December 1984 64340-90901
Update 1 May 1985

Table of Contents

Chapter 1: GENERAL INFORMATION

Introduction	1-1
Manual Organization	1-1
Instruments Covered By This Manual	1-1
Software Analyzer Description	1-2
Electrical Specifications	1-2
Software Analyzer Description	1-3
Accessories Supplied	1-3
Equipment Required But Not Supplied	1-3
Manuals Supporting This Product	1-3

Chapter 2: INSTALLATION

Introduction	2-1
Initial Inspection	2-1
Installation	2-1
Procedure To Install the HP 64340A Module	2-1
Operating Environment	2-11
Storage and Shipment	2-11
Environment	2-11
Original Packaging	2-11
Other Packaging	2-11
Power Down the System Under Test	2-12
Protect Against Static Discharge	2-12
 CAUTION	2-12

Chapter 3: PERFORMANCE VERIFICATION

Introduction	3-1
Performance Verification	3-1
Procedure To Run Main Test Performance Verification	3-1
Standard Option Test	3-2
Theory and Troubleshooting	3-3
Software Analyzer Subsystem Description	3-3
Theory of Operation	3-3
General Block Description of the HP 64340A Hardware	3-3
CPU Board Block Theory	3-4
Acquisition Board Block Theory	3-6
Control Board Block Theory	3-8
Troubleshooting	3-11
Troubleshooting Hints	3-12
Procedure To Run the HP 64340A Software Analyzer PV	3-12
Procedure To Run the External IMB Performance Verification Test	3-12
Performance Verification Test Displays	3-16

TABLE OF CONTENTS (Cont'd)

Chapter 4: ADJUSTMENTS

Introduction	4-1
Safety Requirements	4-1
Equipment Required	4-1
Calibration Procedure	4-1

Chapter 5: REPLACEABLE PARTS

Introduction	5-1
Replaceable Parts	5-1
Abbreviations	5-1

Chapter 6: MANUAL CHANGES

Introduction	6-1
------------------------	-----

LIST OF ILLUSTRATIONS

Chapter 1: GENERAL INFORMATION

1-1. Model 64340A Software Analyzer	1-0
---	-----

Chapter 2: INSTALLATION

2-1. Cardcage Cover Removal	2-9
2-2. Installation of the Inter-connect Cables to the Acquisition Board	2-10
2-3. Installing the 64340A Module in the 64100A Logic Development Station	2-10

LIST OF ILLUSTRATIONS (Cont'd)

Chapter 3. PERFORMANCE VERIFICATION AND TROUBLESHOOTING

3-1. CPU Board Block Diagram	3-5
3-2. Acquisition Board Block Diagram	3-7
3-3. Control Board Block Diagram	3-10
3-4. Software Analyzer Performance Verification (main test)	3-11
3-5. Software Analyzer Performance Verification (first level)	3-16
3-6. Software Analyzer CPU Board Test (second level)	3-17
3-7. CPU Board - System Interface Tests (third level)	3-17
3-8. CPU Board - CPU Memory Tests (fourth level)	3-18
3-9. CPU Board - CPU Tests (third level)	3-18
3-10. CPU Board - CPU Memory Tests (third level)	3-19
3-11. CPU Board - Acquisition Memory Tests (third level)	3-19
3-12. Control Board - Control Board Tests (second level)	3-20
3-13. Control Board - IMB Interface Tests (third level)	3-20
3-14. Control Board - External Stimulus Test (fourth level)	3-21
3-15. CPU Board Missing Message	3-21
3-16. Incomplete Set of Cards Message	3-22
3-17. Emulation Analysis Screen - Test Can Be Executed	3-22
3-18. Emulation Analysis Screen - No Control Board	3-23
3-19. Emulation Analysis Screen - No ACQ Board	3-23
3-20. Emulation Analysis Screen - No Control and ACQ Boards	3-24
3-21. CPU Fails Handshake	3-24
3-22. File Containing the 68000 Stimulus Code Missing	3-25

Chapter 4. ADJUSTMENTS

4-1. Calibration Timing Relationships	4-3
---	-----

Chapter 5. REPLACEABLE PARTS

5-1. Reference Designator Breakdown	5-3
---	-----

LIST OF TABLES

Chapter 1. GENERAL INFORMATION

1-1. HP 64340A Software Analyzer Power Consumption	1-2
--	-----

Chapter 2. INSTALLATION

2-1. HP 64340A (68000) Configurations, Current Usages, and Cable Options	2-2
2-2. HP 64340A (80186) Configurations, Current Usages, and Cable Options	2-6

Chapter 3. PERFORMANCE VERIFICATION AND TROUBLESHOOTING

3-1. Bluestripe Troubleshooting Flowchart	3-14
---	------

Chapter 5. REPLACEABLE PARTS

5-1. Replaceable Parts	5-1
5-2. Reference Designators and Abbreviations	5-2

NOTES

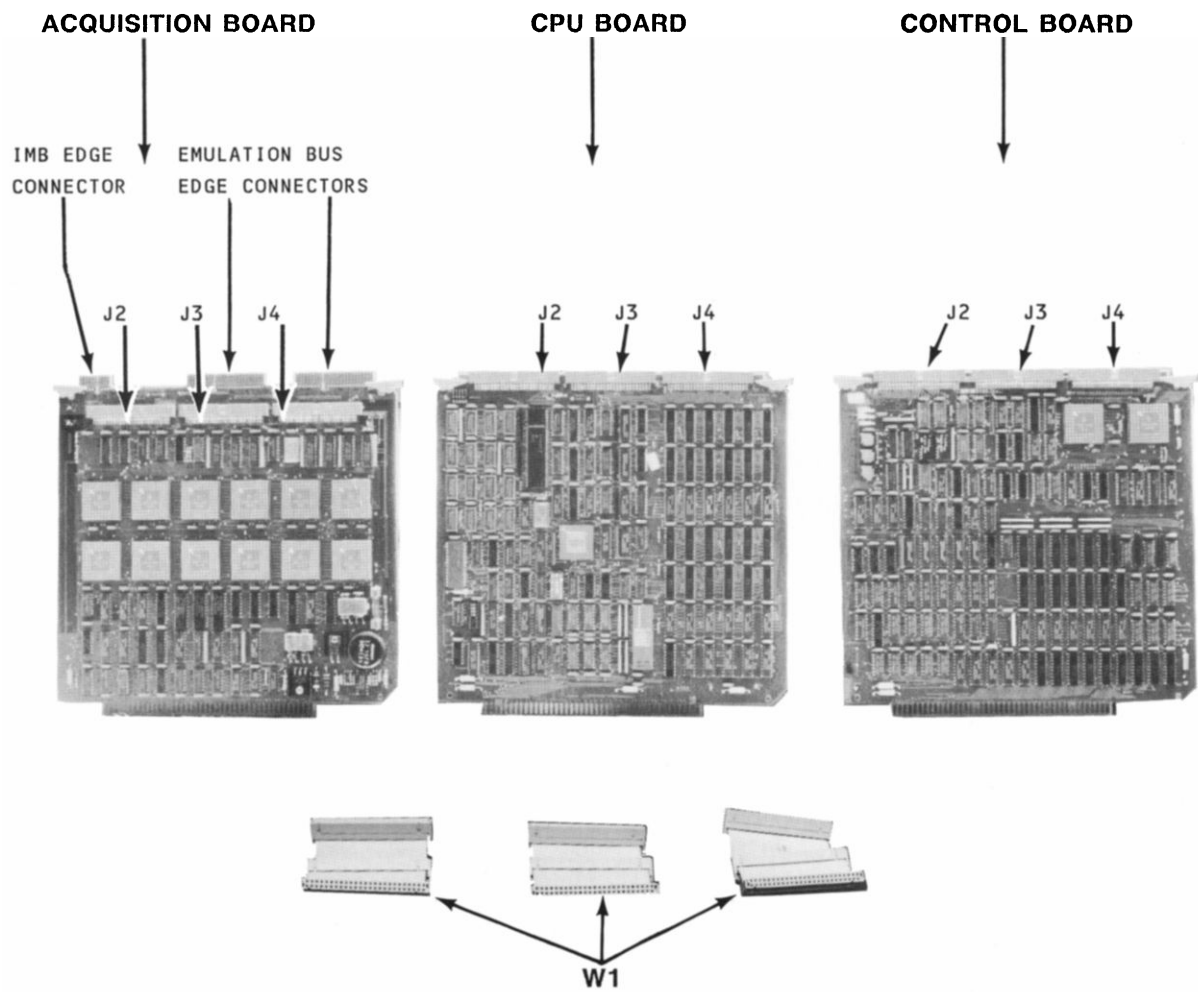

Figure 1-1. Model 64340A Software Analyzer

Chapter 1

GENERAL INFORMATION

INTRODUCTION

This manual contains information concerning the installation, maintenance and troubleshooting of the Model 64340A Software Analyzer to the "Bluestripe" board level. In the event a board does fail, it can be shipped back to the factory and replaced with a replacement board at a lesser cost than buying a new board. Refer to the nearest Hewlett-Packard Sales/Service Office for more information on the Bluestripe program.

MANUAL ORGANIZATION

This is a Bluestripe service manual and is organized in six chapters. These are:

Chapter 1 contains general information on the Model 64340A, including electrical specifications and equipment requirements.

Chapter 2 explains how to install the Model 64340A in the HP 64100A Logic Development Station, and also includes information on environmental limits of operation and packing instructions.

Chapter 3 contains performance verification procedures for verifying operation of the HP 64340A Software Analyzer. This chapter also contains block level theory and troubleshooting procedures.

Chapter 4 contains information on adjustments the the Model 64340A Software Analyzer requires periodically.

Chapter 5 lists all parts of the Model 64340A that may be directly replaceable.

Chapter 6 contains information on the product serial prefix number(s) this manual applies to, and how to adapt this manual to instruments which the contents do not directly apply.

INSTRUMENTS COVERED BY THIS MANUAL

Printed on the printed circuit board is the repair number. The repair number is in the form: 0000A00000. It is in two parts; the first four digits and the letter are the prefix, and the last five are the suffix. The prefix is the same for all identical instruments. The suffix is assigned sequentially and is different for each instrument. The contents of this manual apply to instruments with the repair number prefix(es) listed on the title page.

An instrument manufactured after the printing of this manual may have a repair number prefix that is not listed on the title page. This unlisted repair number prefix indicates that the instrument is different from those described in this manual. The manual for this newer instrument is accompanied by a Manual Change supplement.

For information concerning a repair number prefix that is not listed on the title page or in the Manual Changes supplement, contact your nearest Hewlett-Packard Office.

ELECTRICAL SPECIFICATIONS

Table 1-1. HP 64340A Software Analyzer Power Consumption

CPU POWER	TYPICAL	TYPICAL +20%
+5V POWER	24.38 W	29.26 W
-5.2V POWER	1.26 W	1.51 W
-3.25V POWER	1.33 W	1.55 W
TOTAL POWER	26.97 W	32.32 W

CNTL POWER	TYPICAL	TYPICAL +20%
+5V POWER	17.52 W	21.02 W
-5.2V POWER	4.25 W	5.10 W
TOTAL POWER	21.77 W	26.12 W

ACQ POWER	TYPICAL	TYPICAL +20%
+5V POWER	22.05 W	26.46 W
-5.2V POWER	.36 W	.43 W
TOTAL POWER	22.41 W	26.89 W

TOTAL POWER CONSUMPTION OF ALL THREE BOARDS	TYPICAL	TYPICAL +20%
+5V POWER	61.95 W	76.74 W
-5.2V POWER	5.87 W	7.64 W
TOTAL POWER	71.15 W	85.33 W

SOFTWARE ANALYZER DESCRIPTION

The HP 64340A Software Analyzer is an automated software measurement system designed to work with the HP 64100A Logic Development System to improve the productivity of the software engineer in the areas of debugging, testing, and designing. It is a three board set, and has the following capabilities:

Program/data flow measurements. Provide for overview of program control flow, data flow, program control flow/data flow interactions, and data modifications.

Program performance/testing measurements. Provide for real-time count and time metrics on program statement and module execution.

View and modify variables.

Measurement control. Commands for conditional execution of the measurements using comparisons between variables and values, or program execution and line numbers.

ACCESSORIES SUPPLIED

There are no accessories supplied with the basic HP 64340A Module (3 board set). When ordering other options to be used with the HP 64340A Module (such as State/Timing), special cable configurations will be required. Tables 2-1 (68000/10) and 2-2 (80186/88) list configurations, current usages, and cable options.

There are specific HP Software Part Numbers that are required to run the HP 64340A Module; these part numbers for the various supported emulators are as follows:

MODEL	EMULATOR	SOFTWARE PART NO.
64242A	68000	64341BA
64249A	68010	64341DA
64224A	80186	64341EA
64225A	80188	64341FA

NOTE

64224A 80186 Emulators must have a serial prefix of 25XXA or greater. If your emulator has a serial prefix number less than 25XXA (example : 24XXA), call your nearest Hewlett-Packard Sales/Service Office about purchasing an upgrade kit.

EQUIPMENT REQUIRED BUT NOT SUPPLIED

(for calibration).....1726A Oscilloscope (275 MHz)

(for calibration).....10017A Scope probe (Qty 2)

(for calibration).....64110-66503 Extender board (Qty 3)

(for calibration).....Adjustment Tool (insulated flathead type)

MANUALS SUPPORTING THIS PRODUCT

Service Manual for 64340A

Operating Manual - 64341BA/DA for 68000/10

Operating Manual - 64341EA/FA for 80186/88



Chapter 2

INSTALLATION

INTRODUCTION

This chapter contains information to install the HP 64340A Software Analyzer in the 64000 System. Information concerning initial inspection, damage claims, environmental considerations, storage and shipment is also included.

INITIAL INSPECTION

Inspect the shipping container for damage. If the shipping container or cushioning material is damaged, it should be kept until the contents have been checked for completeness and the HP 64340A has been checked mechanically and electrically. If the contents are incomplete, if there is mechanical damage or defect, or if the HP 64340A does not pass Performance Verification, notify the nearest Hewlett-Packard Office. If the shipping container or cushioning material is damaged, notify the carrier as well as the Hewlett-Packard Office. Keep the shipping materials for carrier's inspection. The HP Office will arrange for repair or replacement at HP option without waiting for claim settlement.

INSTALLATION

All three boards of the HP 64340A Software Analyzer are installed into the 64100A Logic Development Station. They must be placed into the System cardcage as follows (from low to high card slot numbers): The CPU board must be first, the Control board second, and the Acquisition board third. See figure 2-3. The lowest numbered card slot is closest to the front of the development station.

Procedure To Install the HP 64340A Module:

- a) Power down the development station.
- b) Remove the four screws that secure the cardcage cover to the top of the HP 64100A Logic Development Station. See figure 2-1.
- c) Install the three inter-connect cables (W1) onto J2, J3, and J4 of the Acquisition board (A3). See figure 2-2.
- d) Install the CPU board in first. Note the position of the CPU board to the other options (State/Timing, Analysis). See tables 2-1 and 2-2.
- e) Install the other two boards into the development station cardcage. The position of the HP 64340A three board set in the cardcage should always be: CPU board first, the Control board second, and the Acquisition board third. See figure 2-3.
- f) Connect the three inter-connect cables that were attached to the Acquisition board from "step c" to the HP 64340A Control and CPU boards. See figure 2-3.

Table 2-1. HP 64340A (68000/10) Configurations, Current Usage, and Cable Options

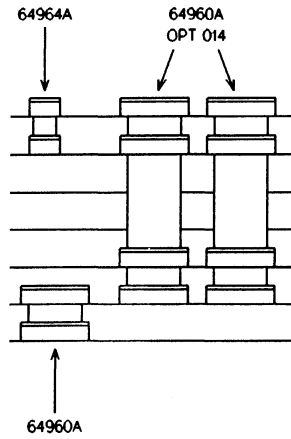

		(+5 V)
SLOT 9	64302A ANL	3.70 A
8	64340A ACQ	5.00 A
7	64340A CNTL	5.00 A
6	64340A CPU	5.00 A
5	64242A/64249A EC	6.10 A
4	64155A WIDE-ADDR MC	3.80 A
3	64161A 128K BYTE EM	1.60 A
TOTAL CURRENT		30.20 A

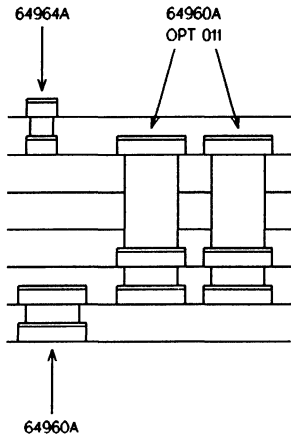

		(+5 V)
SLOT 9	64303A IMB	1.80 A
8	64340A ACQ	5.00 A
7	64340A CNTL	5.00 A
6	64340A CPU	5.00 A
5	64242A/64249A EC	6.10 A
4	64155A WIDE-ADDR MC	3.80 A
3	64161A 128K BYTE EM	1.60 A
TOTAL CURRENT		28.30 A

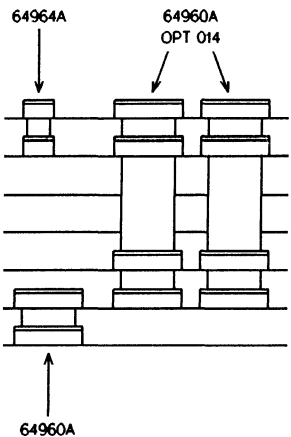

		(+5 V)
SLOT 9	64310A ANL	5.80 A
8	64340A ACQ	5.00 A
7	64340A CNTL	5.00 A
6	64340A CPU	5.00 A
5	64242A/64249A EC	6.10 A
4	64155A WIDE-ADDR MC	3.80 A
3	64161A 128K BYTE EM	1.60 A
TOTAL CURRENT		32.30 A

Table 2-1. HP 64340A (68000/10) Configurations, Current Usage, and Cable Options

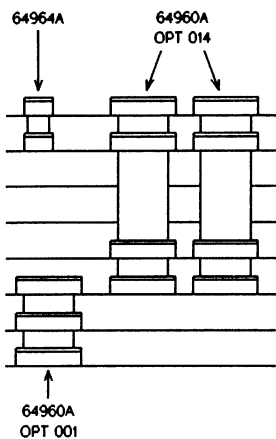

			(+5 V)
SLOT 9	64310A	ANL	5.80 A
8	64340A	ACQ	5.00 A
7	64340A	CNTL	5.00 A
6	64340A	CPU	5.00 A
5	64242A/64249A	EC	6.10 A
4	64155A	WIDE-ADDR MC	3.80 A
3	64161A	128K BYTE EM	1.60 A
2	64161A	128K BYTE EM	1.60 A
TOTAL CURRENT			33.90 A

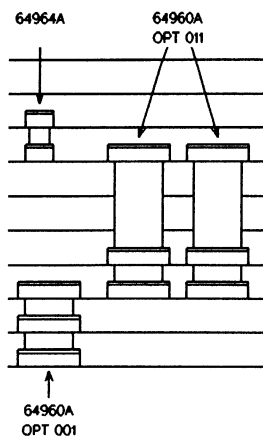

			(+5 V)
SLOT 9	OPT 011	20 CH ACQ	
8	OPT 011	40 CH ACQ	
7	64620S	STATE CNTL	10.40 A
6	64340A	ACQ	5.00 A
5	64340A	CNTL	5.00 A
4	64340A	CPU	5.00 A
3	64242A/64249A	EC	6.10 A
2	64155A	WIDE-ADDR MC	3.80 A
1	64161A	128K BYTE EM	1.60 A
0	64161A	128K BYTE EM	1.60 A
TOTAL CURRENT			38.50 A

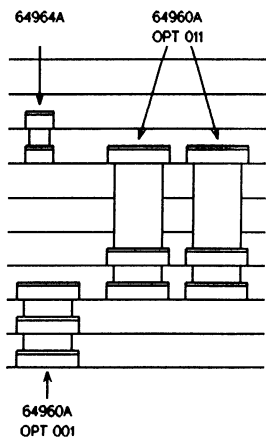

			(+5 V)
SLOT 9	OPT 012	40 CH ACQ	
8	OPT 012	40 CH ACQ	
7	64620S	STATE CNTL	12.20 A
6	64340A	ACQ	5.00 A
5	64340A	CNTL	5.00 A
4	64340A	CPU	5.00 A
3	64242A/64249A	EC	6.10 A
2	64155A	WIDE-ADDR MC	3.80 A
1	64161A	128K BYTE EM	1.60 A
0	64161A	128K BYTE EM	1.60 A
TOTAL CURRENT			40.30 A

Table 2-1. HP 64340A (68000/10) Configurations, Current Usage, and Cable Options

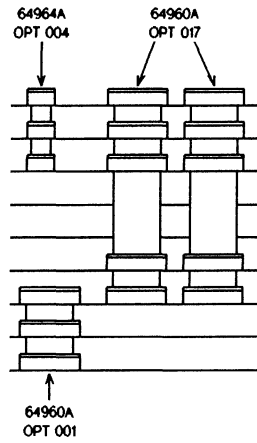

			(+5 V)
SLOT 9	64302A	ANL	3.70 A
8	64310A	ANL	5.80 A
7	64340A	ACO	5.00 A
6	64340A	CNTL	5.00 A
5	64340A	CPU	5.00 A
4	64242A/64249A	EC	6.10 A
3	64155A	WIDE-ADDR MC	3.80 A
2	64161A	128K BYTE EM	1.60 A
1	64161A	128K BYTE EM	1.60 A
TOTAL CURRENT			37.60 A

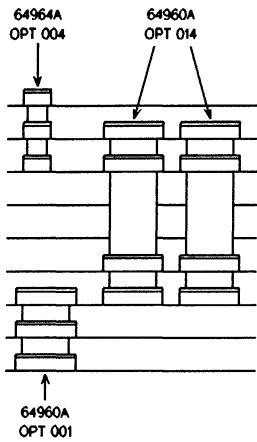

			(+5 V)
SLOT 9	64303A	IMB	1.80 A
8	64310A	ANL	5.80 A
7	64340A	ACO	5.00 A
6	64340A	CNTL	5.00 A
5	64340A	CPU	5.00 A
4	64242A/64249A	EC	6.10 A
3	64155A	WIDE-ADDR MC	3.80 A
2	64161A	128K BYTE EM	1.60 A
1	64161A	128K BYTE EM	1.60 A
TOTAL CURRENT			35.70 A

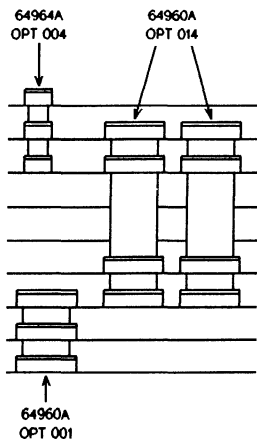

			(+5 V)
SLOT 9	64303A	IMB	1.80 A
8	64302A	ANL	3.70 A
7	64340A	ACO	5.00 A
6	64340A	CNTL	5.00 A
5	64340A	CPU	5.00 A
4	64242A/64249A	EC	6.10 A
3	64155A	WIDE-ADDR MC	3.80 A
2	64161A	128K BYTE EM	1.60 A
1	64161A	128K BYTE EM	1.60 A
TOTAL CURRENT			33.60 A

Table 2-1. HP 64340A (68000/10) Configurations, Current Usage, and Cable Options

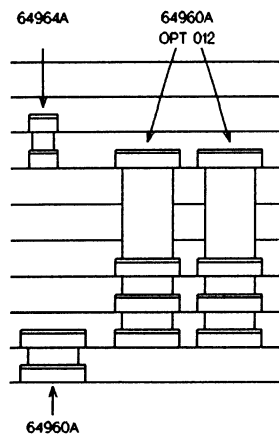

		(+5 V)
SLOT 9	OPT 011 20 CH ACQ	
8	OPT 011 40 CH ACQ	
7	64620S STATE CNTL	10.40 A
6	64340A ACQ	5.00 A
5	64340A CNTL	5.00 A
4	64340A CPU	5.00 A
3	64304A EBPP	1.50 A
2	64242A/64249A EC	6.10 A
1	64155A WIDE-ADDR MC	3.80 A
0	64161A 128K BYTE EM	1.60 A
TOTAL CURRENT		38.40 A

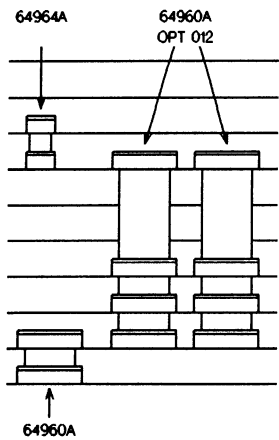

		(+5 V)
SLOT 9	OPT 012 40 CH ACQ	
8	OPT 012 40 CH ACQ	
7	64620S STATE CNTL	12.20 A
6	64340A ACQ	5.00 A
5	64340A CNTL	5.00 A
4	64340A CPU	5.00 A
3	64304A EBPP	1.50 A
2	64242A/64249A EC	6.10 A
1	64155A WIDE-ADDR MC	3.80 A
0	64161A 128K BYTE EM	1.60 A
TOTAL CURRENT		40.20 A

Table 2-2. HP 64340A (80186/88) Configurations, Current Usage, and Cable Options

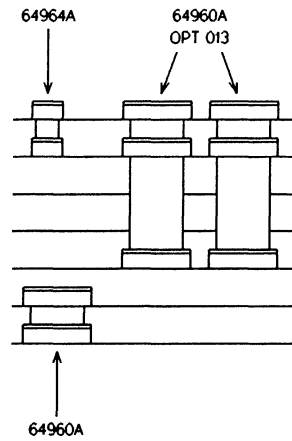

			(+5 V)
SLOT 9	64302A	ANL	3.70 A
8	64340A	ACQ	5.00 A
7	64340A	CNTL	5.00 A
6	64340A	CPU	5.00 A
5	64224A/64225A	EC	6.20 A
4	64155A	WIDE-ADDR MC	3.80 A
3	64161A	128K BYTE EM	1.60 A
TOTAL CURRENT			30.30 A

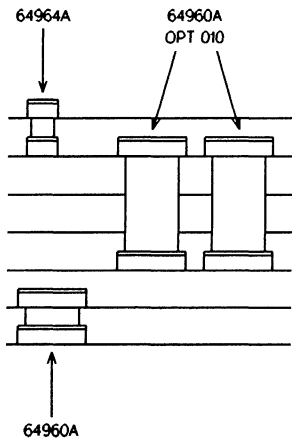

			(+5 V)
SLOT 9	64303A	IMB	1.80 A
8	64340A	ACQ	5.00 A
7	64340A	CNTL	5.00 A
6	64340A	CPU	5.00 A
5	64224A/64225A	EC	6.20 A
4	64155A	WIDE-ADDR MC	3.80 A
3	64161A	128K BYTE EM	1.60 A
TOTAL CURRENT			28.40 A

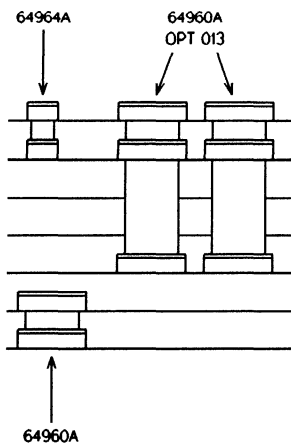

			(+5 V)
SLOT 9	64310A	ANL	5.80 A
8	64340A	ACQ	5.00 A
7	64340A	CNTL	5.00 A
6	64340A	CPU	5.00 A
5	64224A/64225A	EC	6.20 A
4	64155A	WIDE-ADDR MC	3.80 A
3	64161A	128K BYTE EM	1.60 A
TOTAL CURRENT			32.40 A

Table 2-2. HP 64340A (80186/88) Configurations, Current Usage, and Cable Options

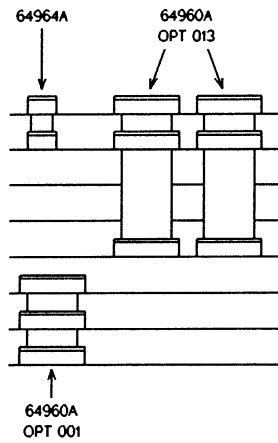

		(+5 V)
SLOT 9	64310A ANL	5.80 A
8	64340A ACQ	5.00 A
7	64340A CNTL	5.00 A
6	64340A CPU	5.00 A
5	64224A/64225A EC	6.20 A
4	64155A WIDE-ADDR MC	3.80 A
3	64161A 128K BYTE EM	1.60 A
2	64161A 128K BYTE EM	1.60 A
TOTAL CURRENT		34.00 A

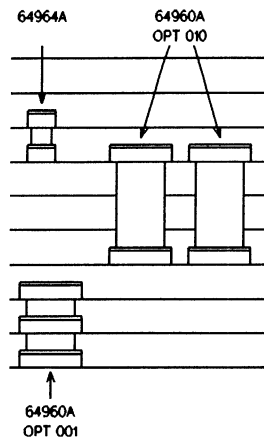

		(+5 V)
SLOT 9	OPT 011 20 CH ACQ	
8	OPT 011 40 CH ACQ	
7	64620S STATE CNTL	10.40 A
6	64340A ACQ	5.00 A
5	64340A CNTL	5.00 A
4	64340A CPU	5.00 A
3	64224A/64225A EC	6.20 A
2	64155A WIDE-ADDR MC	3.80 A
1	64161A 128K BYTE EM	1.60 A
0	64161A 128K BYTE EM	1.60 A
TOTAL CURRENT		38.60 A

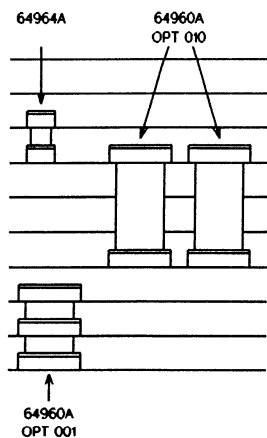

		(+5 V)
SLOT 9	OPT 012 40 CH ACQ	
8	OPT 012 40 CH ACQ	
7	64620S STATE CNTL	12.20 A
6	64340A ACQ	5.00 A
5	64340A CNTL	5.00 A
4	64340A CPU	5.00 A
3	64224A/64225A EC	6.20 A
2	64155A WIDE-ADDR MC	3.80 A
1	64161A 128K BYTE EM	1.60 A
0	64161A 128K BYTE EM	1.60 A
TOTAL CURRENT		40.40 A

Table 2-2. HP 64340A (80186/88) Configurations, Current Usage, and Cable Options

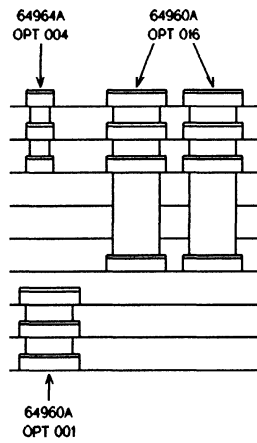

			(+5 V)
SLOT 9	64302A	ANL	3.70 A
8	64310A	ANL	5.80 A
7	64340A	ACQ	5.00 A
6	64340A	CNTL	5.00 A
5	64340A	CPU	5.00 A
4	64224A/64225A	EC	6.20 A
3	64155A	WIDE-ADDR MC	3.80 A
2	64161A	128K BYTE EM	1.60 A
1	64161A	128K BYTE EM	1.60 A
TOTAL CURRENT			37.70 A

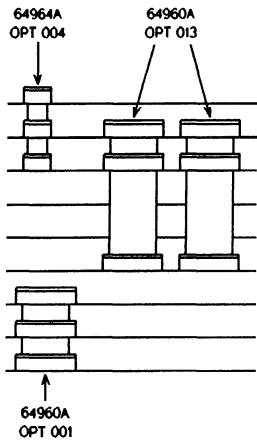

			(+5 V)
SLOT 9	64303A	IMB	1.80 A
8	64310A	ANL	5.80 A
7	64340A	ACQ	5.00 A
6	64340A	CNTL	5.00 A
5	64340A	CPU	5.00 A
4	64224A/64225A	EC	6.20 A
3	64155A	WIDE-ADDR MC	3.80 A
2	64161A	128K BYTE EM	1.60 A
1	64161A	128K BYTE EM	1.60 A
TOTAL CURRENT			35.80 A

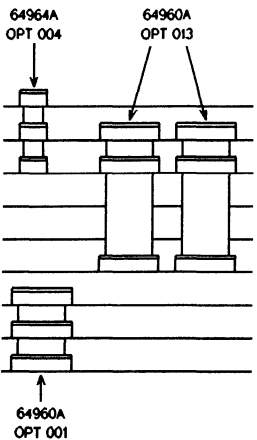

			(+5 V)
SLOT 9	64303A	IMB	1.80 A
8	64302A	ANL	3.70 A
7	64340A	ACQ	5.00 A
6	64340A	CNTL	5.00 A
5	64340A	CPU	5.00 A
4	64224A/64225A	EC	6.20 A
3	64155A	WIDE-ADDR MC	3.80 A
2	64161A	128K BYTE EM	1.60 A
1	64161A	128K BYTE EM	1.60 A
TOTAL CURRENT			33.70 A

Table 2-2. HP 64340A (80186) Configurations, Current Usage, and Cable Options

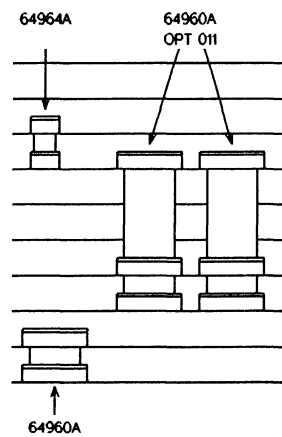

		(+5 V)
SLOT 9	OPT 011 20 CH ACQ	
8	OPT 011 40 CH ACQ	
7	64620S STATE CNTL	10.40 A
6	64340A ACQ	5.00 A
5	64340A CNTL	5.00 A
4	64340A CPU	5.00 A
3	64304A EBPP	1.50 A
2	64224A/64225A EC	6.20 A
1	64155A WIDE-ADDR MC	3.80 A
0	64161A 128K BYTE EM	1.60 A
TOTAL CURRENT		38.50 A

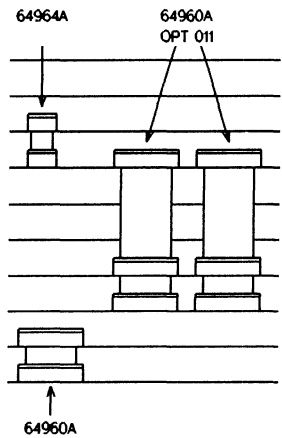

		(+5 V)
SLOT 9	OPT 012 40 CH ACQ	
8	OPT 012 40 CH ACQ	
7	64620S STATE CNTL	12.20 A
6	64340A ACQ	5.00 A
5	64340A CNTL	5.00 A
4	64340A CPU	5.00 A
3	64304A EBPP	1.50 A
2	64224A/64225A EC	6.20 A
1	64155A WIDE-ADDR MC	3.80 A
0	64161A 128K BYTE EM	1.60 A
TOTAL CURRENT		40.30 A

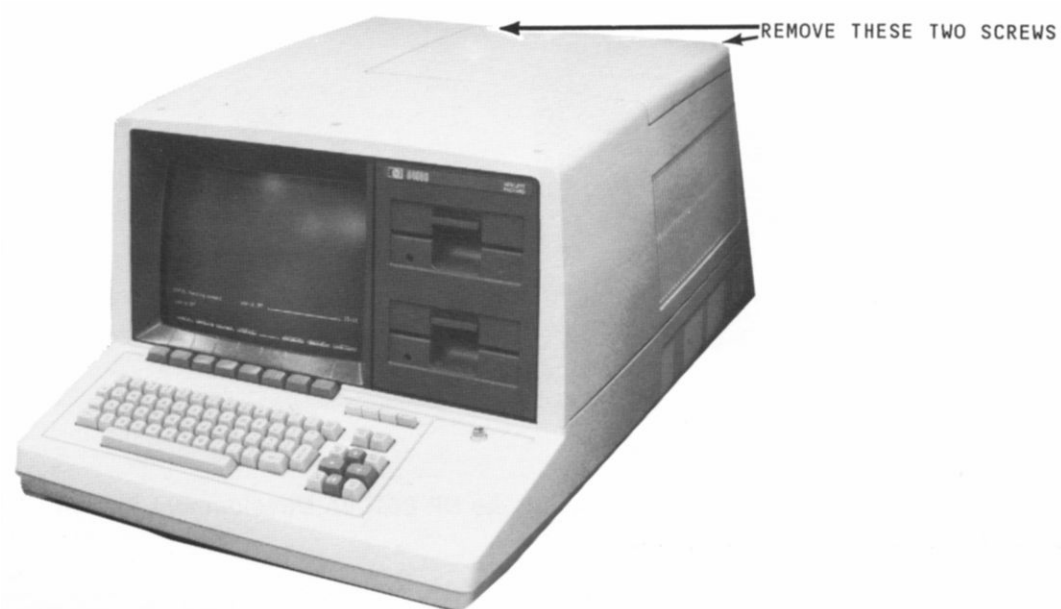

Figure 2-1. HP 64100A Cardcage Cover Removal

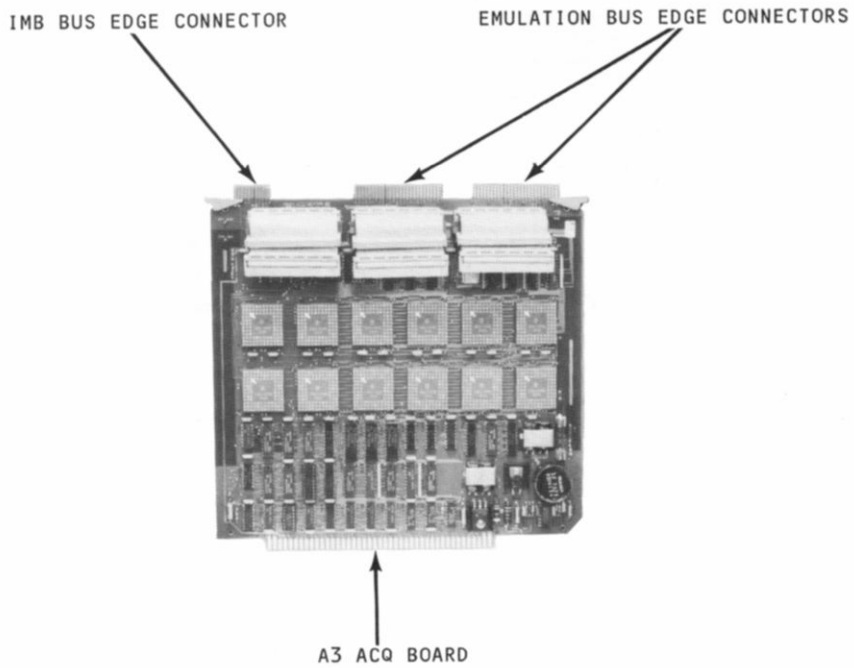

Figure 2-2. Installation of the Inter-connect Cables to the Acquisition board

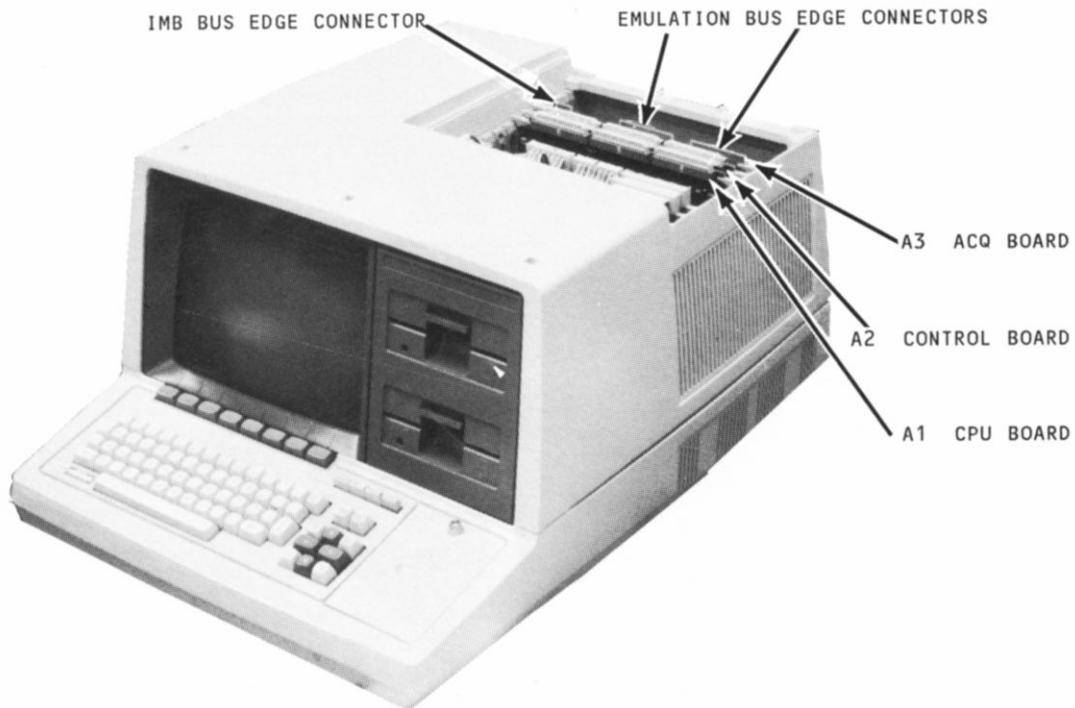

Figure 2-3. Installing the Model 64340A into the HP 64100A Development Station

OPERATING ENVIRONMENT

The Model 64340A may be operated in environments within the following limits:

Temperature.....0 to +40 C
Humidity5 to 80% relative humidity at +40 C
Altitude 4 600 meters (15 000 ft)

The HP 64340A Software Analyzer should be protected from temperature extremes which cause condensation.

STORAGE AND SHIPMENT

Environment

The Model 64340A may be stored or shipped in environments within the following limits:

Temperature..... -40 to +75 C
Humidity 5 to 80% relative humidity
Altitude15 000 meters (50 000 ft)

Original Packaging

Containers and packing materials identical to those used in factory packaging are available through Hewlett-Packard Offices.

Other Packaging

The following general instructions should be used for re-packing with commercially available materials:

- a. Wrap each of the HP 64340A Software Analyzer boards in heavy paper or plastic.
- b. Use a strong shipping container. A double-wall carton made of 350-pound test material is adequate.
- c. Use a layer of shock-absorbing material 70 to 100 mm (3 to 4 inch) thick around all sides of the HP 64340A Module to provide firm cushioning and prevent movement inside the container.
- d. Seal the shipping container securely.
- e. Mark the shipping container FRAGILE to insure careful handling.
- f. In any correspondence, refer to the instrument by model number and full serial number.



The following precautions should be taken while using Hewlett-Packard Software Analyzer. Damage to the circuitry may result if these precautions are not observed.

POWER DOWN THE SYSTEM UNDER TEST

Turn off power to development station before installing the HP 64340A Module into the cardcage. This will avoid circuit damage that may result from voltage transients.

PROTECT AGAINST STATIC DISCHARGE

The three boards of the HP 64340A contain components which are susceptible to damage from static discharge. To avoid damage, take these precautions before handling the HP 64340A Module. Handle boards from the sides ONLY! Never touch the bottom of a HP 64340A board!

Chapter 3

PERFORMANCE VERIFICATION

INTRODUCTION

This chapter describes performance verification (PV) procedures for testing and troubleshooting the HP 64340A Software Analyzer. Performance Verification displays are included with each test description for convenience.

PERFORMANCE VERIFICATION

Performance verification for the HP 64340A Module is a subset of the system Option Test Performance Verification. The system level PV tests all option modules that are located in the development station cardcage.

Procedure To Run Main Test Performance Verification:

To verify that the HP 64340A passes performance verification, perform the following:

- a) Press the [---ETC---] softkey until the [opt_test] softkey appears.
- b) Press the [opt_test] softkey, followed by the RETURN key.
- c) Select one of the three HP 64340A Software Analyzer boards, and type in its card slot position, followed by the RETURN key. NOTE: It makes no difference which board is selected, i.e., the same test will be executed no matter which of the three boards is selected.
- d) If IMB stimulus is present in the cardcage, the screen will ask for the IMB stimulus slot number. Type in its slot position, followed by the RETURN key.

NOTE

By selecting the HP 64340A CPU board as the IMB stimulus, the IMB tests will be bypassed.

- e) Press the [cycle] softkey to test all three HP 64340A Software Analyzer boards.
- f) Press the [end] softkey to stop the test and return to the [opt_test] screen.
- g) Press the [end] softkey again to leave performance verification.

If any of the three tests fail, refer to the Troubleshooting Flowchart, table 3-1 in this chapter.

STANDARD OPTION TEST

Option_test softkeys are used to command the execution of performance verification tests in a desired sequence. Pressing a particular softkey will produce the following results:

[end]) stops the execution of any test and causes the exit of the present module PV testing. The result is a menu of card slot options awaiting a selection for Performance Verification testing.
[cycle]) causes all tests on the screen to be executed in sequence. All subtests below a listed test are executed.
[next_test]) causes the enhanced line to move to the next test displayed on the screen.
[start]) causes the displayed test to be executed. The test will continue to execute until some other displayed softkey is pressed or the [start] softkey is pressed again.
[disp_test]) will display a list of tests or a single test associated with the test highlighted by inverse video.
[exit_test]) will stop a test and exit to the previous display.
[print]) will print the current display to a printer attached to the 64000 station.

THEORY AND TROUBLESHOOTING

Read the Safety Summary at the front of this manual before attempting to service the HP 64340A Software Analyzer.

SOFTWARE ANALYZER SUBSYSTEM DESCRIPTION

The Software Analyzer Subsystem consists of a CPU board, Control board, and the Acquisition board. The system will not operate alone. It must be installed into a HP 64100A and connected to an Emulation Module, or a State/Timing Module.

THEORY OF OPERATION

The block theory will be broken up into four sections. These are:

- 1) Overall Block Theory
- 2) CPU Board Block Theory
- 3) Control Board Block Theory
- 4) Acquisition Board Block Theory

General Block Description of the HP 64340A Hardware

The HP 64340A hardware is comprised of three option boards; the "CPU board" which is the 64340-66501 board, the "Control board" which is 64340-66502 board, the "Acquisition board" which is the 64340-66503 board. These three boards are interconnected by three ribbon cables. The J2, J3, and J4 edge connectors on top of each of these three boards are connected together by their respective ribbon cable (i.e. J2 on the CPU board, J2 on the Control board, and J2 on the Acquisition board are connected together).

The ID generated from the CPU board is 0104 HEX. This ID is in the range of IDs that have Inter Modular Bus (IMB) capability. The IMB cable connector tab is located on top of the Acquisition board. The IMB drive and receive circuitry is on the Control board. The CPU board only appears to have IMB capability since it communicates with the host processor, the Control board does all the talking over the IMB.

The ID generated from the Control board is 1008 HEX, and the ID generated from the Acquisition board is 1009 HEX. The Control and Acquisition boards have no direct communication with the host processor except for ID generation and LPOP reception by the Control board. The Control and Acquisition boards are controlled by the HP 64340A CPU board.

The order in which the three HP 64340A boards are placed into the 64000 cardcage is important. The Acquisition board has the IMB edge connector located on the upper-left hand corner. It is connected by this IMB edge connector to other Analysis boards which may occupy higher card slot positions. See tables 2-1 and 2-2. The Acquisition board should be placed one card slot higher than the Control board. The Control board should be placed one card slot higher than the CPU board. So, from the least significant card slot number, the order of boards must be: 1) CPU board, 2) Control board, 3) Acquisition board. This does not mean that the HP 64340A CPU board has to be placed in card slot number one. It means it must be placed in the least significant card slot number available depending on which Emulation or other options boards are used. See tables 2-1 and 2-2.

General Block Description of the HP 64340A Hardware (Cont'd)

External Analyzer boards such as the 64300A, 64302A, and 64310A need to be positioned in a greater card slot position than the HP 64340A Software Analyzer subsystem.

Up to two Emulation Analyzers, in addition to the HP 64340A Software Analyzer can be connected to the emulation bus (because of loading restrictions).

The left most of the inter-board cables (connects to J2 on all three HP 64340A boards) transfers buffered versions of the 68000 address and data busses from the HP 64340A CPU board to the other two boards. The center inter-board cable (connects J3 on all three boards) connects five ECL signals. These signals come from IMB edge connector on the Acquisition board and go to the Control board where the IMB interface logic resides. This center inter-board cable also distributes clocks generated by the Control board to the other two boards along with dedicated function signals. The right most inter-board cable connects address and status busses between all three HP 64340A boards.

CPU Board Block Theory

The CPU used on the HP 64340A CPU board is a MC68000R8. This is a 8 Mhz 68000 microprocessor. The clock source is an 8 Mhz TTL oscillator. There are two possible interrupt sources: Delta time, and Host Processor Interrupt. The interrupts are driven by open collector drivers so that emulators can be plugged into the HP 64340A for code development.

The 68000 address bus which is connected to all three HP 64340A boards, is buffered to prevent drive and propagation delay problems. The address bus output enable is controlled by the bus arbitrator with the exception of the upper four bits. When the Host Processor is using the HP 64340A system bus, the address lines are pulled up on the inputs to the buffers forcing the Host Processor to access only the DRAM. The Host Processor is not allowed access to any other hardware at any time.

The 68000 Bus Arbitrator control unit is implemented with a finite state machine. All asynchronous signal inputs are synchronized by the state machine. State changes occur on the next rising edge after the signal has been internally synchronized and recognized.

The DRAM controller chip controls address multiplexing, refresh processing, and RAS/CAS generation. The DRAMs have a 9 bit multiplexed address bus and separate I/O. RAS and CAS are used to clock the row column address into the DRAMs. The DRAMs have a cycle time of 260 nano seconds and an access time of 150 nano seconds.

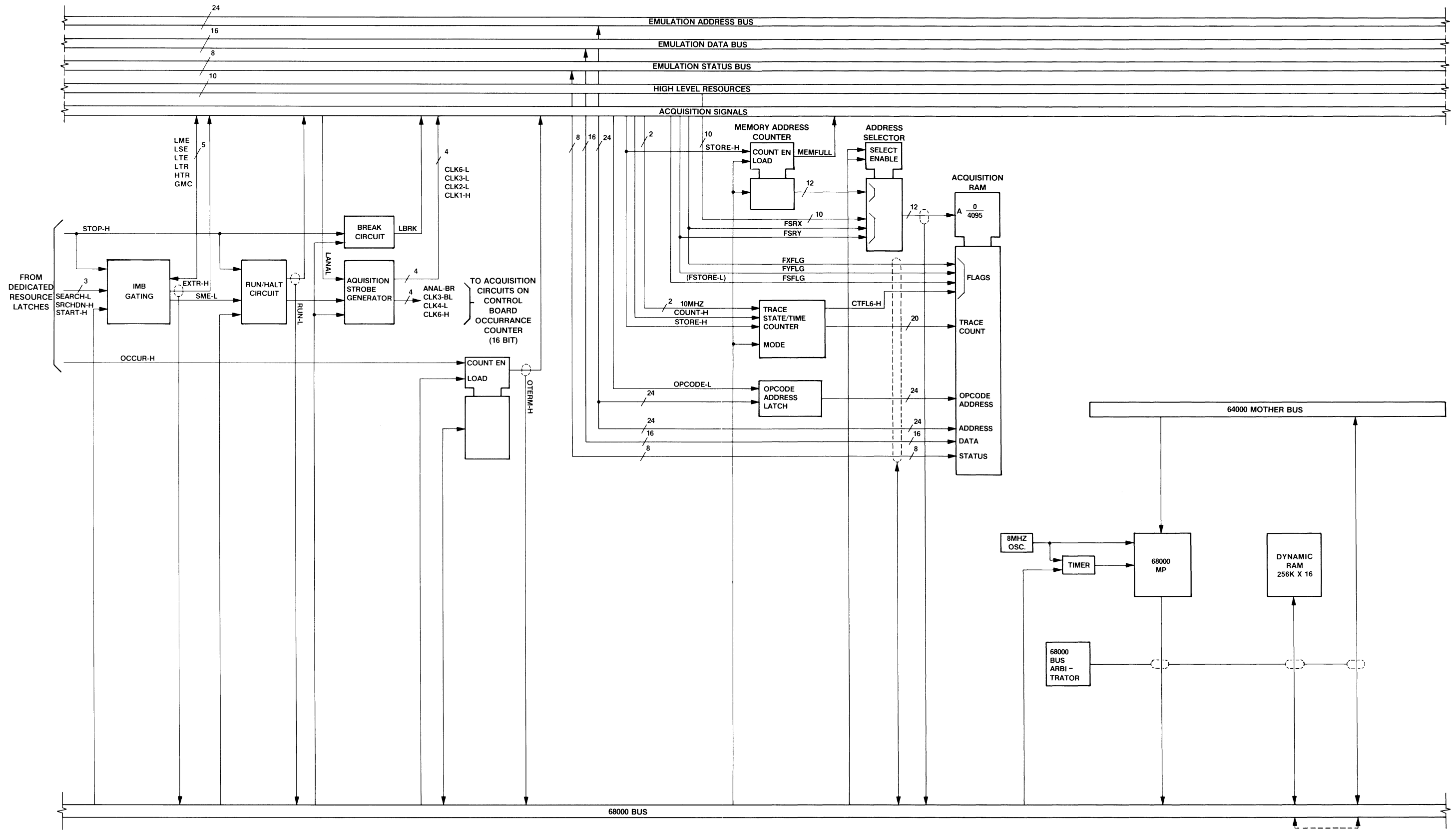

Figure 3-1.
CPU Board Block Diagram

Acquisition Board Block Theory

This section will address the Acquisition Block Theory by briefly describing the overall block diagram of the HP 64340A Acquisition board.

The AME chip compares binary patterns and checks the range it operates within in a 1, 0, X (don't care) fashion on 32 bits of input data. It also has two sets of outputs to provide the same range information on the upper and lower 16 bits of input data.

The Strobe Generator combines two signals to generate the strobes needed to load the address LLRs (Low Level Resources). These signals are buffered to drive the address LLRs and HLRs (High Level Resources).

The Mapper RAMs are used to determine which Counter RAM location to increment based on the address present on the emulation bus. The RUN mode forces the RAMs into a constant read enable state. The Load/Unload mode provides the address and data to the RAMs. The RAMs are mapped directly into the CPU's address space with the only restriction being that they are in the Load/Unload mode.

The Counter Circuitry is responsible for the following: First the counter pointer is latched into the counter pointer register. Then the contents of that RAM location are latched into the previous number latch. That value is then passed to the incrementer which adds 1 to it (except upon overflow). Then the output of the incrementer is loaded back into the RAM at the same location. When the measurement is done, the count values are unloaded by loading the counter pointer register and reading the values from the count data port. The counter RAMs are cleared by writing a zero to the previous number latch, disabling the incrementer, and manually clocking the outputs into all the RAM locations.

The ID generator takes a combination of signals which creates the ID of 1009 HEX for the Acquisition board.

The 10 Mhz Clock is generated from a 20 Mhz clock that is divided by two.

There are only three banks of Recognition Logic on the Acquisition board: 1) Low level data recognition (LLR), 2) Low level address recognition (LLR), 3) High level recognition (HLR). The sample emulation data bus is connected to all the data recognition chips in parallel. The sample emulation address and status bus are connected to all the address recognition chips with the status bus being connected to the most significant bits. This allows the ranging on address with a given status pattern. All of the used outputs of the LLRs, address and data LLRs, are connected to all of the inputs of the HLRs. Any HLR can be programmed to recognize any pattern of inputs corresponding to a desired pattern on the sample emulation bus coupled with a given occurrence count and IMB condition. The outputs of the HLRs are buffered into signals HLR0-9. These signals are used by both the Control board and Acquisition memory.

There are four latches for the address and status busses. The latches are clocked on the rising edge of the analysis clock.

There are three data bus latches. All byte transactions are steered to the lower bus so that they are in a known place to be used later. This prevents the latches from being tied up during other operations. The IMB signals are taken off the IMB tab and transferred directly to the Control board on J3. There is no IMB circuitry on the Acquisition board.

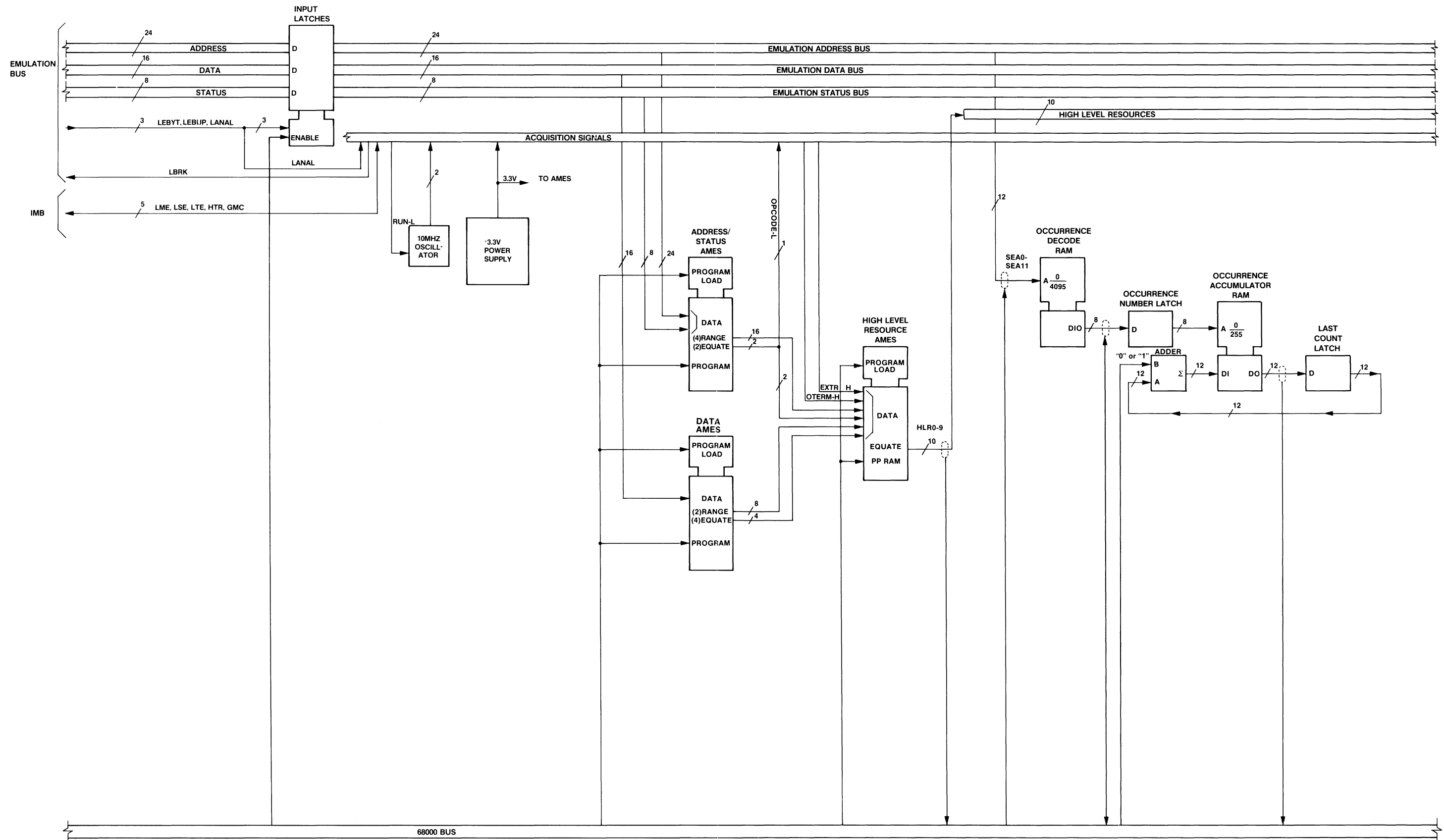

Figure 3-2.
Acquisition Board Block Diagram
3-7

Control Board Block Theory

The Timing Generator on the Control board generates the various clocks used by three HP 64340A boards. Five major timing signals are produced. These are: "Clock 1", "Clock 2", "Clock 3", "Clock 4", and "Clock 6". The "Low Analyzer" signal is routed from the Emulation bus connector on the Acquisition board to the Control board via the HP 64340A inter-board bus.

All other clocks generated by the timing generator are done using ECL logic. Signals going in and clocks coming out go thru level translators. There are three adjustable delay generators, each with an adjustable resistor.

TP3 is used as a reference for calibration. The HP 64340A has three "edges" that need to be calibrated with respect to the reference edge. "Clock 3" (TP2) needs both its rising and falling edges calibrated. "Clock 6" (TP1) needs its falling edge calibrated. Adjustable resistor R2 controls the delay between the rising edge on TP3 (the reference), and the falling edge on TP2. Adjustable resistor R3 controls the delay between the falling edge on TP2 and the rising edge on TP2. Adjustable resistor R1 controls the delay between the rising edge of "Clock 2" and the falling edge on TP1.

The "X" and "Y" Function Generators translate general purpose, high level resource from the Acquisition board into special purpose, dedicated functions. The dedicated functions produced are used to control specific parts of the HP 64340A Software Analyzer. For example, the "Store" function determines whether or not the current cycle will be stored in Acquisition memory.

The "X" and "Y" Function Generator has three major parts. These are: the X Generator, the Y Generator, and the Dedicated Functions Generator. Signals from the X and Y Generators are combined by the Dedicated Functions Generator to produce the nine following dedicated functions: Start, Timer Count, Timer Load, Occurrence, Count, Store, Search (and Search Done), and Sequence Start.

The X Generator is made up of a 4K deep by 20-bit mapper RAM, a 12-bit multiplexer which selects what goes on the RAM address bus, and a 4-bit latch in the feedback path. Bus transceivers are used to connect the RAM data bus to the common data bus on the Control board.

The Y Function Generator is similar to the X Function Generator. The differences are the following: the Y Generator RAM is 16 bits wide instead of 20 bits. The Y Generator RAM address multiplexer selects a different set of signals.

The Y Generator RAM takes twelve input signals and performs arbitrary, programmable functions on them producing sixteen output signals. Four of these outputs define the "next state" and the rest go to the Dedicated Functions Generator.

The Dedicated Function Generator combines the sixteen signals from the X Generator, the twelve signals from the Y Generator, and three special purpose signals into nine dedicated functions. Six control signals determine which dedicated function(s), if any, are qualified by the "Start" function. The "Search" function can not be qualified by "Start". The "Timer Count" and "Timer Load" functions share a single control signal for "Start" qualification.

Control Board Block Theory (Cont'd)

The Fast-Sequencer consists of a 4K by 48-bit RAM memory, a 5-bit state register, a 12-bit RAM address multiplexer, a 24-bit adder, a 24-bit operand multiplexer, a 24-bit accumulator register, two AME comparator chips, and a 7-bit hold latch.

The Fast-Sequencer takes the Sampled Emulation Address bus, the Sampled Emulation Status bus, and the "Sequence Start" dedicated function as input. It produces four principal outputs from these inputs. These are the following: "Fast-Sequencer Source X", "Fast-Sequencer Source Y", "Fast-Sequencer Store", and "Fast-Sequencer Stop". The "Fast-Sequencer Source X" goes to the X Generator, the "Fast-Sequencer Source Y" goes to the Y Generator, "Fast-Sequencer Store" and "Fast-Sequencer Stop" go to the Dedicated Function Generator.

The "Fast-Sequencer Source X", "Fast-Sequencer Source Y", and "Fast-Sequencer Store" signals also are sent to the Acquisition memory on the HP 64340A CPU board to be stored as flags.

The Fast-Sequencer RAM address bus is driven by a 12-bit multiplexer. This multiplexer selects between the buffered HP 64340A Address bus, used for loading the RAM, and twelve other signals which are used during measurement.

The AME chip is the "heart" of the Fast-Sequencer circuitry. The 24-bit sum from the adder circuit together with the 8-bit status pattern from the Fast-Sequencer RAM can be loaded into one or both of the AME chips on the Control board. The program port on each AME chip directs the 32-bit pattern to one of four registers within the AME chip.

The 32-bit data ports of both AME chips are connected to the 24-bit Sampled Emulation Status bus.

The AME chips require +3.3 volts to operate. This special supply voltage comes from the Acquisition board over six lines on the three inter-board cables.

The Time/State Timer is a flexible, 24-bit counter that can be programmed for a variety of uses. This Timer can count either a 10 Mhz time clock or a state clock.

The Timer is used in two ways. It can be initialized to 000000 HEX before the measurement, and then simply count an event until the end of the measurement. The second way the Timer is used involves active participation in the measurement. The Timer can alter a sequence, cause a state to be stored, or possibly stop the analyzer.

The Occurrence Counter is a multipurpose counter that does "occurrence" and "time interval" functions. The counter can count up to 65,536 and can interact with measurements. As with the Time/State Timer, the Occurrence Counter can be used to count state events during a measurement.

The HP 64340A can drive all five IMB signals and can receive four IMB signals. The one IMB signal that can not be received is the "GMC" signal (may also be referred to as "PDC").

The IMB comes into the HP 64340A board set on the Acquisition board (upper-left tab). The Acquisition board has no logic pertaining to IMB. It merely routes the IMB signals to the center inter-board connector. The Control board has all the driving and receiving circuitry for the IMB.

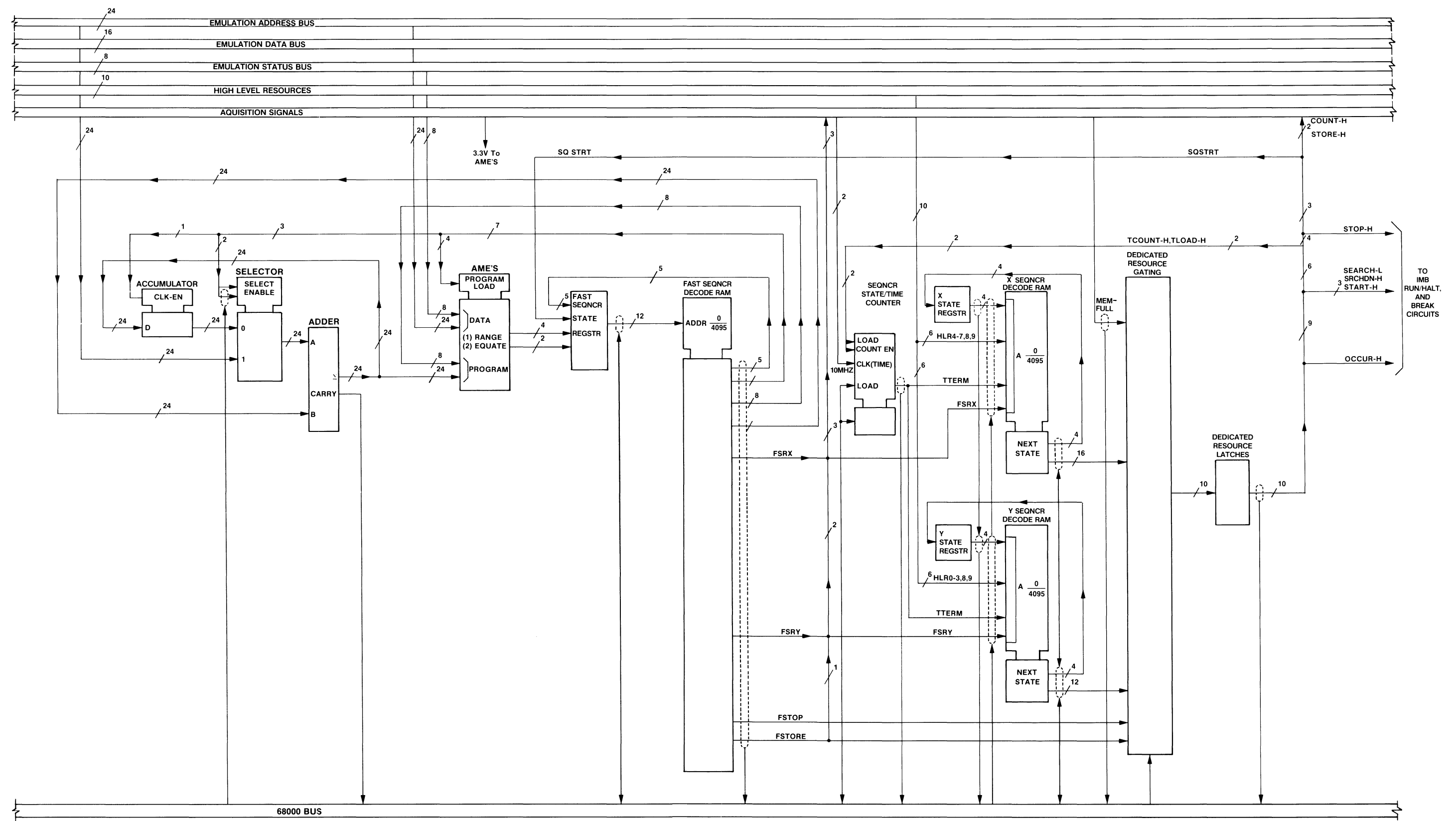

Figure 3-3. Control Board Block Diagram

TROUBLESHOOTING

If a HP 64340A failure is suspected, follow the procedures in the **Troubleshooting Flowchart, table 3-1**. The Troubleshooting Flowchart will aid in isolating the failure to board level. Most of the performance verification tests interact on all three boards. Some failures can not be narrowed down to one board. Always replace the board with highest percentage of failures that occur during performance verification. The following example will give a better understanding to this troubleshooting technique.

EXAMPLE:

The CPU board has 20 tests, the Control board has 19 tests, and the Acquisition board has 6 tests. See figure 3-4.

If the CPU board has 10 failures (out of 20 tests), then $10/20 = .5 \times 100 = 50\%$ of its tests failing. If the Control board has 5 failures (out of 19 tests), then $5/19 = .26 \times 100 = 26\%$ of its tests failing. If the Acquisition board has 5 failures (out of 6 test), then $5/6 = .83 \times 100 = 83\%$ of its tests failing.

In the above example the Acquisition board should be replaced first because 83% of its tests failed. If that does not fix the failure, replace the CPU board next since it had a 50% failure rate. See figure 3-4.

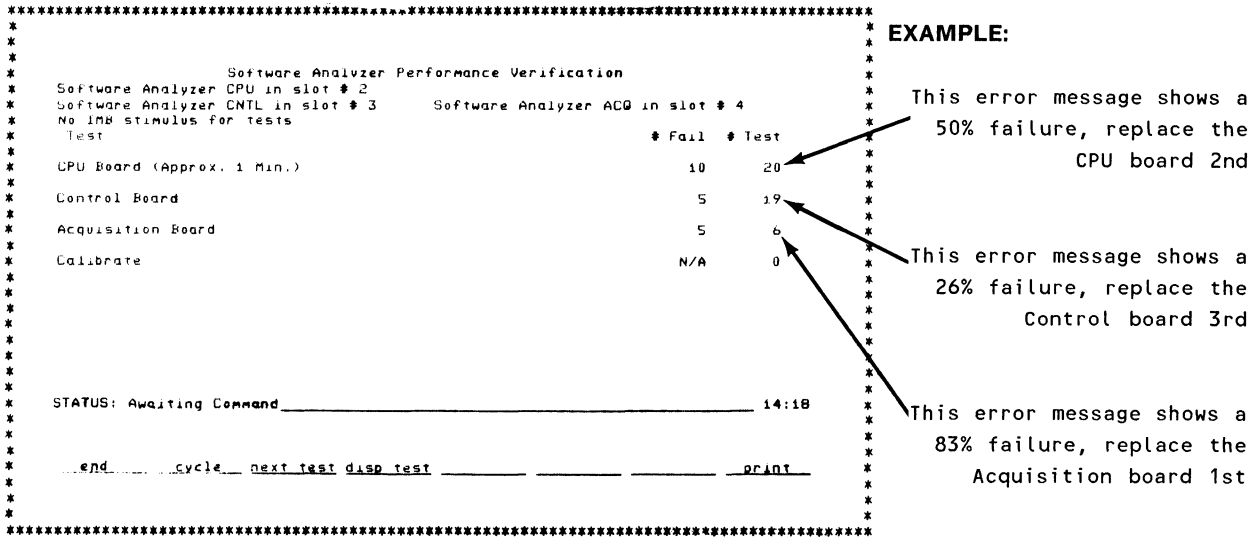

Figure 3-4. Software Analyzer Performance Verification (main test)

NOTE

Always suspect cable and board connections. Reseat all HP 64340A boards/cables before running performance verification.

TROUBLESHOOTING HINTS

- a) Power the development station OFF. Reseat option cards to ensure proper contact to the Motherboard edge connectors. Power development station ON.
- b) Make sure the inter-connect cables are firmly attached to J2, J3, and J4 of each of the three HP 64340A boards.
- c) Power development station OFF. Move the HP 64340A three board set into different option slots to avoid slot-dependent-failures. Power development station ON.

Procedure to Run the HP 64340A Software Analyzer Performance Verification:

- a) Press the [---ETC---] softkey until the [opt _test] softkey is displayed.
- b) Press the [opt _test] softkey, then the RETURN key.
- c) Type in the cardcage slot number where the Software Analyzer CPU, CNTL, or ACQ board resides, then press the RETURN key.
- d) If there are any IMB stimulus boards in the cardcage, the screen will display the message "Select IMB stimulus for test:". Select and type in the IMB stimulus slot number where it resides in the cardcage, then press the RETURN key.

NOTE

By selecting the HP 64340A CPU board for the IMB stimulus, the IMB tests in performance verification will be bypassed.

- e) Press the [cycle] softkey.
- f) To stop the test, press the [cycle] softkey again.
- g) If a failure occurs remove all option boards except for the HP 64340A Module from the development station cardcage.
- h) To exit test, press the [end] softkey.

Procedure to Run the External IMB Performance Verification Test:

- a) Press the [---ETC---] softkey until the [opt _test] softkey is displayed.
- b) Press the [opt _test] softkey, then the RETURN key.

Procedure to Run the External IMB Performance Verification Test (Cont'd):

- c) Type in the cardcage slot number where the Software Analyzer CPU, Acquisition, or the Control board resides, then press the RETURN key.
- d) Type in the cardcage slot number where the IMB Stimulus resides, then press the RETURN key.
- e) Press the [next_test] softkey once so that the "Control Board" test is highlighted.
- f) Press the [disp_test] softkey.
- g) Press the [next_test] softkey four times so that the "IMB Interface" test is highlighted.
- h) Press the [disp_test] softkey.
- i) Press the [next_test] softkey until the "External Stimulus" test is highlighted.
- j) Press the [disp_test] softkey.
- k) Press the [start] softkey to activate test.

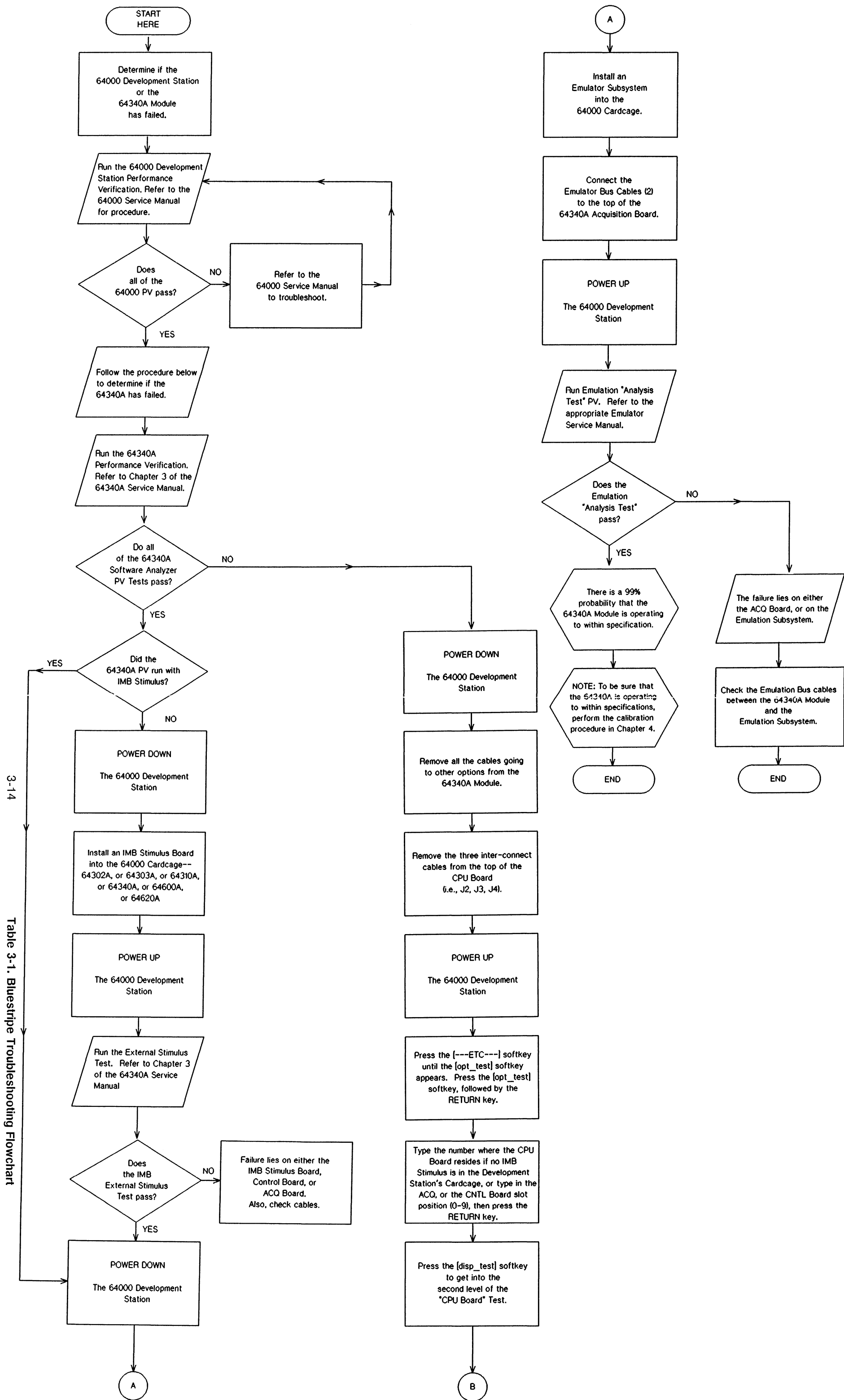

3-14 Table 3-1. Bluestripe Troubleshooting Flowchart

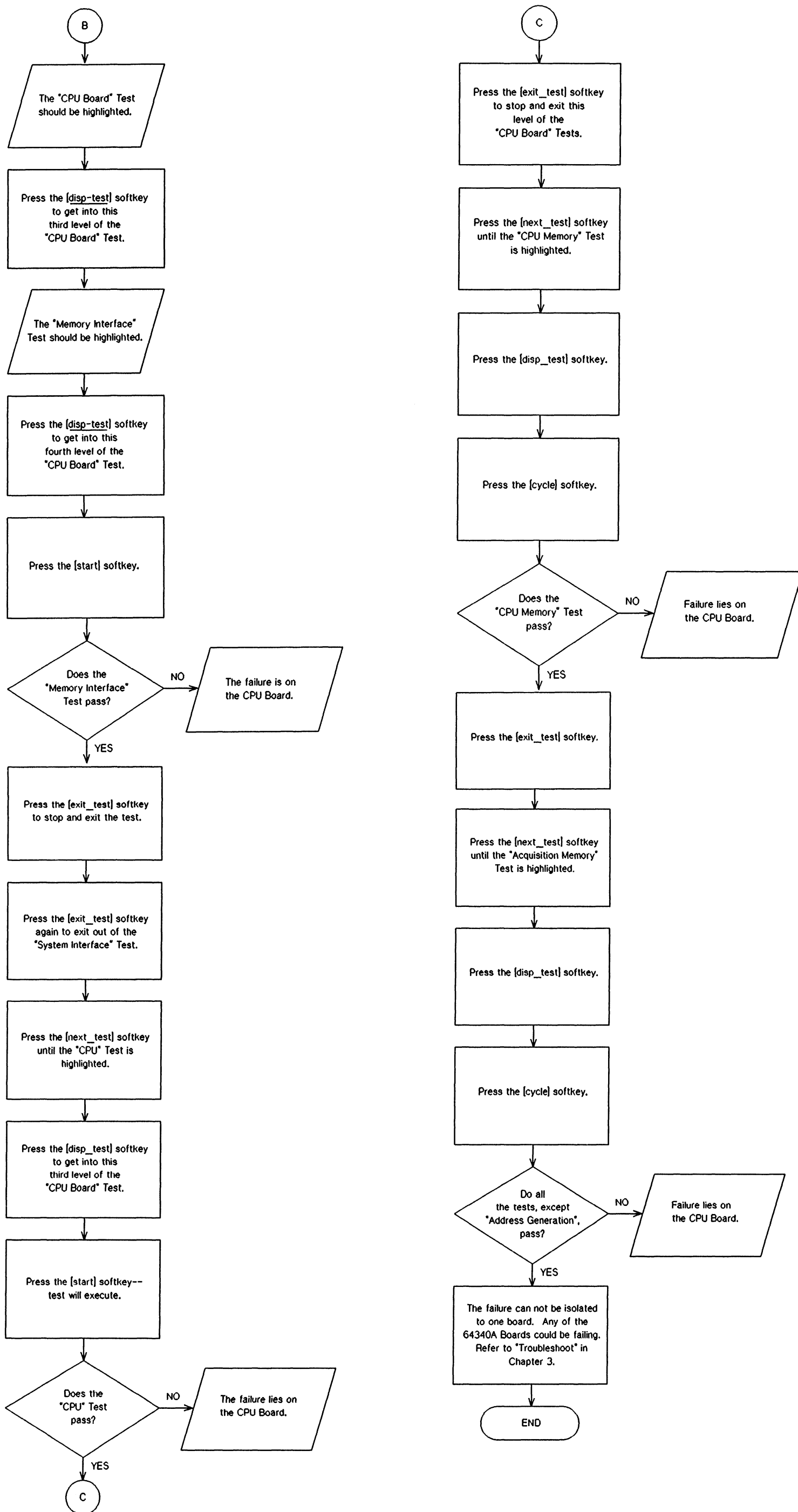

Table 3-1.
Bluestripe Troubleshooting Flowchart (Cont'd)
3-15

```
*****
*
*
*
*           Software Analyzer CPU Board Tests
* Software Analyzer CPU in slot # 3
* Software Analyzer CNTL in slot # 4       Software Analyzer ACQ in slot # 5
* No IMB stimulus for tests
*
*           # Fail  # Test
*
* System Interface                0      0
*
* CPU                             0      0
*
* CPU Memory (Approx. 38 Seconds)  0      0
*
* Acquisition Memory              0      0
*
* Floating Point Counter          0      0
*
* Auxiliary Circuits              0      0
*
*
* STATUS: Awaiting Command_____ 14:18
*
*
*
*   _____ cycle  next test disp test exit test _____ print
*
*
*
*****
```

Figure 3-6. Software Analyzer CPU Board Tests (second level)

```
*****
*
*
*           Software Analyzer CPU Board -- System Interface Tests
* Software Analyzer CPU in slot # 3
* Software Analyzer CNTL in slot # 4       Software Analyzer ACQ in slot # 5
* No IMB stimulus for tests
*
*           # Fail  # Test
*
* Memory Interface                0      0
*
* Control Register                0      0
*
*
*
*
*
*
*
*
* STATUS: Awaiting Command_____ 14:18
*
*
*
*   _____ cycle  next test disp test exit test _____ print
*
*
*
*****
```

Figure 3-7. CPU Board - System Interface Tests (third level)

```

*****
*
*
*
*
*           Software Analyzer CPU Board -- CPU Memory Tests
*
* Software Analyzer CPU in slot # 3
* Software Analyzer CNTL in slot # 4           Software Analyzer ACQ in slot # 5
* No IMB stimulus for tests
*
* Test                               Error Code (Cumulative)   # Fail   # Test
* CPU Memory
*
*      [0 - 16k] (approx. 3 sec.)                0         0
*
*
*
*
*      [16k - 256k] (approx. 35 sec.)            0         0
*
*
*
*
* STATUS: Awaiting Command_____ 14:18
*
*
*
*
*      _____ cycle  next test  start  exit test  _____ print
*
*
*
*
*****

```

Figure 3-10. CPU Board - CPU Memory Tests (third level)

```

*****
*
*
*
*           Software Analyzer CPU Board -- Acquisition Memory tests
*
* Software Analyzer CPU in slot # 3
* Software Analyzer CNTL in slot # 4           Software Analyzer ACQ in slot # 5
* No IMB stimulus for tests
*
* Test                               # Fail   # Test
*
* Address Generation                    0         0
*
* Control                               0         0
*
* Data RAM                              0         0
* Address RAM                           0         0
* Status/Address RAM                    0         0
*
* Opcode RAM                            0         0
* Flag/Count/Opcod RAM                  0         0
* Count RAM                             0         0
*
*
*
*
* STATUS: Awaiting Command_____ 14:18
*
*
*
*
*      _____ cycle  next test  disp test  exit test  _____ print
*
*
*
*
*****

```

Figure 3-11. CPU Board - Acquisition Memory Tests (third level)

```

*****
*
*
*               Software Analyzer Control Board Tests
* Software Analyzer CPU in slot # 3
* Software Analyzer CNTL in slot # 4      Software Analyzer ACQ in slot # 5
* No IMB stimulus for tests
* Test                                     # Fail # Test
*
* RAM                                     0      0
*
* Function Generator                       0      0
*
* Fast Sequencer                           0      0
*
* Counters                                 0      0
*
* IMB Interface                            0      0
*
* Run Mode                                  0      0
*
*
*
* STATUS: Awaiting Command_____ 14:18
*
*
* _____ cycle next test disp test exit test _____ print
*
*
*****

```

Figure 3-12. Control Board - Control Board Tests (second level)

```

*****
*
*
*               Software Analyzer Control Board -- IMB Interface tests
* Software Analyzer CPU in slot # 3
* Software Analyzer CNTL in slot # 4      Software Analyzer ACQ in slot # 5
* IMB Extender in slot # 6 for IMB stimulus
* Test                                     # Fail # Test
*
* Internal Stimulus                         0      0
*
* External Stimulus                         0      0
*
*
*
*
*
*
*
*
*
*
* STATUS: Awaiting Command_____ 14:18
*
*
* _____ cycle next test disp test exit test _____ print
*
*
*****

```

Figure 3-13. Control Board - IMB Interface Tests (third level)

```

*****
*
*
*
*      Software Analyzer Control Board -- IMB Interface Tests
*
*      Software Analyzer CPU in slot # 3
*      Software Analyzer CNTL in slot # 4      Software Analyzer ACQ in slot # 5
*      Wide Emul. Analysis in slot # 6 for IMB stimulus
*
*      Test      Error Code (Cumulative)      # Fail # Test
*
*      External Stimulus
*          Drive Master Enable (LME)      0      (0)
*          Drive Trigger Enable (LTE)      0      (0)
*          Drive Storage Enable (LSE)      --UNABLE TO TEST--
*          Drive Trigger (HTR)      0      (0)
*          Drive Gated Master Clock (GMC)  --UNABLE TO TEST--
*
*          Receive Master Enable (LME)      0      (0)
*          Receive Trigger Enable (LTE)      0      (0)
*          Receive Storage Enable (LSE)      --UNABLE TO TEST--
*          Receive Trigger (HTR)      0      (0)
*
*
*
*
*
*
*
*
*
*      STATUS: Awaiting Command_____ 14:18
*
*
*
*      _____ start _____ exit test _____ print _____
*
*
*
*****

```

Figure 3-14. Control Board - External Stimulus Test (fourth level)

```

*****
*
*
*
*      Software Analyzer Performance Verification
*
*      No Software Analyzer CPU for tests
*      Software Analyzer CNTL in slot # 7      Software Analyzer ACQ in slot # 8
*      IMB Extender in slot # 9 for IMB stimulus
*
*
*
*      Unable to execute Performance Verification:
*
*          Software Analyzer CPU card not present
*
*
*
*
*
*
*
*
*
*
*
*
*
*
*
*      STATUS: Awaiting Command_____ 14:18
*
*
*
*      _____ end _____ start _____ print _____
*
*
*
*****

```

Figure 3-15. CPU Board Missing Message

```
*****
*
*
*
*      Software Analyzer Performance Verification
* Software Analyzer CPU in slot # 6
* No Software Analyzer CNTL for tests      No Software Analyzer ACU for tests
* No IMB stimulus for tests
* Test                                     # Fail  # Test
*
* CPU Board (Some tests Not Cycled Thru)                0      0
* Control Board                                         0      0
* Acquisition Board                                    0      0
* Calibrate                                            N/A    N/A
*
*
*
*
*
*
*
*
*
* STATUS: Awaiting Command_____ 14:18
*
*
*
*   _____ start   exit test   _____ print
*
*
*
*
*****
```

Figure 3-16. Incomplete Set of Cards Message

```
*****
*
*
*
*      68000 Emulation System Performance Verification
*
* General Purpose Controller with 68000 pod in card slot # 8
* Test           Error Code (Cumulative)  # Fail  # Test
* Analysis Stimulus                                     0      0
*
*
*
*
*
*
*
*
*
*
* STATUS: Awaiting Command_____ 14:18
*
*
*
*   _____ start   exit test   _____ print
*
*
*
*
*****
```

Figure 3-17. Emulation Analysis Screen - Test Can Be Executed

```
*****  
*  
*  
*          68000 Emulation System Performance Verification          *  
*  
* General Purpose Controller with 68000 pod in card slot # 8      *  
*  
* Unable to execute Analysis Stimulus test:                       *  
*   Software Analyzer CNTL board not present                       *  
*  
*  
*  
*  
*  
*  
*  
*  
*  
*  
*  
* STATUS: Awaiting Command_____ 14:18                          *  
*  
*  
* _____ start  exit test _____ print _____          *  
*  
*  
*  
*****
```

Figure 3-18. Emulation Analysis Screen - No Control Board

```
*****  
*  
*  
*          68000 Emulation System Performance Verification          *  
*  
* General Purpose Controller with 68000 pod in card slot # 8      *  
*  
* Unable to execute Analysis Stimulus test:                       *  
*   Software Analyzer ACQ board not present                       *  
*  
*  
*  
*  
*  
*  
*  
*  
*  
*  
*  
*  
*  
* STATUS: Awaiting Command_____ 14:18                          *  
*  
*  
* _____ start  exit test _____ print _____          *  
*  
*  
*  
*****
```

Figure 3-19. Emulation Analysis Screen - No ACQ Board

```

*****
*
*
*
*          68000 Emulation System Performance Verification
*
*  General Purpose Controller with 68000 pod in card slot # 8
*
*  Unable to execute Analysis Stimulus test:
*    Software Analyzer CNTL board not present
*    Software Analyzer ACQ board not present
*
*
*
*
*
*
*
*
*  STATUS: Awaiting Command_____ 14:18
*
*
*          _____ start  exit test  _____ print
*
*
*****
  
```

Figure 3-20. Emulation Analysis Screen - No Control and ACQ Boards

```

*****
*
*
*
*          68000 Emulation System Performance Verification
*
*  General Purpose Controller with 68000 pod in card slot # 8
*
*  Unable to execute Analysis Stimulus test:
*    Software Analyzer hardware failure
*
*
*
*
*
*
*
*
*  STATUS: Awaiting Command_____ 14:18
*
*
*          _____ start  exit test  _____ print
*
*
*****
  
```

figure 3-21. CPU Fails Handshake

```
*****  
*  
*  
*  
*          68000 Emulation System Performance Verification          *  
*  
* General Purpose Controller with 68000 pod in card slot # 8      *  
*  
* Unable to execute Analysis Stimulus test:                       *  
*   File = sw_anlpv3:HP:absolute not present                     *  
*  
*  
*  
*  
*  
*  
*  
*  
*  
*  
*  
*  
*  
*  
* STATUS: Awaiting Command _____ 14:18                      *  
*  
*  
*  
* _____ start  exit test _____ print _____        *  
*  
*  
*  
*****
```

Figure 3-22. File Containing 68000 Stimulus Code Missing

NOTES

Chapter 4

ADJUSTMENTS

INTRODUCTION

This chapter describes the adjustment required to return the instrument to within operating specifications. Periodical maintenance is required on the 64340-66502 Control board after approximately one year of use. Follow the calibration procedures outlined in this section to make the adjustments necessary to bring the Control board clock signals to within specifications.

SAFETY REQUIREMENTS

Read the Safety Summary at the front of this manual before attempting any adjustments on the HP 64340A Software Analyzer. Failure to observe these safety procedures could result in personal injury or damage to the instrument. **Any adjustments required should be performed only by qualified personnel.**

EQUIPMENT REQUIRED

The following test equipment is required to perform the calibration procedure on the 64340-66502 Control board:

HP 64100A Logic Development Station
HP 64340A Software Analyzer (3 board set)
1726A Oscilloscope (275MHz)
10017A Scope probe (Qty 2)
64110-66503 Extender board (3)

CALIBRATION PROCEDURE

- a) Install the HP 64340A boards into the 64000 Logic Development Station. All three boards must be installed on extender boards. The Control board (64340-66502) must be placed in front of the other two boards to perform the procedure. The CPU board (64340-66501) should be placed in the middle, and the Acquisition board (64340-66503) should be placed in the rear of the cardcage. Power on the HP 64100A.
- b) Turn ON HP 64100A Logic Development Station and allow HP 64340A Module to warm up for 5 minutes.
- c) Press the [---ETC---] softkey until the [opt_test] softkey appears.
- d) Press the [opt_test] softkey, then the RETURN key.
- e) Type in the slot number where any one of the three HP 64340A boards resides in the cardcage, then press the RETURN key.
- f) If IMB stimulus is present, type in an IMB stimulus slot number where the board resides in the cardcage.

NOTE

The HP 64340A CPU board can be selected as the IMB stimulus, but this will disable the IMB tests. During calibration the IMB tests are not used.

- g) Press the [next_test] softkey until the "Calibrate" test is highlighted.
- h) Press the [start] softkey to activate the test.
- i) Connect the scope to the Control board as follows;

Channel A	: TP3 .1V/div	Main sweep	: .05 usec/div
Channel B	: TP2 .1V/div	Delayed sweep	: .02 usec/div
Vert Display	: ALT		
Trigger	: Ch A		
polarity	: " - "		

- j) Set both channels to GND. Adjust the "position control" so that the traces are 1.3 divisions below the center line of the display on the oscilloscope.

NOTE

All procedures take place on the 64340-66502 Control board.

- k) Adjust R2 for 135 +/- 0.5 ns delay between the rising edge of TP3 and the falling edge of TP2. Use the 1.3 volt crossing to make the measurement. See figure 4-1.
- l) Adjust R3 for 180 +/- 0.5 ns delay between the rising edge of TP3 and the rising edge of TP2. Make the measurement at the 1.3 volt crossing of the waveform. See figure 4-1.
- m) Connect the scope probe channel B to TP1.
- n) Adjust R1 for 225 +/- 1 ns delay between the rising edge of TP3 and the falling edge of TP1. Make the measurement at the 1.3 volt crossing of the waveform. See figure 4-1.

NOTE

Recheck the above measurements to insure that all still meet the specifications since the R3 and R1 adjustments interact with the R2 adjustment.

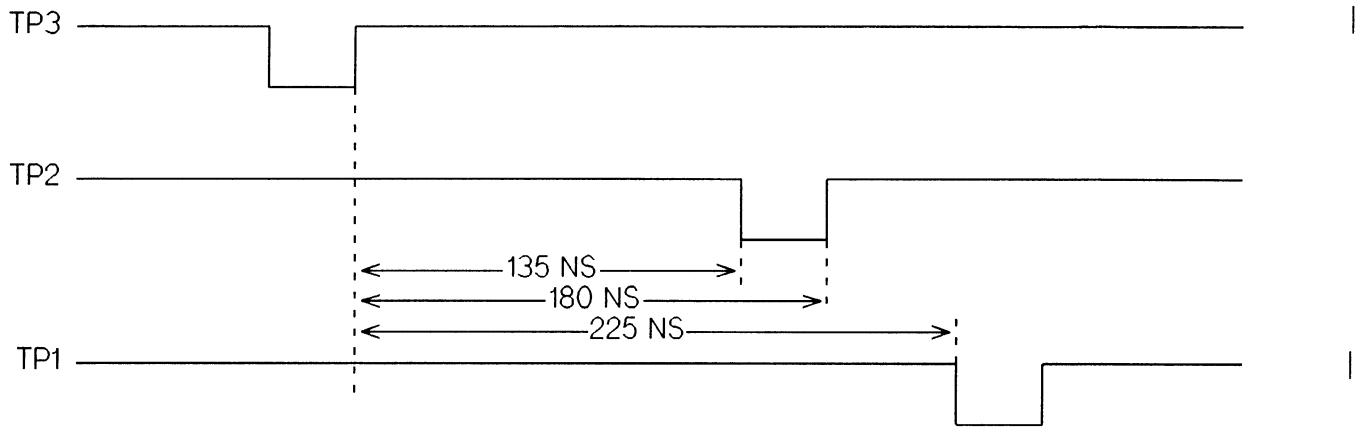

Figure 4-1. Calibration Timing Relationship

NOTES

Chapter 5

REPLACEABLE PARTS

INTRODUCTION

This section contains information for ordering parts for the Software Data Analyzer. Table 6-1 lists parts that may be ordered directly for the Model 64340A. Table 5-2 lists abbreviations that may be used throughout the manual.

REPLACEABLE PARTS

Table 5-1 shows part numbers for replaceable parts for the Model 64340A Software Analyzer.

Table 5-1. Replaceable Parts

Reference Designator	CD	Qty	Description	Part Number
A1	5	1	CPU BOARD ASSEMBLY	64340-69501
A2	6	1	CNTL BOARD ASSEMBLY	64340-69502
A3	7	1	ACQ BOARD ASSEMBLY	64340-69503
W1	6	3	INTER-CONNECT CABLE	64340-61601
H1	0	3	64340A PC EXTRACTOR	64340-85001
H2	1	1	CPU BD EXTRACTOR	64340-85002
H3	2	1	CNTL BD EXTRACTOR	64340-85003
H4	3	1	ACQ BD EXTRACTOR	64340-85004

ABBREVIATIONS

Table 5-2 lists abbreviations that may be used in this manual. The designators and abbreviations are presented in upper cased letters and their definitions are lower cased.

Table 5-2. Reference Designators and Abbreviations

REFERENCE DESIGNATORS

A = assembly	F = fuse	MP = mechanical part	U = integrated circuit
B = motor	FL = filter	P = plug	V = vacuum, tube, neon bulb, photocell, etc
BT = battery	IC = integrated circuit	Q = transistor	VR = voltage regulator
C = capacitor	J = jack	R = resistor	W = cable
CP = coupler	K = relay	RT = thermistor	X = socket
CR = diode	L = inductor	S = switch	Y = crystal
DL = delay line	LS = loud speaker	T = transformer	Z = tuned cavity network
DS = device signaling (lamp)	M = meter	TB = terminal board	
E = misc electronic part	MK = microphone	TP = test point	

ABBREVIATIONS

A = amperes	H = henries	N/O = normally open	RMO = rack mount only
AFC = automatic frequency control	HDW = hardware	NOM = nominal	RMS = root-mean square
AMPL = amplifier	HEX = hexagonal	NPO = negative positive zero (zero temperature coefficient)	RWV = reverse working voltage
BFO = beat frequency oscillator	HG = mercury	NPN = negative-positive-negative	S-B = slow-blow
BE CU = beryllium copper	HR = hour(s)	NRFR = not recommended for field replacement	SCR = screw
BH = binder head	HZ = hertz	NSR = not separately replaceable	SE = selenium
BP = bandpass	IF = intermediate freq	OB = order by description	SECT = section(s)
BRS = brass	IMPG = impregnated	OH = oval head	SEMICON = semiconductor
BWO = backward wave oscillator	INCD = incandescent	OX = oxide	SI = silicon
CCW = counter-clockwise	INCL = include(s)	P = peak	SIL = silver
CER = ceramic	INS = insulation(ed)	PC = printed circuit	SL = slide
CMO = cabinet mount only	INT = internal	PF = picofarads= 10 ⁻¹² farads	SPG = spring
COEF = coefficient	K = kilo=1000	PH BRZ = phosphor bronze	SPL = special
COM = common	LH = left hand	PHL = phillips	SST = stainless steel
COMP = composition	LIN = linear taper	PIV = peak inverse voltage	SR = split ring
COMPL = complete	LK WASH = lock washer	PNP = positive-negative-positive	STL = steel
CONN = connector	LOG = logarithmic taper	P/O = part of	TA = tantalum
CP = cadmium plate	LPF = low pass filter	POLY = polystyrene	TD = time delay
CRT = cathode-ray tube	M = milli=10 ⁻³	PORC = porcelain	TGL = toggle
CW = clockwise	MEG = meg=10 ⁶	POS = position(s)	THD = thread
DEPC = deposited carbon	MET FLM = metal film	POT = potentiometer	TI = titanium
DR = drive	MET OX = metallic oxide	PP = peak-to-peak	TOL = tolerance
ELECT = electrolytic	MFR = manufacturer	PT = point	TRIM = trimmer
ENCAP = encapsulated	MHZ = mega hertz	PWV = peak working voltage	TWT = traveling wave tube
EXT = external	MINAT = miniature	RECT = rectifier	U = micro=10 ⁻⁶
F = farads	MOM = momentary	RF = radio frequency	VAR = variable
FH = flat head	MOS = metal oxide substrate	RH = round head or right hand	VDCW = dc working volts
FIL H = fillister head	MTG = mounting		W/ = with
FXD = fixed	MY = "mylar"		W = watts
G = giga (10 ⁹)	N = nano (10 ⁻⁹)		WIV = working inverse voltage
GE = germanium	N/C = normally closed		WW = wirewound
GL = glass	NE = neon		W/O = without
GRD = grounded)	NI PL = nickel plate		

A3 ACQUISITION BD

A1 CPU BD

A2 CONTROL BOARD

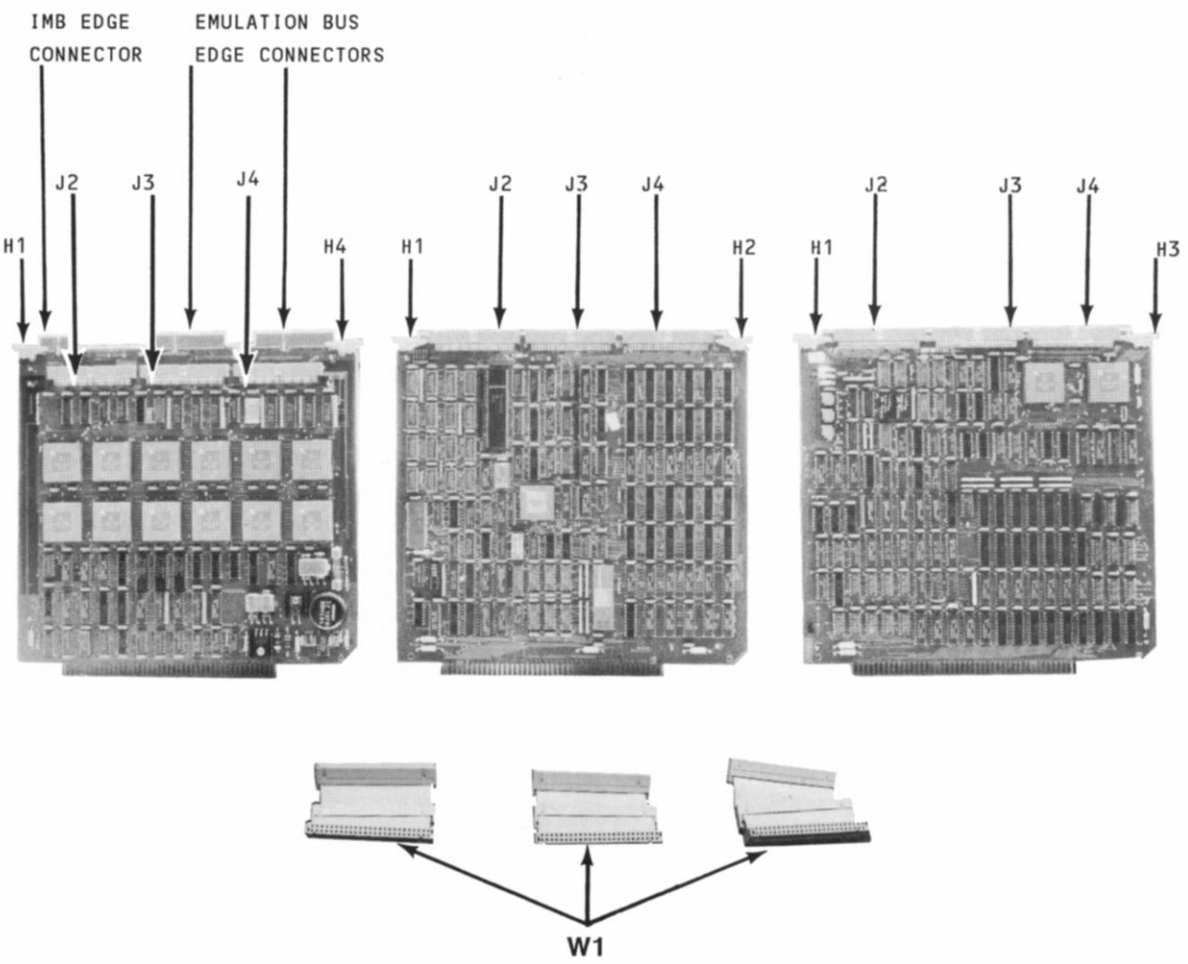

Figure 5-1. Reference Designator Breakdown

NOTES

Chapter 6

MANUAL CHANGES

INTRODUCTION

This chapter normally contains information required to backdate or update this manual for a specific instrument. Since the information in this manual applies directly to HP 64340A Software Analyzer with the serial prefixes listed on the title page, no change information is given.

NOTES

Index

A

Abbreviations	5-1
Accessories Supplied	1-3
Acquisition Board Block Diagram (figure 3-2).	3-7
Acquisition Board Block Theory	3-6

B

Block Description - General	3-3
Block Diagram - Acquisition Board (figure 3-2)	3-7
Block Diagram - CPU Board (figure 3-1)	3-5
Block Diagram - Control Board (figure 3-3)	3-10
Block Theory - Acquisition Board.	3-6
Block Theory - CPU Board	3-4
Block Theory - Control Board	3-8
Bluestripe Troubleshooting Flowchart (table 3-1)	3-14

C

CAUTION	2-12
CPU Board - Acquisition Memory Tests (third level screen)	3-19
CPU Board - CPU Memory Tests (third level screen)	3-19
CPU Board - CPU Tests (third level screen)	3-18
CPU Board - System Interface Tests (third level screen)	3-17
CPU Board Block Diagram (figure 3-1)	3-5
CPU Board Block Theory.	3-4
CPU Board Missing Message (screen)	3-21
CPU Fails Handshake (screen)	3-24
Cable Options [68000] - (table 2-1)	2-2
Cable Options [80186] - (table 2-2)	2-6
Calibration Procedure	4-1
Cardcage Cover Removal (figure 2-1)	2-9
Configurations [68000] - Hardware (table 2-1)	2-2
Configurations [80186] - Hardware (table 2-2)	2-6
Control Board - Control Board Tests (second level screen)	3-20
Control Board - External Stimulus Test (fourth level screen)	3-21
Control Board - IMB Interface Tests (third level screen)	3-20
Control Board Block Diagram (figure 3-3)	3-10
Control Board Block Theory.	3-8
Current Usages [68000] - (table 2-1)	2-2
Current Usages [80186] - (table 2-2)	2-6

Index (Cont'd)

E

Electrical Specifications	1-2
Emulation Analysis Screen - No ACQ Board (screen)	3-23
Emulation Analysis Screen - No Control Board (screen)	3-23
Emulation Analysis Screen - No Control and ACQ Boards (screen)	3-24
Emulation Analysis Screen - Test Can Be Executed (screen)	3-22
Environment - Operating	2-11
Environment	2-11
Equipment Required But Not Supplied	1-3
Equipment Required	4-1

F

File Containing the 68000 Stimulus Code Missing (screen)	3-25
--	------

G

General Block Description of the HP 64340A Hardware	3-3
---	-----

H

Hardware Configurations [68000] - (table 2-1)	2-2
Hardware Configurations [80186] - (table 2-2)	2-6

I

Incomplete Set of Cards Message (screen)	3-22
Initial Inspection	2-1
Installing Inter-Connect Cables to the Acquisition Board (figure 2-2)	2-10
Installing the 64340A in a 64100A Logic Development Station (fig. 2-3)	2-10
Installation	2-1
Instruments Covered By This Manual	1-1

M

Manual Organization	1-1
---------------------------	-----

O

Operating Environment	2-11
Original Packaging	2-11

Index (Cont'd)

P

Performance Verification Test Displays	3-16
Performance Verification	3-1
Power Down the System Under Test	2-12
Procedure To Install the HP 64340A Module	2-1
Procedure To Run Main Test Performance Verification	3-1
Procedure To Run the HP 64340A Software Analyzer Performance Verification	3-12
Procedure To Run the External IMB Performance Verification Test	3-12
Protect Against Static Discharge	2-5

R

Reference Designator Breakdown (figure 5-1)	5-3
Reference Designators and Abbreviations (table 5-2)	5-2
Replaceable Parts (table 5-1)	5-1

S

Safety Requirements	4-1
Softkey Description - Standard Option Test	3-2
Software Analyzer CPU Board Test (second level screen)	3-17
Software Analyzer Description	1-3
Software Analyzer Performance Verification (first level screen)	3-16
Software Analyzer Performance Verification (main test screen)	3-11
Software Analyzer Subsystem Description	3-3
Standard Option Test	3-2
Storage and Shipment	2-11

T

Theory and Troubleshooting	3-3
Theory of Operation	3-3
Troubleshooting Flowchart (table 3-1)	3-14
Troubleshooting Hints	3-12
Troubleshooting	3-11

NOTES

SALES & SUPPORT OFFICES

Arranged alphabetically by country



Product Line Sales/Support Key

Key Product Line

A Analytical

CM Components

C Computer Systems Sales only

CH Computer Systems Hardware Sales and Services

CS Computer Systems Software Sales and Services

E Electronic Instruments & Measurement Systems

M Medical Products

P Personal Computation Products

* Sales only for specific product line

** Support only for specific product line

IMPORTANT: These symbols designate general product line capability. They do not insure sales or support availability for all products within a line, at all locations. Contact your local sales office for information regarding locations where HP support is available for specific products.

HP distributors are printed in italics.

HEADQUARTERS OFFICES

If there is no sales office listed for your area, contact one of these headquarters offices.

AFRICA AND MIDDLE EAST

Hewlett-Packard S.A.
Mediterranean and Middle East Operations
Atrina Centre
32 Kifissias Ave.
Paradissos-Amarousion, **ATHENS**
Greece
Tel: 682 88 11
Telex: 21-6588 HPAT GR
Cable: HEWPACKSA Athens

NORTH/CENTRAL AFRICA

Hewlett-Packard S.A.
7, Rue du Bois-du-Lan
CH-1217 **MEYRIN 2**, Switzerland
Tel: (022) 83 12 12
Telex: 27835 hpse
Cable: HEWPACKSA Geneve

ASIA

Hewlett-Packard Asia Ltd.
47/F, 26 Harbour Rd.,
Wanchai, **HONG KONG**
G.P.O. Box 863, Hong Kong
Tel: 5-8330833
Telex: 76793 HPA HX
Cable: HPASIAL TD

CANADA

Hewlett-Packard (Canada) Ltd.
6877 Goreway Drive
MISSISSAUGA, Ontario L4V 1M8
Tel: (416) 678-9430
Telex: 610-492-4246

EASTERN EUROPE

Hewlett-Packard Ges.m.b.h.
Lieblgasse 1
P.O. Box 72
A-1222 **VIENNA**, Austria
Tel: (222) 2365110
Telex: 1 3 4425 HEPA A

NORTHERN EUROPE

Hewlett-Packard S.A.
Uilenstede 475
P.O. Box 999
NL-1180 **AZ AMSTELVEEN**
The Netherlands
Tel: 20 437771

SOUTH EAST EUROPE

Hewlett-Packard S.A.
World Trade Center
110 Avenue Louis Carol
1215 Cointrin, **GENEVA**, Switzerland
Tel: (022) 98 96 51
Telex: 27225 hpse.

EASTERN USA

Hewlett-Packard Co.
4 Choke Cherry Road
ROCKVILLE, MD 20850
Tel: (301) 258-2000

MIDWESTERN USA

Hewlett-Packard Co.
5201 Tollview Drive
ROLLING MEADOWS, IL 60008
Tel: (312) 255-9800

SOUTHERN USA

Hewlett-Packard Co.
2000 South Park Place
P.O. Box 105005
ATLANTA, GA 30348
Tel: (404) 955-1500

WESTERN USA

Hewlett-Packard Co.
3939 Lankershim Blvd.
P.O. Box 3919
LOS ANGELES, CA 91604
Tel: (213) 506-3700

OTHER INTERNATIONAL AREAS

Hewlett-Packard Co.
Intercontinental Headquarters
3495 Deer Creek Road
PALO ALTO, CA 94304
Tel: (415) 857-1501
Telex: 034-8300
Cable: HEWPACK

ANGOLA

Telectra
Empresa TAEcnica de Equipamentos
R. Barbosa Rodrigues, 41-I DT.
Caixa Postal 6487

LUANDA

Tel: 35515,35516
E,P

ARGENTINA

Hewlett-Packard Argentina S.A.
Avenida Santa Fe 2035
Martinez 1640 **BUENOS AIRES**
Tel: 798-5735, 792-1293
Cable: HEWPACKARG
A,E,CH,CS,P

AUSTRALIA

Adelaide, South Australia Office

Hewlett-Packard Australia Ltd.
153 Greenhill Road
PARKSIDE, S.A. 5063
Tel: 272-5911
Telex: 82536
Cable: HEWPARD Adelaide
A*,CH,CM,CS,E,M,P

Brisbane, Queensland Office

Hewlett-Packard Australia Ltd.
10 Payne Road
THE GAP, Queensland 4061
Tel: 30-4133
Telex: 42133
Cable: HEWPARD Brisbane
A,CH,CS,CM,E,M,P

Canberra, Australia

Capital Territory Office
Hewlett-Packard Australia Ltd.
121 Wollongong Street
FYSHWICK, A.C.T. 2609
Tel: 80 4244
Telex: 62650
Cable: HEWPARD Canberra
C,CH,CM,CS,E,P

Melbourne, Victoria

Office
Hewlett-Packard Australia Ltd.
31-41 Joseph Street
BLACKBURN, Victoria 3130
Tel: 895-2895
Telex: 31-024
Cable: HEWPARD Melbourne
A,CH,CM,CS,E,M,P

Perth, Western Australia

Office
Hewlett-Packard Australia Ltd.
261 Stirling Highway
CLAREMONT, W.A. 6010
Tel: 383-2188
Telex: 93859
Cable: HEWPARD Perth
A,CH,CM,CS,E,M,P

Sydney, New South

Wales Office
Hewlett-Packard Australia Ltd.
17-23 Talavera Road
P.O. Box 308
NORTH RYDE, N.S.W. 2113
Tel: 888-4444
Telex: 21561
Cable: HEWPARD Sydney
A,CH,CM,CS,E,M,P

AUSTRIA

Hewlett-Packard Ges.m.b.h.
Grottenhofstrasse 94
A-8052 **GRAZ**
Tel: (0316) 291 5 66
Telex: 32375
CH,E

Hewlett-Packard Ges.m.b.h.

Lieblgasse 1
P.O. Box 72
A-1222 **VIENNA**
Tel: (0222) 23 65 11-0
Telex: 134425 HEPA A
A,CH,CM,CS,E,M,P

BAHRAIN

Green Salon
P.O. Box 557
Manama
BAHRAIN
Tel: 255503-255950
Telex: 84419
P

Wael Pharmacy

P.O. Box 648

BAHRAIN

Tel: 256123
Telex: 8550 WAEI BN
E,M

BELGIUM

Hewlett-Packard Belgium S.A./N.V.
Blvd de la Woluwe, 100
Woluwedal
B-1200 **BRUSSELS**
Tel: (02) 762-32-00
Telex: 23-494 paloben bru
A,CH,CM,CS,E,M,P

BERMUDA

Applied Computer Technologies
Atlantic House Building
Par-La-Ville Road
Hamilton 5
Tel: 295-1616
P

BRAZIL

Hewlett-Packard do Brasil
I.e.C. Ltda.
Alameda Rio Negro, 750
Alphaville
06400 **BARUERI SP**
Tel: (011) 421.1311
Telex: (011) 33872 HPBR-BR
Cable: HEWPACK Sao Paulo
A,CH,CM,CS,E,M,P



SALES & SUPPORT OFFICES

Arranged alphabetically by country

BRAZIL (Cont'd)

Hewlett-Packard do Brasil
I.e.C. Ltda.
Avenida Epitacio Pessoa, 4664
22471 **RIO DE JANEIRO-RJ**
Tel: (021) 286.0237
Telex: 021-21905 HPBR-BR
Cable: HEWPACK Rio de Janeiro
A,CH,CM,E,M,P*
Convex/Van Den
Rua Jose Bonifacio
458 Todos Os Santos
CEP 20771
RIO DE JANEIRO, RJ
Tel: 249-7121, 591-4946
Telex: 33487
ANAMED I.C.E.I. Ltda.
Rua Bage, 103
04012 SAO PAULO
Tel: (011) 570-5726
Telex: 021-21905 HPBR-BR
M

CANADA

Alberta

Hewlett-Packard (Canada) Ltd.
3030 3rd Avenue N.E.
CALGARY, Alberta T2A 6T7
Tel: (403) 235-3100
A,CH,CM,E*,M,P*
Hewlett-Packard (Canada) Ltd.
11120-178th Street
EDMONTON, Alberta T5S 1P2
Tel: (403) 486-6666
A,CH,CM,CS,E,M,P

British Columbia

Hewlett-Packard (Canada) Ltd.
10691 Shellbridge Way
RICHMOND,
British Columbia V6X 2W7
Tel: (604) 270-2277
Telex: 610-922-5059
A,CH,CM,CS,E*,M,P*
Hewlett-Packard (Canada) Ltd.
121 - 3350 Douglas Street
VICTORIA, British Columbia V8Z 3L1
Tel: (604) 381-6616
CH,CS

Manitoba

Hewlett-Packard (Canada) Ltd.
1825 Inkster Blvd.
WINNIPEG, Manitoba R3H 0Y1
Tel: (204) 786-6701
A,CH,CM,E,M,P*

New Brunswick

Hewlett-Packard (Canada) Ltd.
37 Shediac Road
MONCTON, New Brunswick E1A 2R6
Tel: (506) 855-2841
CH,CS

Nova Scotia

Hewlett-Packard (Canada) Ltd.
Suite 111
900 Windmill Road
DARTMOUTH, Nova Scotia B2Y 3Z6
Tel: (902) 469-7820
CH,CM,CS,E*,M,P*

Ontario

Hewlett-Packard (Canada) Ltd.
3325 N. Service Rd., Unit 6
BURLINGTON, Ontario P3A 2A3
Tel: (416) 335-8644
CS,M*
Hewlett-Packard (Canada) Ltd.
496 Days Road
KINGSTON, Ontario K7M 5R4
Tel: (613) 384-2088
CH,CS
Hewlett-Packard (Canada) Ltd.
552 Newbold Street
LONDON, Ontario N6E 2S5
Tel: (519) 686-9181
A,CH,CM,E*,M,P*
Hewlett-Packard (Canada) Ltd.
6877 Goreway Drive
MISSISSAUGA, Ontario L4V 1M8
Tel: (416) 678-9430
A,CH,CM,CS,E,M,P
Hewlett-Packard (Canada) Ltd.
2670 Queensview Dr.
OTTAWA, Ontario K2B 8K1
Tel: (613) 820-6483
A,CH,CM,CS,E*,MS,P*
Hewlett-Packard (Canada) Ltd.
1855 Lasalle Boulevard
SUDBURY, Ontario, P3A 2A3
Tel: (705) 560-5450
CH
Hewlett-Packard (Canada) Ltd.
220 Yorkland Blvd. Unit #11
WILLOWDALE, Ontario M2J 1R5
Tel: (416) 499-9333
CH
Quebec
Hewlett-Packard (Canada) Ltd.
17500 South Service Road
Trans-Canada Highway
KIRKLAND, Quebec H9J 2M5
Tel: (514) 697-4232
A,CH,CM,CS,E,M,P*
Hewlett-Packard (Canada) Ltd.
1150 Rue Claire Fontaine
QUEBEC CITY, Quebec G1R 5G4
Tel: (418) 648-0726
CH,CS
Hewlett-Packard (Canada) Ltd.
#7-130 Robin Crescent
SASKATOON, Saskatchewan S7L 6M7
Tel: (306) 242-3702
CH,CS
CHILE
ASC Ltda.
Austria 2041
SANTIAGO
Tel: 223-5946, 223-6148
Telex: 340192 ASC CK
P,C
Jorge Calcagni y Cia. Ltda.
Av. Italia 634 Santiago
Casilla 16475
SANTIAGO 9
Tel: 222-0222
Telex: 440283 JCYCL CZ
CM,E,M

Metrolab S.A.

Monjitas 454 of. 206
SANTIAGO
Tel: 395752, 398296
Telex: 340866 METLAB CK
A
Olympia (Chile) Ltda.
Av. Rodrigo de Araya 1045
Casilla 256-V
SANTIAGO 21
Tel: 225-5044
Telex: 340892 OLYMP
Cable: Olympiachile Santiagochile
CH,CS,P

CHINA, People's Republic of

China Hewlett-Packard Co., Ltd.
6th Floor, Sun Hung Kai Centre
30 Harbour Road
HONG KONG
Tel: 5-8323211
Telex: 36678 HEWPA HX
A,C,CH,CS,E,M,P
China Hewlett-Packard Rep. Office
P.O. Box 418
1A Lane 2, Luchang St.
Beiwei Rd., Xuanwu District
BEIJING
Tel: 33-1947, 33-7426
Telex: 22601 CTSHP CN
Cable: 1920
A,CH,CM,CS,E,P

COLOMBIA

InstrumentaciAO n
H. A. Langebaek & Kier S.A.
Carrera 4A No. 52A-26
Apartado Aereo 6287
BOGOTA 1, D.E.
Tel: 212-1466
Telex: 44400 INST CO
Cable: AARIS Bogota
CM,E,M
Nefromedicas Ltda.
Calle 123 No. 9B-31
Apartado Aereo 100-958
BOGOTA D.E., 10
Tel: 213-5267, 213-1615
Telex: 43415 HEGAS CO
A
Procesa, S.A.
CRA 7 No. 24-89 Piso 25
Torre Colpatría
Apartado Aereo No. 49667
BOGOTA D.E.
Tel: 2344925, 2344958, 2344742
Telex: 43127 COVER CO
C,P

Compumundo
Avenida 15 # 107-80
BOGOTA D.E.
Tel: 214-4458
Telex: 45466 MARICO
P

COSTA RICA

Científica Costarricense S.A.
Avenida 2, Calle 5
San Pedro de Montes de Oca
Apartado 10159
SAN JOSÉ
Tel: 24-38-20, 24-08-19
Telex: 2367 GALGUR CR
CM,E,M
CYPRUS
Telerexa Ltd.
P.O. Box 4809
14C Stassinou Avenue
NICOSIA
Tel: 62698
Telex: 2894 LEVIDO CY
E,M,P

DENMARK

Hewlett-Packard A/S
Datavej 52
DK-3460 **BIRKEROD**
Tel: (02) 81-66-40
Telex: 37409 hpas dk
A,CH,CM,CS,E,M,P
Hewlett-Packard A/S
Rolighedsvej 32
DK-8240 **RISSKOV**, Aarhus
Tel: (06) 17-60-00
Telex: 37409 hpas dk
CH,E

DOMINICAN REPUBLIC

Microprog S.A.
Juan Tomás Mejía y Cotes No. 60
Arroyo Hondo
SANTO DOMINGO
Tel: 565-6268
Telex: 4510 ARENTA DR (RCA)
P

ECUADOR

CYEDE Cia. Ltda.
Avenida Eloy Alfaro 1749
y Belgica
Casilla 6423 CCI
QUITO
Tel: 450-975, 243-052
Telex: 2548 CYEDE ED
CM,E,P
Hospitalar S.A.
Robles 625
Casilla 3590
QUITO
Tel: 545-250, 545-122
Telex: 2485 HOSPTL ED
Cable: HOSPITALAR-Quito
M
QUITO
Tel: 2-238-951
Telex: 2298 ECUAME ED

EGYPT

Egyptian International
Office for Foreign Trade
P.O. Box 2558
42 El-Zahraa Street
Dokki, CAIRO,
Tel: 712230
Telex: 93337 EGPOR UN
Cable: EGYPOR
P,A

EGYPT (Cont'd)

INFORMATIC FOR SYSTEMS

22 Talaat Harb Street
CAIRO,

Tel: 759006
Telex: 93697 SAFLM UN

CS
International Engineering Associates
24 Hussein Hegazi Street
Kasr-el-Aini

CAIRO,
Tel: 23829, 21641
Telex: 93830 IEA UN
Cable: INTEGASSO

E
S.S.C. Medical
40 Gezerat El Arab Street
Mohandessin
CAIRO,
Tel: 803844, 805998, 810263
Telex: 20503 SSC UN
M*

EL SALVADOR

IPESA de El Salvador S.A.
29 Avenida Norte 1216

SAN SALVADOR
Tel: 26-6858, 26-6868
Telex: 20539 IPESASAL
A,CH,CM,CS,E,P

FINLAND

Hewlett-Packard Oy
Piispankalliontie 17
02200 ESPOO
Tel: 00358-0-88721
Telex: 121563 HEWPA SF
CH,CM,SS,P

Hewlett-Packard Oy
(Olarinluoma 7)
PL 24
02101 ESPOO 10
Tel: (90) 4521022
A,E,M

Hewlett-Packard Oy
Aatoksenkatu 10-C
SF-40720-72 JYVASKYLA
Tel: (941) 216318
CH

Hewlett-Packard Oy
Kainvuntie 1-C
SF-90140-14 OULU
Tel: (981) 338785
CH

FRANCE

Hewlett-Packard France
Z.I. Mercure B
Rue Berthelot
F-13763 Les Milles Cedex
AIX-EN-PROVENCE
Tel: (42) 59-41-02
Telex: 410770F
A,CH,E,M,P*

Hewlett-Packard France
64, rue Marchand Saillant
F-61000 ALENCON
Tel: (33) 29 04 42

Hewlett-Packard France
Boite Postale 503
F-25026 BESANCON
28 rue de la Republique
F-25000 BESANCON
Tel: (81) 83-16-22
Telex: 361157
CH,M

Hewlett-Packard France
13, Place Napoleon III
F-29000 BREST
Tel: (98) 03-38-35
Hewlett-Packard France
Chemin des Mouilles
Boite Postale 162
F-69130 ECULLY Cedex (Lyon)
Tel: (78) 833-81-25
Telex: 310617F
A,CH,CS,E,M

Hewlett-Packard France
Parc d'Activite du Bois Briard
Ave. du Lac
F-91040 EVRY Cedex
Tel: 6 077-8383
Telex: 692315F
E

Hewlett-Packard France
5, Avenue Raymond Chanas
F-38320 EYBENS (Grenoble)
Tel: (76) 62-67-98
Telex: 980124 HP GRENOB EYBE
CH

Hewlett-Packard France
Centre d'Affaire Paris-Nord
Bâtiment Ampère 5 étage
Rue de la Commune de Paris
Boite Postale 300
F-93153 LE BLANC MESNIL
Tel: (1) 865-44-52
Telex: 211032F
CH,CS,E,M

Hewlett-Packard France
Parc d'Activités Cadera
Quartier Jean Mermoz
Avenue du Président JF Kennedy
F-33700 MERIGNAC (Bordeaux)
Tel: (56) 34-00-84
Telex: 550105F
CH,E,M

Hewlett-Packard France
Immuable "Les 3 B"
Nouveau Chemin de la Garde
ZAC de Bois Briard
F-44085 NANTES Cedex
Tel: (40) 50-32-22
Telex: 711085F
CH**

Hewlett-Packard France
125, rue du Faubourg Bannier
F-45000 ORLEANS
Tel: (38) 68 01 63

Hewlett-Packard France
Zone Industrielle de Courtaboeuf
Avenue des Tropiques
F-91947 Les Ulis Cedex ORSAY
Tel: (6) 907-78-25
Telex: 600048F
A,CH,CM,CS,E,M,P

Hewlett-Packard France
Paris Porte-Maillot
15, Avenue de L'Amiral Bruix
F-75782 PARIS CEDEX 16
Tel: (1) 502-12-20
Telex: 613663F
CH,M,P

Hewlett-Packard France
124, Boulevard Tourasse
F-64000 PAU
Tel: (59) 80 38 02

Hewlett-Packard France
2 AllAEE de la Bourgonnette
F-35100 RENNES
Tel: (99) 51-42-44
Telex: 740912F
CH,CM,E,M,P*

Hewlett-Packard France
98 Avenue de Bretagne
F-76100 ROUEN
Tel: (35) 63-57-66
Telex: 770035F
CH**,CS

Hewlett-Packard France
4 Rue Thomas Mann
Boite Postale 56
F-67033 STRASBOURG Cedex
Tel: (88) 28-56-46
Telex: 890141F
CH,E,M,P*

Hewlett-Packard France
Le PAEripole
20, Chemin du Pigeonnier de la
CAEpiGEere
F-31083 TOULOUSE Cedex
Tel: (61) 40-11-12
Telex: 531639F
A,CH,CS,E,P*

Hewlett-Packard France
9, rue Baudin
F-26000 VALENCE
Tel: (75) 42 76 16

Hewlett-Packard France
Carolor
ZAC de Bois Briard
F-57640 VIGY (Metz)
Tel: (8) 771 20 22
CH

Hewlett-Packard France
Immeuble PEricecentre
F-59658 VILLENEUVE D'ASCQ Cedex
Tel: (20) 91-41-25
Telex: 160124F
CH,E,M,P*

GERMAN FEDERAL REPUBLIC

Hewlett-Packard GmbH
Geschäftsstelle
Keithstrasse 2-4
D-1000 BERLIN 30
Tel: (030) 24-90-86
Telex: 018 3405 hpbln d
A,CH,E,M,P

Hewlett-Packard GmbH
Geschäftsstelle
Herrenberger Strasse 130
D-7030 BÖBLINGEN
Tel: (7031) 14-0
Telex: 07265739
A,CH,CM,CS,E,M,P

Hewlett-Packard GmbH
Geschäftsstelle
Emanuel-Leutze-Strasse 1
D-4000 DUSSELDORF
Tel: (0211) 5971-1
Telex: 085/86 533 hpdd d
A,CH,CS,E,M,P

Hewlett-Packard GmbH
Geschäftsstelle
Schleefstr. 28a
D-4600 DORTMUND-Aplerbeck
Tel: (0231) 45001

Hewlett-Packard GmbH
Vertriebszentrale Frankfurt
Berner Strasse 117
Postfach 560 140
D-6000 FRANKFURT 56
Tel: (0611) 50-04-1
Telex: 04 13249 hpffm d
A,CH,CM,CS,E,M,P

Hewlett-Packard GmbH
Geschäftsstelle
Aussenstelle Bad Homburg
Louisenstrasse 115
D-6380 BAD HOMBURG
Tel: (06172) 109-0

Hewlett-Packard GmbH
Geschäftsstelle
Kapstadtring 5
D-2000 HAMBURG 60
Tel: (040) 63804-1
Telex: 021 63 032 hphh d
A,CH,CS,E,M,P

Hewlett-Packard GmbH
Geschäftsstelle
Heidering 37-39
D-3000 HANNOVER 61
Tel: (0511) 5706-0
Telex: 092 3259
A,CH,CM,E,M,P

Hewlett-Packard GmbH
Geschäftsstelle
Rosslauer Weg 2-4
D-6800 MANNHEIM
Tel: (0621) 70050
Telex: 0462105
A,C,E

Hewlett-Packard GmbH
Geschäftsstelle
Messerschmittstrasse 7
D-7910 NEU ULM
Tel: 0731-70241
Telex: 0712816 HP ULM-D
A,C,E*

Hewlett-Packard GmbH
Geschäftsstelle
Ehlicherstr. 13
D-8500 NÜRNBERG 10
Tel: (0911) 5205-0
Telex: 0623 860
CH,CM,E,M,P

Hewlett-Packard GmbH
Geschäftsstelle
Eschenstrasse 5
D-8028 TAUFKIRCHEN
Tel: (089) 6117-1
Telex: 0524985
A,CH,CM,E,M,P

GREAT BRITAIN
See United Kingdom



SALES & SUPPORT OFFICES

Arranged alphabetically by country

GREECE

Hewlett-Packard A.E.
178, Kifissias Avenue
6th Floor
Halandri-ATHENS
Greece
Tel: 6471673, 6471543, 6472971
A,CH,CM**,CS**,E,M,P

Kostas Karayannis S.A.
8 Omirou Street
ATHENS 133
Tel: 32 30 303, 32 37 371
Telex: 215962 RKAR GR
A,CH,CM,CS,E,M,P

PLAISIO S.A.
Eliopoulos Brohers Ltd.
11854

ATHENS

Tel: 34-51-911
Telex: 216286
P

GUATEMALA

IPESA
Avenida Reforma 3-48, Zona 9
GUATEMALA CITY
Tel: 316627, 314786
Telex: 4192 TELTRO GU
A,CH,CM,CS,E,M,P

HONG KONG

Hewlett-Packard Hong Kong, Ltd.
G.P.O. Box 795
5th Floor, Sun Hung Kai Centre
30 Harbour Road
HONG KONG
Tel: 5-8323211
Telex: 66678 HEWPA HX
Cable: HEWPACK HONG KONG
E,CH,CS,P

CET Ltd.

10th Floor, Hua Asia
Bldg. Gloucester
64-66 Gloucester Road

HONG KONG

Tel: (5) 200922
Telex: 85148 CET HX
CM

Schmidt & Co. (Hong Kong) Ltd.
18th Floor, Great Eagle Centre
23 Harbour Road, Wanchai

HONG KONG

Tel: 5-8330222
Telex: 74766 SCHMC HX
A,M

ICELAND

Elding Trading Company Inc.
Hafnarnvoli-Tryggvagotu
P.O. Box 895
IS-REYKJAVIK
Tel: 1-58-20, 1-63-03
M

INDIA

Computer products are sold through
Blue Star Ltd. All computer repairs and
maintenance service is done through
Computer Maintenance Corp.

Blue Star Ltd.
Sabri Complex II Floor
24 Residency Rd.

BANGALORE 560 025
Tel: 55660
Telex: 0845-430
Cable: BLUESTAR
A,CH*,CM,CS*,E

Blue Star Ltd.
Band Box House
Prabhadevi

BOMBAY 400 025
Tel: 422-3101
Telex: 011-3751
Cable: BLUESTAR
A,M

Blue Star Ltd.

Sahas
414/2 Vir Savarkar Marg
Prabhadevi

BOMBAY 400 025
Tel: 422-6155
Telex: 011-71193

Cable: FROSTBLUE
A,CH*,CM,CS*,E,M

Blue Star Ltd.
Kalyan, 19 Vishwas Colony
Alkapuri, BORODA, 390 005
Tel: 65235
Cable: BLUE STAR
A

Blue Star Ltd.
7 Hare Street
CALCUTTA 700 001

Tel: 12-01-31
Telex: 021-7655
Cable: BLUESTAR
A,M

Blue Star Ltd.
133 Kodambakkam High Road
MADRAS 600 034

Tel: 82057
Telex: 041-379
Cable: BLUESTAR
A,M

Blue Star Ltd.
Bhandari House, 7th/8th Floors
91 Nehru Place

NEW DELHI 110 024
Tel: 682547
Telex: 031-2463

Cable: BLUESTAR
A,CH*,CM,CS*,E,M

Blue Star Ltd.
15/16:C Wellesley Rd.

PUNE 411 011
Tel: 22775
Cable: BLUE STAR
A

Blue Star Ltd.
2-2-47/1108 Bolarum Rd.

SECUNDERABAD 500 003
Tel: 72057
Telex: 0155-459
Cable: BLUEFROST
A,E

Blue Star Ltd.
T.C. 7/603 Poornima
Maruthankuzhi
TRIVANDRUM 695 013
Tel: 65799
Telex: 0884-259
Cable: BLUESTAR
E

Computer Maintenance Corporation Ltd.
115, Sarojini Devi Road
SECUNDERABAD 500 003
Tel: 310-184, 345-774
Telex: 031-2960
CH**

INDONESIA

BERCA Indonesia P.T.
P.O.Box 496/Jkt.
Jl. Abdul Muis 62
JAKARTA
Tel: 21-373009
Telex: 46748 BERSAL IA
Cable: BERSAL JAKARTA
P

BERCA Indonesia P.T.
P.O.Box 2497/Jkt
Antara Bldg., 17th Floor
Jl. Medan Merdeka Selatan 17

JAKARTA-PUSAT

Tel: 21-344-181
Telex: BERSAL IA
A,CS,E,M

BERCA Indonesia P.T.
P.O. Box 174/SBY.

Jl. Kutei No. 11
SURABAYA
Tel: 68172
Telex: 31146 BERSAL SB
Cable: BERSAL-SURABAYA
A*,E,M,P

IRAQ

Hewlett-Packard Trading S.A.
Service Operation
Al Mansoor City 9B/3/7
BAGHDAD
Tel: 551-49-73
Telex: 212-455 HEPAIRAQ IK
CH,CS

IRELAND

Hewlett-Packard Ireland Ltd.
82/83 Lower Leeson Street

DUBLIN 2
Tel: 0001 608800
Telex: 30439

A,CH,CM,CS,E,M,P
Cardiac Services Ltd.
Kilmore Road

Artane
DUBLIN 5
Tel: (01) 351820

Telex: 30439
M

ISRAEL

Eldan Electronic Instrument Ltd.
P.O.Box 1270
JERUSALEM 91000
16, Ohaliav St.
JERUSALEM 94467
Tel: 533 221, 553 242
Telex: 25231 AB/PAKRD IL
A,M

Computation and Measurement
Systems (CMS) Ltd.
11 Masad Street
67060

TEL-AVIV

Tel: 388 388
Telex: 33569 Motil IL
CH,CM,CS,E,P

ITALY

Hewlett-Packard Italiana S.p.A.
Traversa 99C
Via Giulio Petroni, 19
I-70124 BARI
Tel: (080) 41-07-44
M,CH

Hewlett-Packard Italiana S.p.A.
Via Martin Luther King, 38/III
I-40132 BOLOGNA
Tel: (051) 402394
Telex: 511630
CH,CS,E,M

Hewlett-Packard Italiana S.p.A.
Via Principe Nicola 43G/C
I-95126 CATANIA
Tel: (095) 37-10-87
Telex: 970291
CH

Hewlett-Packard Italiana S.p.A.
Via G. Di Vittorio 9
I-20063 CERNUSCO SUL
NAVIGLIO

(Milano)
Tel: (02) 923691
Telex: 334632

A,CH,CM,CS,E,M,P

Hewlett-Packard Italiana S.p.A.
Via C. Colombo 49
I-20090 TREZZANO SUL

NAVIGLIO
(Milano)

Tel: (02) 4459041
Telex: 322116

CH,CS
Hewlett-Packard Italiana S.p.A.
Via Nuova San Rocco a

Capodimonte, 62/A
I-80131 NAPOLI

Tel: (081) 7413544

Telex: 710698

A**,CH,CS,E,M

Hewlett-Packard Italiana S.p.A.
Viale G. Modugno 33
I-16156 GENOVA PEGLI

Tel: (010) 68-37-07

Telex: 215238

E,C

Hewlett-Packard Italiana S.p.A.
Via Pelizzo 15
I-35128 PADOVA

Tel: (049) 664888

Telex: 430315

A,CH,CS,E,M

Hewlett-Packard Italiana S.p.A.
Viale C. Pavese 340
I-00144 ROMA EUR

Tel: (06) 54831

Telex: 610514

A,CH,CS,E,M,P*

ITALY (Cont'd)

Hewlett-Packard Italiana S.p.A.
Via di Casellina 57/C
I-50018 **SCANDICCI-FIRENZE**
Tel: (055) 753863
CH,E,M

Hewlett-Packard Italiana S.p.A.
Corso Svizzera, 185
I-10144 **TORINO**
Tel: (011) 74 4044
Telex: 221079
A*,CS,CH,E

JAPAN

Yokogawa-Hewlett-Packard Ltd.
152-1, Onna

ATSUGI, Kanagawa, 243
Tel: (0462) 28-0451
CM,C*,E

Yokogawa-Hewlett-Packard Ltd.
Meiji-Seimei Bldg. 6F
3-1 Hon Chiba-Cho
CHIBA, 280
Tel: 472 25 7701
E,CH,CS

Yokogawa-Hewlett-Packard Ltd.
Yasuda-Seimei Hiroshima Bldg.
6-11, Hon-dori, Naka-ku
HIROSHIMA, 730
Tel: 82-241-0611

Yokogawa-Hewlett-Packard Ltd.
Towa Building
2-3, Kaigan-dori, 2 Chome Chuo-ku
KOBE, 650
Tel: (078) 392-4791
C,E

Yokogawa-Hewlett-Packard Ltd.
Kumagaya Asahi 82 Bldg
3-4 Tsukuba
KUMAGAYA, Saitama 360
Tel: (0485) 24-6563
CH,CM,E

Yokogawa-Hewlett-Packard Ltd.
Asahi Shinbun Daiichi Seimei Bldg.
4-7, Hanabata-cho
KUMAMOTO, 860
Tel: (0963) 54-7311
CH,E

Yokogawa-Hewlett-Packard Ltd.
Shin-Kyoto Center Bldg.
614, Higashi-Shiokoji-cho
Karasuma-Nishiiru
Shiokoji-dori, Shimogyo-ku
KYOTO, 600
Tel: 075-343-0921
CH,E

Yokogawa-Hewlett-Packard Ltd.
Mito Mitsui Bldg
4-73, Sanno-maru, 1 Chome
MITO, Ibaraki 310
Tel: (0292) 25-7470
CH,CM,E

Yokogawa-Hewlett-Packard Ltd.
Meiji-Seimei Kokubun Bldg. 7-8
Kokubun, 1 Chome, Sendai
MIYAGI, 980
Tel: (0222) 25-1011
Telex:
C,E

Yokogawa-Hewlett-Packard Ltd.
Sumitomo Seimei 14-9 Bldg.
Meieki-Minami, 2 Chome
Nakamura-ku
NAGOYA, 450
Tel: (052) 571-5171
CH,CM,CS,E,M

Yokogawa-Hewlett-Packard Ltd.
Chuo Bldg.,
4-20 Nishinakajima, 5 Chome
Yodogawa-ku
OSAKA, 532
Tel: (06) 304-6021
Telex: YHPOSA 523-3624
A,CH,CM,CS,E,M,P*

Yokogawa-Hewlett-Packard Ltd.
27-15, Yabe, 1 Chome
SAGAMIHARA Kanagawa, 229
Tel: 0427 59-1311

Yokogawa-Hewlett-Packard Ltd.
Daiichi Seimei Bldg.
7-1, Nishi Shinjuku, 2 Chome
Shinjuku-ku, **TOKYO** 160
Tel: 03-348-4611
CH,E

Yokogawa-Hewlett-Packard Ltd.
29-21 Takaido-Higashi, 3 Chome
Suginami-ku **TOKYO** 168
Tel: (03) 331-6111
Telex: 232-2024 YHPTOK
A,CH,CM,CS,E,M,P*

Yokogawa-Hewlett-Packard Ltd.
Daiichi Asano Building
2-8, Odori, 5 Chome
UTSUNOMIYA, Tochigi 320
Tel: (0286) 25-7155
CH,CS,E

Yokogawa-Hewlett-Packard Ltd.
Yasuda Seimei Nishiguchi Bldg.
30-4 Tsuruya-cho, 3 Chome
YOKOHAMA 221
Tel: (045) 312-1252
CH,CM,E

JORDAN

Scientific and Medical Supplies Co.
P.O. Box 1387

AMMAN

Tel: 24907, 39907
Telex: 21456 SABCO JO
CH,E,M,P

KENYA

ADCOM Ltd., Inc., Kenya
P.O.Box 30070

NAIROBI

Tel: 331955
Telex: 22639
E,M

KOREA

Samsung Hewlett-Packard Co. Ltd.
12 Fl. Kinam Bldg.
San 75-31, Yeoksam-Dong
Kangnam-Ku
Yeongdong P.O. Box 72
SEOUL
Tel: 555-7555, 555-5447
Telex: K27364 SAMSAN
A,CH,CM,CS,E,M,P

KUWAIT

Al-Khaldiya Trading & Contracting
P.O. Box 830

SAFAT

Tel: 424910, 411726
Telex: 22481 AREEG KT
Cable: *VISCOUNT*
E,M,A

Photo & Cine Equipment
P.O. Box 270

SAFAT

Tel: 2445111
Telex: 22247 MATIN KT
Cable: *MATIN KUWAIT*
P

W.J. Towell Computer Services
P.O. Box 75

SAFAT

Tel: 2462640/1
Telex: 30336 TOWELL KT
C

LEBANON

Computer Information Systems
P.O. Box 11-6274

BEIRUT

Tel: 89 40 73
Telex: 42309
C,E,M,P

LUXEMBOURG

Hewlett-Packard Belgium S.A./N.V.
Blvd de la Woluwe, 100
Woluwedal
B-1200 **BRUSSELS**
Tel: (02) 762-32-00
Telex: 23-494 paloben bru
A,CH,CM,CS,E,M,P

MALAYSIA

Hewlett-Packard Sales (Malaysia)
Sdn. Bhd.
1st Floor, Bangunan British
American
Jalan Semantan, Damansara Heights
KUALA LUMPUR 23-03

Tel: 943022

Telex: MA31011
A,CH,E,M,P*

Protel Engineering

P.O.Box 1917
Lot 6624, Section 64
23/4 Pending Road
Kuching, **SARAWAK**
Tel: 36299

Telex: MA 70904 PROMAL
Cable: PROTELENG
A,E,M

MALTA

Philip Toledo Ltd.
Notabile Rd.
MRIEHEL
Tel: 447 47, 455 66
Telex: Media MW 649
E,P,M

MEXICO

Hewlett-Packard Mexicana, S.A.
de C.V.
Av. Periferico Sur No. 6501
Tepepan, Xochimilco
16020 **MEXICO D.F.**
Tel: 6-76-46-00
Telex: 17-74-507 HEWPACK MEX
A,CH,CS,E,M,P

Hewlett-Packard Mexicana, S.A.
de C.V.
Czda. del Valle
409 Ote. 1 °Piso
Colonia del Valle
Municipio de Garza Garcia
66220 **MONTERREY**, Nuevo LeAOn
Tel: 78 42 41
Telex: 038 410
CH

Equipos Cientificos de Occidente, S.A.
Av. Lazaro Cardenas 3540

GUADALAJARA

Tel: 21-66-91
Telex: 0684186 ECOME
A

Infograficas y Sistemas del Noreste, S.A.
Rio Orinoco #171 Oriente

Despacho 2001
Colonia Del Valle
MONTERREY

Tel: 782499, 781259A

A

MOROCCO

Dolbeau
81 rue Karatchi
CASABLANCA
Tel: 3041-82, 3068-38
Telex: 23051, 22822
E

Gerep

2 rue d'Agadir
Boite Postale 156
CASABLANCA
Tel: 272093, 272095
Telex: 23 739
P

Sema-Maroc
Rue Lapebie
CASABLANCA
Tel: 26.09.80
CH,CS,P

NETHERLANDS

Hewlett-Packard Nederland B.V.
Van Heuven Goedhartlaan 121
NL 1181KK **AMSTELVEEN**
P.O. Box 667
NL 1180 AR **AMSTELVEEN**
Tel: (020) 47-20-21
Telex: 13 216 HEPAC NL
A,CH,CM,CS,E,M,P

Hewlett-Packard Nederland B.V.
Bongerd 2
NL 2906VK **CAPELLE A/D IJSSEL**
P.O. Box 41
NL 2900AA **CAPELLE A/D IJSSEL**
Tel: (10) 51-64-44
Telex: 12161 HEPAC NL
A,CH,CS,E

Hewlett-Packard Nederland B.V.
Pastoor Petersstraat 134-136
NL 5612 LV **EINDHOVEN**
P.O. Box 2342
NL 5600 CH **EINDHOVEN**
Tel: (040) 326911
Telex: 51484 hepae nl
A,CH** ,E,M

SALES & SUPPORT OFFICES

Arranged alphabetically by country

NEW ZEALAND

Hewlett-Packard (N.Z.) Ltd.
5 Owens Road
P.O. Box 26-189
Epsom, **AUCKLAND**
Tel: 687-159
Cable: HEWPAK Auckland
CH,CS,CM,E,P*

Hewlett-Packard (N.Z.) Ltd.
4-12 Cruickshank Street
Kilbirnie, **WELLINGTON 3**
P.O. Box 9443
Courtenay Place, **WELLINGTON 3**
Tel: 877-199
Cable: HEWPACK Wellington
CH,CS,CM,E,P

Northrop Instruments & Systems Ltd.
369 Khyber Pass Road
P.O. Box 8602

AUCKLAND
Tel: 794-091
Telex: 60605
A,M

Northrop Instruments & Systems Ltd.
110 Mandeville St.
P.O. Box 8388

CHRISTCHURCH
Tel: 488-873
Telex: 4203
A,M

Northrop Instruments & Systems Ltd.
Sturdee House
85-87 Ghuznee Street
P.O. Box 2406

WELLINGTON
Tel: 850-091
Telex: NZ 3380
A,M

NORTHERN IRELAND

See United Kingdom

NORWAY

Hewlett-Packard Norge A/S
Folke Bernadottes vei 50
P.O. Box 3558
N-5033 **FYLLINGSDALEN** (Bergen)
Tel: 0047/5/16 55 40
Telex: 16621 hpnas n
CH,CS,E,M

Hewlett-Packard Norge A/S
UCOsterndalen 16-18
P.O. Box 34
N-1345 **OCUSTERÅS**
Tel: 0047/2/17 11 80
Telex: 16621 hpnas n
A,CH,CM,CS,E,M,P

OMAN

Khimjil Ramdas
P.O. Box 19

MUSCAT

Tel: 722225, 745601
Telex: 3289 BROKER MB MUSCAT
P

Suhail & Saud Bahwan
P.O. Box 169

MUSCAT

Tel: 734 201-3
Telex: 3274 BAHWAN MB
E

Imtac LLC
P.O. Box 8676

MUTRAH

Tel: 601695
Telex: 5741 Tawoos On
A,C,M

PAKISTAN

Mushko & Company Ltd.
House No. 16, Street No. 16
Sector F-6/3
ISLAMABAD
Tel: 824545
Cable: FEMUS Islamabad
A,E,M,P*

Mushko & Company Ltd.
Oosman Chambers
Abdullah Haroon Road
KARACHI 0302
Tel: 524131, 524132
Telex: 2894 MUSKO PK
Cable: COOPERATOR Karachi
A,E,M,P*

PANAMA

ElectrOnico Balboa, S.A.
Calle Samuel Lewis, Ed. Alfa
Apartado 4929

PANAMA 5
Tel: 63-6613, 63-6748
Telex: 3483 ELECTRON PG
A,CM,E,M,P

PERU

Cía Electro Médica S.A.
Los Flamencos 145, San Isidro
Casilla 1030
LIMA 1
Tel: 41-4325, 41-3703
Telex: Pub. Booth 25306
CM,E,M,P

SAMS

Rio De La Plata 305
SAN ISIDRO
Tel: 419928
Telex: 394 20450 PELIBERTAD
P

PHILIPPINES

The Online Advanced Systems
Corporation
Rico House, Amorsolo Cor. Herrera
Street
Legaspi Village, Makati
P.O. Box 1510

Metro **MANILA**
Tel: 815-38-11 (up to 16)
Telex: 63274 Online PN
A,CH,CS,E,M

Electronic Specialists and
Proponents Inc.
690-B Epifanio de los Santos
Avenue
Cubao, **QUEZON CITY**
P.O. Box 2649 Manila
Tel: 98-96-81, 98-96-82, 98-96-83
Telex: 40018, 42000 ITT GLOBE MAC-
KAY BOOTH
P

PORTUGAL

Mundinter
Intercambio Mundial de ComAErcio
S.A.R.L.
P.O. Box 2761
Av. Antonio Augusto de Aguiar 138

P-LISBON
Tel: (19) 53-21-31, 53-21-37
Telex: 16691 munter p
M

Soquimica
Av. da Liberdade, 220-2
1298 **LISBOA** Codex
Tel: 56 21 81/2/3
Telex: 13316 SABASA
P

Telectra-Empresa Técnica de
Equipmentos Eléctricos S.A.R.L.
Rua Rodrigo da Fonseca 103
P.O. Box 2531

P-LISBON 1
Tel: (19) 68-60-72
Telex: 12598
CM,E

Rarcentro Ltda
R. Costa Cabral 575
4200 **PORTO**
Tel: 499174/495173
Telex: 26054
CH,CS

PUERTO RICO

Hewlett-Packard Puerto Rico
101 MuAnoz Rivera Av
Esu. Calle Ochoa
HATO REY, Puerto Rico 00918
Tel: (809) 754-7800
A,CH,CS,CM,M,E,P

QATAR

Computer Arabia
P.O. Box 2750

DOHA
Tel: 883555
Telex: 4806 CHPARB
P

Nasser Trading & Contracting
P.O. Box 1563

DOHA

Tel: 422170
Telex: 4439 NASSER DH
M

SAUDI ARABIA

Modern Electronic Establishment
Hewlett-Packard Division
P.O. Box 281
Thuobah

AL-KHOBAR
Tel: 895-1760, 895-1764
Telex: 671 106 HPMEEK SJ
Cable: ELECTA AL-KHOBAR
CH,CS,E,M

Modern Electronic Establishment
Hewlett-Packard Division
P.O. Box 1228

Redec Plaza, 6th Floor

JEDDAH

Tel: 644 38 48
Telex: 4027 12 FARNAS SJ
Cable: ELECTA JEDDAH
A,CH,CS,CM,E,M,P

Modern Electronic Establishment
Hewlett-Packard Division
P.O. Box 22015

RIYADH

Tel: 491-97 15, 491-63 87
Telex: 202049 MEERYD SJ
CH,CS,E,M

Abdul Ghani El Ajou
P.O. Box 78

RIYADH

Tel: 40 41 717
Telex: 200 932 EL AJOU
P

SCOTLAND

See United Kingdom

SINGAPORE

Hewlett-Packard Singapore (Sales)
Pte. Ltd.
#08-00 Inchcape House
450-2 Alexandra Road
P.O. Box 58 Alexandra Rd. Post
Office
SINGAPORE, 9115
Tel: 631788
Telex: HPSGSO RS 34209
Cable: HEWPACK, Singapore
A,CH,CS,E,MS,P

Dynamar International Ltd.
Unit 05-11Block 6
Kolam Ayer Industrial Estate

SINGAPORE 1334
Tel: 747-6188
Telex: RS 26283
CM



SOUTH AFRICA (Cont'd)

Hewlett-Packard So Africa (Pty.) Ltd.
Private Bag Wendywood
SANDTON 2144
Tel: 802-5111, 802-5125
Telex: 4-20877
Cable: HEWPACK Johannesburg
A,CH,CM,CS,E,M,P

SPAIN

Hewlett-Packard Española S.A.
Calle Entenza, 321
E-BARCELONA 29
Tel: 322.24.51, 321.73.54
Telex: 52603 hpbee
A,CH,CS,E,M,P

Hewlett-Packard Española S.A.
Calle San Vicente S/No
Edificio Albia II 7B
E-BILBAO 1
Tel: 423.83.06
A,CH,E,M

Hewlett-Packard Española S.A.
Ctra. de la Coruña, Km. 16, 400
Las Rozas
E-MADRID
Tel: (1) 637.00.11
Telex: 23515 HPE
CH,CS,M

Hewlett-Packard Española S.A.
Avda. S. Francisco Javier, S/no
Planta 10. Edificio Sevilla 2,
E-SEVILLA 5
Tel: 64.44.54
Telex: 72933
A,CS,M,P

Hewlett-Packard Española S.A.
C/Isabel La Católica, 8
E-46004 VALENCIA
Tel: 0034/6/351 59 44
CH,P

SWEDEN

Hewlett-Packard Sverige AB
Sunnanvagen 14K
S-22226 **LUND**
Tel: (046) 13-69-79
Telex: (854) 17886 (via Spånga office)
CH

Hewlett-Packard Sverige AB
Östra Tullgatan 3
S-21128 **MALMÖ**
Tel: (040) 70270
Telex: (854) 17886 (via Spånga office)
CH

Hewlett-Packard Sverige AB
Västra Vintergatan 9
S-70344 **ÖREBRO**
Tel: (19) 10-48-80
Telex: (854) 17886 (via Spånga office)
CH

Hewlett-Packard Sverige AB
Skalholtsgatan 9, Kista
Box 19
S-16393 **SPÅNGA**
Tel: (08) 750-2000
Telex: (854) 17886
Telefax: (08) 7527781
A,CH,CM,CS,E,M,P

Hewlett-Packard Sverige AB
Frötällsgatan 30
S-42132 **VÄSTRA-FRÖLUNDA**
Tel: (031) 49-09-50
Telex: (854) 17886 (via Spånga office)
CH,E,P

SWITZERLAND

Hewlett-Packard (Schweiz) AG
Clarastrasse 12
CH-4058 **BASEL**
Tel: (61) 33-59-20
A

Hewlett-Packard (Schweiz) AG
7, rue du Bois-du-Lan
Case Postale 365
CH-1217 **MEYRIN 2**
Tel: (0041) 22-83-11-11
Telex: 27333 HPAG CH
CH,CM,CS

Hewlett-Packard (Schweiz) AG
Allmend 2
CH-8967 **WIDEN**
Tel: (0041) 57 31 21 11
Telex: 53933 hpag ch
Cable: HPAG CH
A,CH,CM,CS,E,M,P

SYRIA

General Electronic Inc.
Nuri Basha Ahnaf Ebn Kays Street
P.O. Box 5781
DAMASCUS
Tel: 33-24-87
Telex: 411 215
Cable: ELECTROBOR DAMASCUS
E

Middle East Electronics
P.O.Box 2308
Abu Rumnanah
DAMASCUS
Tel: 33 45 92
Telex: 411 304
M

TAIWAN

Hewlett-Packard Taiwan
Kaohsiung Office
11/F 456, Chung Hsiao 1st Road
KAOHSIUNG
Tel: (07) 2412318
CH,CS,E

Hewlett-Packard Taiwan
8th Floor Hewlett-Packard Building
337 Fu Hsing North Road
TAIPEI
Tel: (02) 712-0404
Telex: 24439 HEWPACK
Cable: HEWPACK Taipei
A,CH,CM,CS,E,M,P
Ing Lih Trading Co.
3rd Floor, 7 Jen-Ai Road, Sec. 2
TAIPEI 100
Tel: (02) 3948191
Cable: INGLIH TAIPEI
A

THAILAND

Unimesa
30 Patpong Ave., Suriwong
BANGKOK 5
Tel: 235-5727
Telex: 84439 Simonco TH
Cable: UNIMESA Bangkok
A,CH,CS,E,M
Bangkok Business Equipment Ltd.
5/5-6 Dejo Road
BANGKOK
Tel: 234-8670, 234-8671
Telex: 87669-BEQUIPT TH
Cable: BUSIQUIPT Bangkok
P

TOGO

Societe Africaine De
Promotion
B.P. 12271
LOME
Tel: 21-62-88
Telex: 5304
P

TRINIDAD & TOBAGO

Caribbean Telecoms Ltd.
Corner McAllister Street &
Eastern Main Road, Laventille
P.O. Box 732
PORT-OF-SPAIN
Tel: 624-4213
Telex: 22561 CARTEL WG
Cable: CARTEL, PORT OF SPAIN
CM,E,M,P
Computer and Controls Ltd.
P.O. Box 51
66 Independence Square
PORT-OF-SPAIN
Tel: 623-4472
Telex: 3000 POSTLX WG
P

TUNISIA

Tunisie Electronique
31 Avenue de la Liberte
TUNIS
Tel: 280-144
CH,CS,E,P
Corema
1 ter. Av. de Carthage
TUNIS
Tel: 253-821
Telex: 12319 CABAM TN
M

TURKEY

E.M.A
Mediha Eldem Sokak No. 41/6
Yenisehir
ANKARA
Tel: 319175
Telex: 42321 KTX TR
Cable: EMATRADE ANKARA
M
Kurt & Kurt A.S.
Mithatpasa Caddesi No. 75
Kat 4 Kizilay
ANKARA
Tel: 318875/6/7/8
Telex: 42490 MESR TR
A

Saniva Bilgisayar Sistemleri A.S.
Buyukdere Caddesi 103/6
Gayrettepe
ISTANBUL
Tel: 1673180
Telex: 26345 SANI TR
C,P

Teknim Company Ltd.
Iran Caddesi No. 7
Kavaklidere
ANKARA
Tel: 275800
Telex: 42155 TKNM TR
E,CM

UNITED ARAB

EMIRATES

Emitac Ltd.
P.O. Box 1641
SHARJAH,
Tel: 591181
Telex: 68136 EMITAC EM
Cable: EMITAC SHARJAH
E,C,M,P,A

Emitac Ltd.
P.O. Box 2711

ABU DHABI,
Tel: 820419-20
Cable: EMITACH ABUDHABI

Emitac Ltd.
P.O. Box 8391

DUBAI,
Tel: 377951

Emitac Ltd.
P.O. Box 473

RAS AL KHAMAH,
Tel: 28133, 21270

UNITED KINGDOM

GREAT BRITAIN

Hewlett-Packard Ltd.
Trafalgar House
Navigation Road
ALTRINCHAM
Cheshire WA14 1NU
Tel: 061 928 6422
Telex: 668068
A,CH,CS,E,M,M,P
Hewlett-Packard Ltd.
Miller House
The Ring, **BRACKNELL**
Berks RG12 1XN
Tel: 44344 424898
Telex: 848733
E

Hewlett-Packard Ltd.
Elstree House, Elstree Way
BOREHAMWOOD, Herts WD6 1SG
Tel: 01 207 5000
Telex: 8952716
E,CH,CS,P

Hewlett-Packard Ltd.
Oakfield House, Oakfield Grove
Clifton **BRISTOL,** Avon BS8 2BN
Tel: 0272 736806
Telex: 444302
CH,CS,E,P



SALES & SUPPORT OFFICES

Arranged alphabetically by country

GREAT BRITAIN (Cont'd)

Hewlett-Packard Ltd.
Bridewell House
Bridewell Place
LONDON EC4V 6BS
Tel: 01 583 6565
Telex: 298163
CH,CS,P

Hewlett-Packard Ltd.
Fourier House
257-263 High Street
LONDON COLNEY
Herts. AL2 1HA, St. Albans
Tel: 0727 24400
Telex: 1-8952716
CH,CS

Hewlett-Packard Ltd.
Pontefract Road
NORMANTON, West Yorkshire WF6 1RN
Tel: 0924 895666
Telex: 557355
CH,CS,P

Hewlett-Packard Ltd.
The Quadrangle
106-118 Station Road
REDHILL, Surrey RH1 1PS
Tel: 0737 68655
Telex: 947234
CH,CS,E,P

Hewlett-Packard Ltd.
Avon House
435 Stratford Road
Shirley, SOLIHULL, West Midlands
B90 4BL
Tel: 021 745 8800
Telex: 339105
CH,CS,E,P

Hewlett-Packard Ltd.
West End House
41 High Street, West End
SOUTHAMPTON
Hampshire SO3 3DQ
Tel: 04218 6767
Telex: 477138
CH,CS,P

Hewlett-Packard Ltd.
King Street Lane
Winnersh, WOKINGHAM
Berkshire RG11 5AR
Tel: 0734 784774
Telex: 847178
A,CH,CS,E,M,P

Hewlett-Packard Ltd.
Nine Mile Ride
Easthampstead, WOKINGHAM
Berkshire, 3RG 11 3LL
Tel: 0344 773100
Telex: 848805
CH,CS,E,P

IRELAND

NORTHERN IRELAND

Hewlett-Packard Ltd.
Cardiac Services Building
95A Finaghy Road South
BELFAST BT10 0BY
Tel: 0232 625-566
Telex: 747626
CH,CS

SCOTLAND

Hewlett-Packard Ltd.
SOUTH QUEENSFERRY
West Lothian, EH30 9TG
Tel: 031 331 1188
Telex: 72682
CH,CM,CS,E,M,P

UNITED STATES

Alabama

Hewlett-Packard Co.
700 Century Park South, Suite 128
BIRMINGHAM, AL 35226
Tel: (205) 822-6802
C,CH,CS,P*

Hewlett-Packard Co.
420 Wynn Drive
P.O. Box 7700
HUNTSVILLE, AL 35807
Tel: (205) 830-2000
C,CH,CM,CS,E,M*

Alaska

Hewlett-Packard Co.
3601 C St., Suite 1234
ANCHORAGE, AK 99504
Tel: (907) 563-8855
CH,CS,E

Arizona

Hewlett-Packard Co.
8080 Pointe Parkway West
PHOENIX, AZ 85044
Tel: (602) 273-8000
A,CH,CM,CS,E,M

Hewlett-Packard Co.
2424 East Aragon Road
TUCSON, AZ 85706
Tel: (602) 573-7400
CH,E,M**

California

Hewlett-Packard Co.
99 South Hill Dr.
BRISBANE, CA 94005
Tel: (415) 330-2500
CH,CS

Hewlett-Packard Co.
P.O. Box 7830 (93747)
5060 E. Clinton Avenue, Suite 102
FRESNO, CA 93727
Tel: (209) 252-9652
CH,CS,M

Hewlett-Packard Co.
1421 S. Manhattan Av.
FULLERTON, CA 92631
Tel: (714) 999-6700
CH,CM,CS,E,M

Hewlett-Packard Co.
320 S. Kellogg, Suite B
GOLETA, CA 93117
Tel: (805) 967-3405
CH

Hewlett-Packard Co.
5400 W. Rosecrans Blvd.
LAWDALE, CA 90260
P.O. Box 92105
LOS ANGELES, CA 90009
Tel: (213) 643-7500
Telex: 910-325-6608
CH,CM,CS,M

Hewlett-Packard Co.
3155 Porter Drive
PALO ALTO, CA 94304
Tel: (415) 857-8000
CH,CS,E

Hewlett-Packard Co.
4244 So. Market Court, Suite A
P.O. Box 15976
SACRAMENTO, CA 95813
Tel: (916) 929-7222
A*,CH,CS,E,M

Hewlett-Packard Co.
9606 Aero Drive
P.O. Box 23333
SAN DIEGO, CA 92123
Tel: (619) 279-3200
CH,CM,CS,E,M

Hewlett-Packard Co.
2305 Camino Ramon 'C'
SAN RAMON, CA 94583
Tel: (415) 838-5900
CH,CS

Hewlett-Packard Co.
3005 Scott Boulevard
SANTA CLARA, CA 95050
Tel: (408) 988-7000
Telex: 910-338-0586
A,CH,CM,CS,E,M

Hewlett-Packard Co.
5703 Corsa Avenue
WESTLAKE VILLAGE, CA 91362
Tel: (213) 706-6800
E*,CH*,CS*

Colorado

Hewlett-Packard Co.
24 Inverness Place, East
ENGLEWOOD, CO 80112
Tel: (303) 649-5000
A,CH,CM,CS,E,M

Hewlett-Packard Co.
Eff. Dec. 1, 1984
500 Sylvan Av.
BRIDGEPORT, CT 06606
Tel: (203) 371-6454
CH,CS,E

Hewlett-Packard Co.
47 Barnes Industrial Road South
P.O. Box 5007
WALLINGFORD, CT 06492
Tel: (203) 265-7801
A,CH,CM,CS,E,M

Florida

Hewlett-Packard Co.
2901 N.W. 62nd Street
P.O. Box 24210
FORT LAUDERDALE, FL 33307
Tel: (305) 973-2600
CH,CS,E,M,P*

Hewlett-Packard Co.
4080 Woodcock Drive, Suite 132
JACKSONVILLE, FL 32207
Tel: (904) 398-0663
C*,CH*,M**

Hewlett-Packard Co.
6177 Lake Ellenor Drive
P.O. Box 13910
ORLANDO, FL 32859
Tel: (305) 859-2900
A,C,CH,CM,CS,E,P*

Hewlett-Packard Co.
4700 Bayoue Blvd.
Building 5
PENSACOLA, FL 32505
Tel: (904) 476-8422
A,C,CH,CM,CS,M

Hewlett-Packard Co.
5550 Idlewild, #150
P.O. Box 15200
TAMPA, FL 33684
Tel: (813) 884-3282
A*,C,CH,CS,E*,M*,P*

Georgia

Hewlett-Packard Co.
2000 South Park Place
P.O. Box 105005
ATLANTA, GA 30348
Tel: (404) 955-1500
Telex: 810-766-4890
A,C,CH,CM,CS,E,M,P*

Hawaii

Hewlett-Packard Co.
Kawaiahao Plaza, Suite 190
567 South King Street
HONOLULU, HI 96813
Tel: (808) 526-1555
A,CH,E,M

Illinois

Hewlett-Packard Co.
304 Eldorado Road
P.O. Box 1607
BLOOMINGTON, IL 61701
Tel: (309) 662-9411
CH,M**

Hewlett-Packard Co.
525 W. Monroe, #1300
CHICAGO, IL 60606
Tel: (312) 930-0010
CH,CS

Hewlett-Packard Co.
1200 Diehl
NAPERVILLE, IL 60566
Tel: (312) 357-8800
CH*,CS

Hewlett-Packard Co.
5201 Tollview Drive
ROLLING MEADOWS, IL 60008
Tel: (312) 255-9800
Telex: 910-687-1066
A,CH,CM,CS,E,M

Indiana

Hewlett-Packard Co.
11911 N. Meridian St.
CARMEL, IN 46032
Tel: (317) 844-4100
A,CH,CM,CS,E,M

Iowa

Hewlett-Packard Co.
4070 22nd Av. SW
CEDAR RAPIDS, IA 52404
Tel: (319) 390-4250
CH,CS,E,M



UNITED STATES (Cont'd)

Hewlett-Packard Co.
4201 Corporate Dr.
WEST DES MOINES, IA 50265
Tel: (515) 224-1435
A**,CH,M**

Kentucky

Hewlett-Packard Co.
10300 Linn Station Road, #100
LOUISVILLE, KY 40223
Tel: (502) 426-0100
A,CH,CS,M

Louisiana

Hewlett-Packard Co.
160 James Drive East
ST. ROSE, LA 70087
P.O. Box 1449
KENNER, LA 70063
Tel: (504) 467-4100
A,C,CH,E,M,P*

Maryland

Hewlett-Packard Co.
3701 Koppers Street
BALTIMORE, MD 21227
Tel: (301) 644-5800
Telex: 710-862-1943
A,CH,CM,CS,E,M

Hewlett-Packard Co.
2 Choke Cherry Road
ROCKVILLE, MD 20850
Tel: (301) 948-6370
A,CH,CM,CS,E,M

Massachusetts

Hewlett-Packard Co.
1775 Minuteman Road
ANDOVER, MA 01810
Tel: (617) 682-1500
A,C,CH,CS,CM,E,M,P*

Hewlett-Packard Co.
32 Hartwell Avenue
LEXINGTON, MA 02173
Tel: (617) 861-8960
CH,CS,E

Michigan

Hewlett-Packard Co.
4326 Cascade Road S.E.
GRAND RAPIDS, MI 49506
Tel: (616) 957-1970
CH,CS,M

Hewlett-Packard Co.
39550 Orchard Hill Place Drive
NOVI, MI 48050
Tel: (313) 349-9200
A,CH,CS,E,M

Hewlett-Packard Co.
1771 W. Big Beaver Road
TROY, MI 48084
Tel: (313) 643-6474
CH,CS

Minnesota

Hewlett-Packard Co.
2025 W. Larpentour Ave.
ST. PAUL, MN 55113
Tel: (612) 644-1100
A,CH,CM,CS,E,M

Missouri

Hewlett-Packard Co.
1001 E. 101st Terrace
KANSAS CITY, MO 64131
Tel: (816) 941-0411
A,CH,CM,CS,E,M

Hewlett-Packard Co.
13001 Hollenberg Drive
BRIDGETON, MO 63044
Tel: (314) 344-5100
A,CH,CS,E,M

Nebraska

Hewlett-Packard
10824 Old Mill Rd., Suite 3
OMAHA, NE 68154
Tel: (402) 334-1813
CM,M

New Jersey

Hewlett-Packard Co.
120 W. Century Road
PARAMUS, NJ 07652
Tel: (201) 265-5000
A,CH,CM,CS,E,M

Hewlett-Packard Co.
20 New England Av. West
PISCATAWAY, NJ 08854
Tel: (201) 981-1199
A,CH,CM,CS,E

New Mexico

Hewlett-Packard Co.
11300 Lomas Blvd.,N.E.
P.O. Box 11634
ALBUQUERQUE, NM 87112
Tel: (505) 292-1330
CH,CS,E,M

New York

Hewlett-Packard Co.
5 Computer Drive South
ALBANY, NY 12205
Tel: (518) 458-1550
A,CH,E,M

Hewlett-Packard Co.
9600 Main Street
P.O. Box AC
CLARENCE, NY 14031
Tel: (716) 759-8621
CH,CS,E

Hewlett-Packard Co.
200 Cross Keys Office Park
FAIRPORT, NY 14450
Tel: (716) 223-9950
A,CH,CM,CS,E,M

Hewlett-Packard Co.
7641 Henry Clay Blvd.
LIVERPOOL, NY 13088
Tel: (315) 451-1820
A,CH,CM,CS,E,M

Hewlett-Packard Co.
No. 1 Pennsylvania Plaza
55th Floor
34th Street & 8th Avenue
MANHATTAN NY 10119
Tel: (212) 971-0800
CH,CS,M*

Hewlett-Packard Co.
15 Myers Corner Rd.
WAPPINGER FALLS, NY 12590
CM,E

Hewlett-Packard Co.
250 Westchester Avenue
WHITE PLAINS, NY 10604
Tel: (914) 684-6100
CM,CH,CS,E

Hewlett-Packard Co.
3 Crossways Park West
WOODBURY, NY 11797
Tel: (516) 921-0300
A,CH,CM,CS,E,M

North Carolina

Hewlett-Packard Co.
305 Gregson Dr.
CARY, NC 27511
Tel: (919) 467-6600
C,CH,CM,CS,E,M,P*
Hewlett-Packard Co.
9600-H Southern Pine Blvd.
CHARLOTTE, NC 28210
Tel: (704) 527-8780
CH*,CS*

Hewlett-Packard Co.
5605 Roanne Way
P.O. Box 26500
GREENSBORO, NC 27420
Tel: (919) 852-1800
A,C,CH,CM,CS,E,M,P*

Ohio

Hewlett-Packard Co.
9920 Carver Road
CINCINNATI, OH 45242
Tel: (513) 891-9870
CH,CS,M

Hewlett-Packard Co.
16500 Sprague Road
CLEVELAND, OH 44130
Tel: (216) 243-7300
A,CH,CM,CS,E,M

Hewlett-Packard Co.
980 Springboro Pike
MIAMISBURG, OH 45343
Tel: (513) 859-8202
A,CH,CM,E*,M

Hewlett-Packard Co.
675 Brooksedge Blvd.
WESTERVILLE, OH 43081
Tel: (614) 436-1041
CH,CM,CS,E*

Oklahoma

Hewlett-Packard Co.
304 N. Meridian, Suite A
P.O. Box 75609
OKLAHOMA CITY, OK 73147
Tel: (405) 946-9499
C,CH,CS,E*,M

Hewlett-Packard Co.
3840 S. 103rd E. Ave., #100
P.O. Box 35747
TULSA, OK 74153
Tel: (918) 665-3300
A**,C,CH,CS,M*,E,P*

Oregon

Hewlett-Packard Co.
9255 S. W. Pioneer Court
P.O. Box 328
WILSONVILLE, OR 97070
Tel: (503) 682-8000
A,CH,CS,E*,M

Pennsylvania

Hewlett-Packard Co.
50 Dorchester Rd.
P.O. Box 6080
HARRISBURG, PA 17111
Tel: (717) 657-5900
C

Hewlett-Packard Co.
111 Zeta Drive
PITTSBURGH, PA 15238
Tel: (412) 782-0400
A,CH,CS,E,M

Hewlett-Packard Co.
2750 Monroe Boulevard
P.O. Box 713
VALLEY FORGE, PA 19482
Tel: (215) 666-9000
A,CH,CM,CS,E,M

South Carolina

Hewlett-Packard Co.
Brookside Park, Suite 122
1 Harbison Way
P.O. Box 21708
COLUMBIA, SC 29221
Tel: (803) 732-0400
A,C,CH,CS,M

Hewlett-Packard Co.
100 Executive Cntr. Dr.
Koger Executive Center
Chestertfield Bldg., Suite 124
GREENVILLE, SC 29615
Tel: (803) 297-4120
C

Tennessee

Hewlett-Packard Co.
One Energy Centr. #200
Pellissippi Pkwy.
P.O. Box 22490
KNOXVILLE, TN 37933
Tel: (615) 966-4747
A,C,CH,CS,M

Hewlett-Packard Co.
3070 Directors Row
MEMPHIS, TN 38131
Tel: (901) 346-8370
A,C,M

Hewlett-Packard Co.
220 Great Circle Road, Suite 116
NASHVILLE, TN 37228
Tel: (615) 255-1271
C,M,P*

Texas

Hewlett-Packard Co.
11002-B Metric Boulevard
AUSTIN, TX 78758
Tel: (512) 835-6771
C,CM,E,P*

Hewlett-Packard Co.
5700 Cromo Dr
P.O. Box 12903
EL PASO, TX 79913
Tel: (915) 833-4400
CH,E*,M**



SALES & SUPPORT OFFICES

Arranged alphabetically by country

UNITED STATES (Cont'd)

Hewlett-Packard Co.
3952 Sand Shell St
FORT WORTH, TX 76137
Tel: (817) 232-9500
A,C,CH,E,M

Hewlett-Packard Co.
10535 Harwin Drive
P.O. Box 42816
HOUSTON, TX 77042
Tel: (713) 776-6400
A,C,CH,CS,E,M,P*

Hewlett-Packard Co.
511 W. John W. Carpenter Fwy.
Royal Tech. Center #100
IRVINE, TX 75062
Tel: (214) 556-1950
C,CH,CS,E

Hewlett-Packard Co.
930 E. Campbell Rd.
P.O. Box 83/1270
RICHARDSON, TX 75083-1270
Tel: (214) 231-6101
A,CH,CM,CS,E,M,P*

Hewlett-Packard Co.
1020 Central Parkway South
P.O. Box 32993
SAN ANTONIO, TX 78232
Tel: (512) 494-9336
A,C,CH,CS,E,M,P*

Utah

Hewlett-Packard Co.
3530 W. 2100 South
P.O. Box 26626
SALT LAKE CITY, UT 84126
Tel: (801) 974-1700
A,CH,CS,E,M

Virginia

Hewlett-Packard Co.
4305 Cox Road
GLEN ALLEN, VA 23060
P.O. Box 9669
RICHMOND, VA 23228
Tel: (804) 747-7750
A,C,CH,CS,E,M,P*

Washington

Hewlett-Packard Co.
15815 S.E. 37th Street
BELLEVUE, WA 98006
Tel: (206) 643-4000
A,CH,CM,CS,E,M

Hewlett-Packard Co.
708 North Argonne Road
P.O. Box 3808
SPOKANE, WA 99220-3808
Tel: (509) 922-7000
CH,CS

West Virginia

Hewlett-Packard Co.
4604 MacCorkle Ave.
CHARLESTON, WV 25304
Tel: (304) 925-0492
A,M

Wisconsin

Hewlett-Packard Co.
275 N. Corporate Dr.
BROOKFIELD, WI 53005
Tel: (414) 784-8800
A,CH,CS,E*,M

URUGUAY

Pablo Ferrando S.A.C. e l.
Avenida Italia 2877
Casilla de Correo 370
MONTEVIDEO
Tel: 80-2586
Telex: Public Booth 901
A,CM,E,M

Mini Computadores, Ltda.
Avda. del Libertador Brig
Gral Lavalleja 2071
Local 007

MONTEVIDEO

Tel: 29-55-22
Telex: 901 P BOOTH UY
P

Olympia de Uruguay S.A.
Maquinas de Oficina
Avda. del Libertador 1997
Casilla de Correos 6644

MONTEVIDEO

Tel: 91-1809, 98.-3807
Telex: 6342 OROU UY
P

VENEZUELA

Hewlett-Packard de Venezuela C.A.
3RA Transversal Los Ruices Norte
Edificio Segre 1, 2 & 3
Apartado 50933
CARACAS 1071
Tel: 239-4133
Telex: 251046 HEWPACK
A,CH,CS,E,M,P

Hewlett-Packard de Venezuela C.A.
Residencias Tia Betty Local 1
Avenida 3 y con calfe 75
MARACAIBO, Estado Zulia
Apartado 2646
Tel: (061) 75801-75805-75806-80304
Telex: 62464 HPMAR
C,E*

Hewlett-Packard de Venezuela C.A.
Urb. Lomas de Este
Torre Trebol — Piso 11
VALENCIA, Estado Carabobo
Apartado 3347
Tel: (041) 222992/223024
CH,CS,P

Albis Venezolana S.R.L.
Av. Las Marias, Ota. Alix,
El Pedregal
Apartado 81025
CARACAS 1080A
Tel: 747984, 742146
Telex: 24009 ALBIS VC
A

Tecnologica Medica del Caribe, C.A.
Multicentro Empresarial del Este
Ave. Libertador
Edif. Libertador
Nucleo "C" - Oficina 51-52
CARACAS
Tel: 339867/333780
M

CIZUCA

Cientifica Zulia C.A.
Calle 70, Los Olivos
No. 66-86
Apartado 1843
MARACAIBO
Tel: 54-64-37, 54-63-85, 54-64-94
Telex: 62144
A

YUGOSLAVIA

Do Hermes
General Zdanova 4
Telex: YU-11000 BEOGRAD
A,CH,E,P
Hermes
Titova 50
Telex: YU-61000 LJUBLJANA
CH,CS,E,M,P
Elektrotehna
Titova 51
Telex: YU-61000 LJUBLJANA
CM

ZAMBIA

R.J. Tilbury (Zambia) Ltd.
P.O. Box 32792
LUSAKA
Tel: 215590
Telex: 40128
E

ZIMBABWE

Field Technical Sales
45 Kelvin Road, North
P.B. 3458
SALISBURY
Tel: 705 231
Telex: 4-122 RH
E,P
August 1984

HP distributors are printed in italics.

